



LM SERIES OWNERS MANUAL

Single Sided Models:

507-6LM
607-6LM
507-9LM
607-9LM

Double Sided Models:

1007-6LM
1207-6LM
1007-9LM
1207-9LM

How to most benefit athletes, coaches, officials and spectators from the  when used for distance runs, track and swimming events, game period timing or for training routines used by track, swimming, football, physical fitness, and many other sports.

MANUAL NO. 500-193 Rev. 8

November 2007

1-800-854-8530



ELECTRO-NUMERICS, INC.

42213 Sarah Way, Temecula CA 92590

Web Site: www.Raceclock.com

Email: sales@ElectroNumerics.com

TABLE OF CONTENTS

SECTION	PAGE
1.0 INTRODUCTION	3
2.0 GENERAL DESCRIPTION	3
2.1 INTERNAL POWER SYSTEM	3
2.2 ACCESSORIES	4
2.2.1 RC100-X Remote Control Unit	4
2.2.2 RK100-X Remote Keyboard Unit	4
2.2.3 Remote Start Options	4
2.2.4 Tripod Stand TS02	6
2.2.5 Carrying Cases	6
2.3 SYSTEM CONTROLS	6
2.4 SUMMARY OF FUNCTIONS AND MODES FOR VARIOUS SPORTS	7
2.4.1 Road Races and Distance Runs	7
2.4.2 Track Events	8
2.4.3 Swim Meet Events	8
2.4.4 Track Training Routines with Recall of Interim Times	8
2.4.5 Training Application for Football, Swimming, and Physical Fitness	8
2.4.6 Game Period Clock	8
2.4.7 Time-of-Day	8
3.0 OPERATION PROCEDURES FOR VARIOUS SPORTS	8
3.1 DISTANCE AND CROSS COUNTRY RACES	8
3.1.1 Race Timing at the Finish Line	9
3.1.2 Place Count at the Finish Line	10
3.1.3 Start Time Countdown	10
3.1.4 On-Course Clock Location	10
3.2 TRACK MEETS	13
3.2.1 Coordination with Meet Announcer	13
3.2.2 Coordination with Meet Director	13

TABLE OF CONTENTS (Cont.)

SECTION	PAGE
3.2.3	Setup of System Components 14
3.2.4	Timing of Lead Runner and Interim Splits 14
3.2.5	Timing of Several Runners 15
3.2.6	Manual Entry of Corrected or Official Times 16
3.3	SWIM MEETS 16
3.4	GAME PERIOD CLOCK 16
3.5	TIME-OF-DAY 17
3.6	PROCEDURES FOR ATHLETE TRAINING ROUTINES 17
3.6.1	Description of the Three Split Timing Modes 18
3.6.1.1	Cumulative Lap Split 18
3.6.1.2	Taylor Lap Split 18
3.6.1.3	Frame Split 18
3.6.2	Typical Track Training Routines 19
3.6.2.1	Unattended Pace Clock 19
3.6.2.2	Timing Separated Intervals 19
3.6.2.3	Timing Consecutive Intervals , Taylor Lap 20
3.6.2.4	Hurdler "Foot Plant" Interval Timing 21
3.6.3	Training Applications for Swimming 21
3.6.4	Training Applications for Football 21
3.6.5	Physical Fitness Training 22
4.0	REMOTE DISPLAY, RDOPTION OPERATION INSTRUCTIONS 22
4.1	RD Option when used with Finish Lynx 25
5.0	TRIPOD STAND, TS02 SETUP INSTRUCTIONS 26
6.0	USING YOUR CLOCK IN INCLEMENT WEATHER 26
7.0	SERVICE AND WARRANTY 27

1.0 INTRODUCTION

Congratulations! You are the owner/operator of the best portable large-digit sports timing system available today. The RACECLOCK by Electro-Numerics will provide many years of reliable service and complete capability for most sports timing requirements. This manual describes the system operating procedures for various sports, the operating instructions for each timing mode, the accessories, and provides battery maintenance instructions, service and warranty information.

A wide range of sports events and training activities can benefit from the many functions of the RACECLOCK, which are described in this manual. If you have any questions or need assistance with your RACECLOCK, contact Electro-Numerics Customer Service.

Tel: 800-854-8530 (U.S.A.) or 951-699-2437

Email: sales@electronumerics.com, Fax: 951-695-7246.

2.0 GENERAL DESCRIPTION

The RACECLOCK is self-contained and operates from an internal rechargeable battery which is automatically maintained at optimum charge whenever the RACECLOCK is left plugged into an AC outlet. With a fully charged battery, the clock will operate up to 24 hours continuously, depending on the model. The RACECLOCK is housed in a rugged, weather-resistant, tamper-proof case, for a lifetime of reliable service. These clocks are not designed to be "rainproof" and must be covered with a clear poly bag or other means of protection during inclement weather, see Section 6.0.

Controls necessary to operate the RACECLOCK are located on the case. Optional hand-held controls with 25 to 50 foot cables provide remote capabilities and convenience. A tripod stand is available and may be adjusted up to seven feet allowing easy viewing by athletes and spectators. Carrying cases are available which provides protection while storing or transporting the RACECLOCK. See ACCESSORIES, paragraph 2.2.

2.1 INTERNAL POWER SYSTEM

The RACECLOCK is powered from its own internal rechargeable battery. Depending on the model and mode of operation, the RACECLOCK will operate continuously with a fully charged battery up to 24 hours. If the clock is plugged into AC power while operating, the run time will be extended.

Charging power is 115Vac, 60 Hz. To recharge the battery, simply plug the power cord stored underneath the case into an AC receptacle for 24 hours.

The LED charge indicator on the side of the clock will indicate a charging condition. The indicator will blink rapidly with a low battery and blink slowly indicating a full charge.

The RACECLOCK batteries will charge with the power switch in either the ON or OFF position. A properly maintained battery has a projected life of several years. The battery should be placed on charge for 24 hours after each usage. The battery may be left on charge for extended periods when not in use, so it will always be ready for that unexpected need. Note that the design of the electronics in the clock prevents overcharging. If the RACECLOCK is put into storage, the battery should be recharged every three months.

2.2 ACCESSORIES

2.2.1 RC100-X Remote Control Unit (Figure 1)

This Remote Control provides the four RACECLOCK controls (SELECT MODE, COUNT DOWN/STOP, COUNT UP/SPLIT and CLEAR) in a easy-to-use hand held box with large push-button controls. The standard cable is 25' with lengths up to 50' available. Operation of these controls is the same as described in section 2.3 (System Controls).

2.2.2 RK100-X Remote Keyboard Unit (Figure 2)

This Remote Keyboard provides all the keyboard functions available on the side of the clock allowing remote operation and programming. The standard cable is 25' with lengths up to 50' available.

2.2.3 Remote Start Options

The RACECLOCK may be started from a remote device such as a printing timer, gun start sensor or photo sensor.

CA44-25 is used with the Time Machine printing timer to start the clock with at the same time as the printing timer. Cable CA35-25 may be connected to any set of normally open dry isolated contacts for remote start/stop control. Push-button accessory PB600-25 is used to start and take splits in the "C" mode and may be used for repetitive timing in the "F" mode. CA45-50 is used to connect the RACECLOCK to a Finish Lynx timing system, see section 4.0.



Figure 1



Figure 2



Figure 3
(Tripod Stand)



Figure 4
(Carrying Case)

2.2.4 Tripod Stand TS02 (Figure 3)

This stand provides sturdy support and allow the clock to be raised to seven feet for easy viewing. See paragraph 5.0 for proper use of these stands.

2.2.5 Carrying Cases (Figure 4)

Heavy duty cases are available for all RACECLOCK models. These cases provide maximum protection to the clock when transporting or storing.

2.3 SYSTEM CONTROLS

All controls are located on the end of the RACECLOCK and consist of a power ON/OFF switch and a function/numeric keyboard. Remote control can also be provided by using accessories: RC100-X Remote Control, RK100-X Remote Keyboard or cable accessories PB600-25, CA34-25 or CA44-25. See Section 2.2.3. The power switch turns on the RACECLOCK in the "C" Mode. The keyboard and/or Remote Control units are then used as described in the section of this manual for each type of sport.

When the cord on the bottom of the RACECLOCK is plugged into an AC power outlet, an LED charge indicator above the keyboard lights. This LED operates with the power switch in either the On or OFF positions whenever the clock is plugged, in indicating that the battery is being charged. See Section 2.1 for LED charge indicator operation.

In Summary, the functions of the keyboard are:

KEY	FUNCTION
"C" CLEAR	Clears the time count, display and the recall memory back to zero times. Does not effect the time-of-day mode.
"M" MODE SELECT	Sequentially selects any one of the seven modes of operation ("C", "L", "F", "PA", "PJ", "E", "PL") when in CLEAR.
COUNT UP/SPLIT	<ol style="list-style-type: none">1. Starts count up and enters split holds.2. Recalls splits after STOP.3. Increments place count in "PL" mode.

KEY	FUNCTION
COUNT DOWN/STOP	<ol style="list-style-type: none"> 1. Stops Count UP 2. Alternately starts and stops Count Down from a preset time.
"1/100"	<p>Alternately selects:</p> <ol style="list-style-type: none"> 1. Hours-minutes-seconds or minutes-seconds-1/100 seconds format in "C", "L" or "F" modes. 2. Hours-minutes or hours-minutes-seconds in "T" time-of-day mode.
"T"	<ol style="list-style-type: none"> 1. Enters a preset time-of-day. 2. Recall time-of-day.
"0" to "9"	Used to enter preset times, factors and place counts.

For a complete description of control usage, see OPERATION PROCEDURES FOR VARIOUS SPORTS, section 3.0.

2.4 SUMMARY OF FUNCTIONS AND MODES FOR VARIOUS SPORTS

The RACECLOCK performs many different functions, which may use any one of the seven timing modes. These modes are selected by actuating the MODE SELECT key, after turning ON the power switch or CLEAR. The selected mode is indicated by its symbol at the left of the display ("C", "L", "F", "PA", "PJ", "E", "PL"). Select modes "Ch", "Lh", "Fh" by pressing the "1/100" key.

Use the following summary of RACECLOCK functions and their modes of operation as an index to the detailed instructions set forth in the OPERATION PROCEDURES FOR VARIOUS SPORTS, section 3.0.

2.4.1 Road Races and Distance Runs

- A. Finish line clock for race time (with or without time preset). Use "C" cumulative split mode. See section 3.1.1.
- B. On-Course clock to display race time and/or pace per mile or kilometer and/or projected finish time. Use "PA", "PJ" and "E" modes. See section 3.1.4.
- C. Place Count scoreboard. Use "PL" mode. See section 3.1.2.
- D. Start time count down. See section 3.1.3.

2.4.2 Track Events

Race time, cumulative lap splits with recall. Use "Ch" cumulative 1/100 seconds mode. See paragraph 3.2 for details of operation.

2.4.3 Swim Meet Events

Race time, cumulative lap splits with finish or lap time recall. Use "Ch" cumulative 1/100 seconds mode. See paragraph 3.3 for details of operation.

2.2.4 Track Training Routines, with recall of interim times

Relay leg-times, interval times for 200 meter pacing or times between a hurdler's foot plants, track pace clock, etc. Use "Lh" Taylor Lap Split or "Fh" frame lap split 1/100 seconds modes. See paragraph 3.6.2 for details of operation.

2.4.5 Training application for swimming, football and physical fitness.

Use various modes. See paragraphs 3.6.3, 3.6.4 & 3.6.5 for details of operation.

2.4.6 Game Period Clock

Use "C" cumulative count down mode. See paragraph 3.4 for details of operation.

2.4.7 Time-of-Day

Use hours-minutes or minutes-seconds mode. See paragraph 3.5 for details of operation.

3.0 OPERATION PROCEDURES FOR VARIOUS SPORTS

Set forth in this section are some of the RACECLOCK procedures now being used by race and meet directors and their timers, and by coaches, trainers and athletes. However, these procedures can be modified easily to special situations and needs because of the flexibility of the RACECLOCK functions and modes.

3.1 DISTANCE AND CROSS COUNTRY RACES (Events normally timed in hours minutes and seconds)

RACECLOCKS are used every week at hundreds of distance runs, to display race times to runners at the finish line. Often, other RACECLOCKS are used along the race course to display to runners their pace and/or projected finish time, as well as their interim race times and place counts.

The usual procedure is for the RACECLOCK coordinator to be at the start line with a stopwatch, which he starts at the starting gun. He then travels by car ahead of the runners to the RACECLOCKS at each on-course and/or finish line location and synchronizes each of the clocks to his stopwatch as described below.

3.1.1 Race Timing at the Finish Line

Clear to "C" mode, then:

- 1) The RACECLOCK can now be started with the starting gun or,
- 2) If the RACECLOCK is to be synchronized to an on-going race time, enter that time in hours-minutes-seconds with the keyboard.

Example: If the RACECLOCK coordinator arrives at the finish line by car from the start line with a race time of 40 minutes and 30 seconds, enter from the keyboard 41 minutes (4100) as the synchronizing race time. The display should read 41.00.

Press COUNT UP at the preset synchronizing time.

Press SPLIT to hold split times, such as the winning time for each class of runner. Time will automatically resume after each SPLIT entry with the correct elapsed time.

Press STOP to stop time.

Press SPLIT to recall up to eleven split times plus the final stop time. Dashes will indicate end of recall. (If more than eleven split times are entered, the first ten and the last split time, plus the final stop time will be recalled).

Press 1/100, then SPLIT will recall the split times in minutes, seconds, and 1/100 seconds.

Press 1/100 again and split time recall will return to hours, minutes and seconds.

Press CLEAR to reset (if in "Ch" mode, also press "1/100").

3.1.2 Place Count at the Finish Line

Select "PL" mode. For a clearer display, cover the colons with black tape. Press COUNT UP. The display will increment up by one count. Press COUNT DOWN and the display will increment down by one count. Maximum count is 9999.

To correct or preset a count, press COUNT UP or COUNT DOWN sequentially. For greater convenience, use the hand-held remote control RC100-X, remote keyboard RK100-X or remote push-button PB600-25 to enter place counts.

3.1.3 Start Time Count-Down

If the RACECLOCK is located at or near the start of the race, it can be used for time-of-day or to count down time remaining before the start of the race. See paragraph 3.4 for these modes.

3.1.4 On-Course Clock Location

RACECLOCKS are often used along the race course to display race times, pace, projected finish times, or place counts. Such on-course displays are ideally suited for marathons and other distance events.

The RACECLOCK can be operated to display any one mode continually or a combination of two or more modes selectively, in sequence. For example, the pace mode is usually more important to runners earlier on the course, and projected finish time is of greater interest towards the end of the course. Often, two RACECLOCKS are at one location, such as the halfway point of a marathon, to display race time and pace concurrently. Or, a single RACECLOCK can be operated to display race time and pace and/or projected finish time alternately.

It is possible to display place count alternately with race time, pace, and/or projected finish time, although it is easier for runners if two clocks are used (one to display place count continually and the other to sequentially display race time and pace or projected finish). If place count is to be displayed continually rather than alternately with race time, it is easier to use the PLACE COUNT procedure as described above, rather than the multiple mode procedure described, following.

To Operate the RACECLOCK in any one or a combination of these modes, "CLEAR" the RACECLOCK.

Using the MODE key, select "PA" to enter the Pace Factor.

$$\text{Pace Factor} = \frac{1}{\text{Clock location on course in miles or Kilometers}}$$

Example: 10K race (6.2 miles), clock located at 3 miles.

$$\text{Pace Factor} = 1/3 = 0.333$$

Enter 333 and display will read P:A3.33. Always enter three digits to the right of the decimal, even if the first and/or last digit is zero. Pace can only be used for mile markers greater than 1 mile, i.e. 2, 5, 10 mile etc.

If pace is not wanted, enter 000 to deactivate the pace mode.

Using the MODE key, select "PJ" to enter the Projected Finish Factor.

$$\text{Projected Finish Factor} = \frac{\text{Length of Race}}{\text{Clock location on course in miles or Kilometers}}$$

Example: 10K race (6.2 miles), clock located at 3 miles.

$$\text{Projected Finish Factor} = 6.2 / 3 = 2.07$$

Enter 207 and display should read P:J2.07. Always enter one digit to the left and two digits to the right of the decimal, even if the first and/or last digits are zero.

If projected finish time is not wanted, enter 000 to deactivate the projected finish mode.

Using the MODE key, select "E" to enter Elapsed Race Time.

- 1) If the RACECLOCK is to be started with the starting gun, press COUNT UP and the display will blank, indicating zero elapsed time present or,
- 2) If the RACECLOCK is to be synchronized on-course to an elapsed time, enter that time in hours, minutes and seconds. Then press COUNT UP to load the preset. The display will blank for one to several seconds, then will display the preset elapsed time.

Example: If the RACECLOCK coordinator arrives at the RACECLOCK location by car from the start line at an elapsed time of 20 minutes and 30 seconds, enter 21 minutes (2100) as the "synchronizing elapsed time". The display should read :21.00.

Press COUNT UP a second time at:

- 1) The starting gun or,
- 2) The synchronizing elapsed time, if a time is preset. The RACECLOCK will start counting race time.

Press SPLIT sequentially to enter place counts, if that mode is being used. (The RACECLOCK must be in the "C" mode).

Press MODE to display pace. If 000 factor was entered, the display will blank.

Press MODE again to display projected finish time. If 000 factor was entered, the display will blank.

Press MODE for the third time to display place count. If no place counts have been entered, display will blank.

If you continue to actuate the MODE key, the display will sequentially display on-going race time, pace, projected finish, place count and back to race time etc.

If a mode has been deactivated by entering 000 as the factor for that mode, the display will blank when that mode is selected. Of course, the RACECLOCK can be left in any one mode continuously.

Place counts may be entered in any mode but are displayed only in the place count mode.

For greater convenience, use hand-held remote control RC100-X if modes are to be sequenced or place counts entered or you can use push-button PB600-25 if only place counts or splits are to be entered.

3.2 TRACK MEETS

RACECLOCKS are used at track meets to provide spectators, contestants and officials an on-going real-time display of the progress and results of each event. If a photo-finish camera and/or backup stopwatch provides alternate or official time results, the RACECLOCK provides an instant preliminary readout of winning time. The official result then may be entered from the keyboard.

With the RD, Remote Display option installed, and with the RACECLOCK connected to a primary timing computer such as the Finish Lynx photo-finish camera, the RACECLOCK becomes the primary display of finish times adding excitement and interest for the spectators and contestants.

3.2.1 Coordination With Meet Announcer

Spectator benefits are greatly enhanced if the public address announcer keys spectator attention to the RACECLOCK. Before an event, the operator and announcer should discuss how to best coordinate commentary by the announcer with the operation of the RACECLOCK.

For example, during the mile run, the operator can display quarter-mile splits, which would be noted by the announcer and compared to previous meet record interim splits, compared to previous meet record interim splits, especially if a new record seems likely.

After each event, the operator can recall interim splits or individual split times as the announcer recaps the race. Then, when the official time from the photo-finish camera is available, the operator can enter it at the keyboard as it is announced and commented on by the announcer.

3.2.2 Coordination With Meet Director

Each meet, arena and stadium is different, and it is important before the event to coordinate with the Meet Director on the location of the RACECLOCK and the operator's platform. If possible, locate the RACECLOCK directly in line with the finish line and as close as possible. The RACECLOCK and platform should be located so as to provide good visibility for both the operator and spectators but not so as to conflict with other events and the functions of the official timers.

Often, the RACECLOCK is operated in the time-of-day mode between events to assist the Meet Director, coaches and athletes with time schedules. Once the time is set, it can be recalled instantly without having to be reset.

3.2.3 Setup of System Components

Six inch models 507-6LM, 607-6LM, 1007-6LM or 1207-6LM, readable at 240 feet, provide adequate visibility for smaller track facilities. Stadiums and larger indoor arenas require the larger digit, nine inch models 507-9LM, 607-9LM, 1007-9LM or 1207-9LM readable at 360 feet.

The RACECLOCK is best supported on the tripod stand TS02. If the stand is left at the non-extended height of six feet, the RACECLOCK can be swiveled to display results to both ends of the grandstand. The two-sided, nine inch models 1007-9LM and 1207-9LM RACECLOCKS provide visibility on both sides of the field and are ideal for stadiums and large arenas.

The RACECLOCK and operator should be on a one to two foot high platform, so the operator can see the entire track with a clear view of the various start lines, split distances, and the finish line.

A hand-held remote control RC100-X is recommended for track timing, to allow mobility for the operator. Also, the large, snap-action push-button improve operator accuracy, compared to the keyboard.

3.2.4 Timing of the Lead Runner and Interim Splits

This procedure displays and permits recalling of up to eleven interim splits and the winning time for the lead runner only.

Select "Ch" mode. This selects the 1/100 second cumulative split mode.

Press COUNT UP at the race start, by reacting to the smoke of the starting gun or the RACECLOCK may be directly connected to a gun start sensor, printing timer or other start device using accessory cables CA34-25 or CA35-25. The RACECLOCK will now begin timing and display race time in seconds.

Press SPLIT as the lead runner completes interim splits, such as 200 meters out of 400 meters, etc. The RACECLOCK will freeze the split time to 1/100 seconds for three seconds, then resume display of race time. Any number of splits can be displayed.

Press STOP as the lead runner finishes. The display will then stop at the winning time to 1/100 seconds. This procedure stops the RACECLOCK at the first finish time and timing does not continue, even though the race is not over for all runners.

Press SPLIT to recall each of the interim split times to 1/100 seconds. Each actuation of the SPLIT recalls the next split, in sequence through eleven splits. After these eleven splits have been recalled, the finish time is displayed. Another SPLIT actuation displays dashes and subsequent actuations repeat the recall sequence. Dashes will indicate the end of recall. If more than eleven split times are entered, the first ten and the last split time plus the final stop time will be recalled.

Press CLEAR to reset the time display and reset the memories back to zero times for the next event. Display will show "Ch".

Press "T" momentarily to return to time-of-day, if previously set.

3.2.5 Timing of Several Runners

This procedure keeps the RACECLOCK operating until the last runner finishes and, if runners are separated by one-half second or more, permits display of each finish time and the recalling of up to twelve finish times. Interim splits are not practical.

Select "Ch" mode and press COUNT UP at the smoke of the starting gun or the RACECLOCK may be directly connected to a gun start sensor, printing timer or other start device using accessory cables CA34-25 or CA35-25. The RACECLOCK will now begin timing and display race time in seconds.

Press SPLIT as the winner finishes. The RACECLOCK will display winning time to 1/100 seconds for three seconds or until the SPLIT key is again pressed showing the finish time of the next runner.

Press STOP for the last finisher. The display will show last place time to 1/100 seconds.

Press SPLIT to recall winning time in 1/100 seconds. Each actuation of SPLIT recalls the next finish through the first ten, then the final finish time is displayed. Another SPLIT actuation displays dashes and subsequent actuations repeat the recall sequence of race results. If more than eleven split times are entered, the first ten and the last split time plus the final stop time will be recalled.

Press CLEAR to reset the time display and reset the memories back to zero times for the next event. Display will read "Ch".

Press "T" momentarily to return to time-of-day, if previously set.

3.2.6 Manual Entry of Corrected or Official Times

Times from official stopwatches or a photo-finish camera can be displayed by using the keyboard.

Select "C" mode, if in "Ch". Press CLEAR to clear the display. Use the keyboard to enter the official result. For example, to enter 4:05:01, enter 40501 in sequence.

Press CLEAR to return to timing mode. Press "Ch" to enter the 1/100 seconds timing mode for the next event.

3.3 SWIM MEETS

The RACECLOCK is used along with the official hand-held stopwatch or all-electronic touch-pad printing timer system, so that spectators can follow in real time the progress of the event. The RACECLOCK is usually used to display interim lap times and the winning time. Use the "Ch" mode and the procedure described for the Timing of Lead Runner and Interim Splits, in paragraph 3.2.4.

3.4 GAME PERIOD CLOCK (COUNT DOWN MODE)

The RACECLOCK is a conveniently portable game period clock for events where a main scoreboard is not available. The remote control RC100-X should be used to provide more convenient and accurate operation than is possible on the keyboard.

Select "C" mode. See paragraph 2.3. Enter the period time in minutes and seconds. For example, entering 1500 will display 15.00 (a 15 minute period). Press COUNT DOWN/(stop) at the start of the period.

Press (count down)/STOP to stop the clock for a time-out.

Press COUNT DOWN/(stop) to restart the timing (time-in).

Press CLEAR to reset the clock. Reenter the period time before the start of the next period.

3.5 TIME-OF-DAY

The RACECLOCK can be set to operate as a 12 hour clock. Once set, it will internally maintain the time-of day, even if operated in other modes. It does not need resetting when returned to the time-of-day mode. This feature facilitates off and on use as a time-of-day clock in a gymnasium or before an event. It can be switched to the countdown mode for game periods or to other modes for event timing and then returned to the time-of-day mode.

Press CLEAR. Enter time-of-day in hours and minutes via the keyboard.

Example: At 7:52AM, enter 752; at 10:45AM, enter 1045 etc.

Press T for two seconds at the instant of the preset time, until the display clears and re-displays the time-of-day counting in seconds.

Press 1/100 to display the time in hours and minutes.

Note: Five digit Raceclock models show the time of day in hours, minutes & seconds (Hrs:Min.Sec), times above 9 hours (9 o'clock) will not be shown. Push the 1/100 button to display in hours & minutes (Hrs-Min) for a full 12 hour display. The dash between the Hrs & Min indicates the time-of-day mode. Six digit models will display time-of-day to 12Hrs:59Min.59Sec or Hrs. & Min. (12Hrs-59Min).

3.6 PROCEDURES FOR ATHLETE TRAINING ROUTINES

The RACECLOCK is a valuable tool for many sports disciplines. The large display can be read from any location in a gymnasium or an outdoor track eliminating the need to call

times from a stopwatch or printer. The portability and freedom from an external power connection makes daily setup and usage very easy and practical.

This section describes typical training routines for various sports. The flexibility of the RACECLOCK permits it to be adapted to many needs.

3.6.1 Description of the three Split Timing Modes

Many training routines performed by the RACECLOCK are based on a series of timed intervals, often referred to as "splits". The RACECLOCK operates in any of three different split modes and will display an unlimited number of these splits and then recall the last 11 plus the stop time, for review and recording. To gain a better understanding of these functions, it is recommended they be tried out on the RACECLOCK as described below.

3.6.1.1 Cumulative Lap Split, "C" or "Ch" Modes

This mode is used to display and recall interim cumulative times. After COUNT UP/START, each SPLIT actuation holds the cumulative split display for three seconds while the time count continues internally, then the counting display resumes.

3.6.1.2 Taylor Lap Split, "L" or "Lh" Modes

This mode is used to display and recall the time which has elapsed between splits, such as individual consecutive lap times. After COUNT UP/SPLIT each SPLIT actuation holds the lap split for three seconds while the time count continues internally restarting from zero, then the counting display resumes. Use COUNT DOWN/STOP to enter the last split.

3.6.1.3 Frame Split, "F" or "Fh" Modes

This mode is used to display and recall separated intervals out of an ongoing routine or a series of events such as 200 meters out of each 400 meter lap. The first COUNT UP/SPLIT actuation starts the time count. The next SPLIT actuation stops it and holds the display until a subsequent SPLIT actuation resets the time to zero and repeats the sequence. Use COUNT DOWN/STOP to enter the last split.

For these modes of operation, the hand-held remote control RC100-X or push-button PB600-25 is recommended to provide better operator accuracy and convenience, as compared to the keyboard.

3.6.2 Typical Track Training Routines

The use of the RACECLOCK for interval timing and other training routines frees the coach from calling out times from a stopwatch. The coach can better observe the running style, give verbal comments and encouragement, and work with more than one athlete at a time. For the athlete, his training adjustments are enhanced by being able to observe the ongoing time, as he rounds a turn into the finish of an interval lap.

3.6.2.1 Unattended Pace Clock

Place the RACECLOCK just beyond the track finish line or any location that is visibly marked, so that the runner can see the display as he completes each lap.

Select the "C" mode. Press COUNT UP. The RACECLOCK will count up in seconds and the runner will see the cumulative time from the start of the sequence.

3.6.2.2 Timing Separated Intervals, Frame Split

Place the RACECLOCK so that the coach/operator can see the start and finish of, for example, a 100 meter interval and the runner can see the RACECLOCK immediately after finishing the interval.

Select "Fh" mode. Press COUNT UP as the runner enters the interval. The display will count up in seconds.

Press SPLIT again as the runner completes the interval. The RACECLOCK will display the interval time to 1/100 seconds, as the runner continues his laps.

Press COUNT UP as the runner reenters the interval on the next lap. The display will instantly clear the last interval time and count up from zero.

Press SPLIT as the next interval is completed. Any number of intervals can be timed and displayed by this method. Press STOP, when the final interval is completed.

Press SPLIT to recall each interval time in sequence for analysis. Up to eleven interim plus the final interval can be recalled. After all intervals have been recalled, the next SPLIT actuation displays all dashes. Subsequent actuations repeat the recall sequence.

Press CLEAR to reset the time display and reset the memory back to zero.

3.6.2.3 Timing Consecutive Intervals, Taylor Lap

If consecutive 200 meter intervals on a 400 meter track or consecutive laps are to be timed, operation is the same as for Separated Intervals (paragraph 3.6.2.2) except the Taylor Lap is used.

Select "Lh" Taylor Lap mode with the mode select and 1/100 keys.

Press COUNT UP as the runner begins the interval or lap. The display will count up in increments of seconds.

Press SPLIT as the first interval or lap is completed and the next begins. The RACECLOCK will display the interval time, while internally restarting from zero timing for the next interval. After three seconds, the display will resume count up in increments of seconds.

Press SPLIT to record and display the next interval. Any number of intervals can be timed and displayed.

Press STOP when the last interval is completed. Recall of the splits is by the same procedure as Frame (Separated Interval) Splits, (paragraph 3.6.2.2)

intervals, including the final stop interval, can be recalled for analysis by actuating SPLIT after STOP.

3.6.2.4 Hurdler "Foot Plant" Interval Timing

The time between foot plants after clearing each hurdle can be recorded and recalled by using the "Ch" cumulative split mode. Usually, the coach starts timing at the start signal, then actuates SPLIT at each foot plant and stops timing after the final hurdle or at the end of the run. Up to twelve intervals, including the final stop interval, can be recalled for analysis by actuating SPLIT after STOP.

3.6.3 Training Applications for Swimming

The RACECLOCK is self-powered and operates up to twenty four hours without recharging. Therefore, the shock hazard that might result from a pool-side extension cord is eliminated.

Many swimming routines are similar to those for track. For example, as a pool lap clock, use the Unattended Pace Clock procedure (paragraph 3.6.2.1), with the RACECLOCK located at the end or the side of the pool.

Individual lengths can be timed to 1/100 seconds by using the Timing of Separated Intervals procedure (paragraph 6.6.2.3). The Separated Interval procedure is also suited for timing swim turns.

3.6.4 Training Applications for Football

RACECLOCKS are used to time 40 yard movement times. Use the Separated Intervals procedure (paragraph 3.6.2.2). The instant display saves time when a number of athletes are involved because the trainer/coach need not call out times and reset the stopwatch for each movement time since the Frame Split mode automatically resets after each timing interval.

The RACECLOCK is also used to train timing for pass receiver patterns and pass release routines. Use the Hurdler Foot Plant procedure (paragraph 6.6.2.4).

Position the RACECLOCK down-field beyond the field of action/play, facing up field. The quarterback and receiver should then see the time count which is started by the coach when the ball is snapped. Three or more intervals can be timed on a single play and recalled for analysis, e.g., pass release time, receiver cut time, and reception time.

3.6.5 Physical Fitness Training

Use the COUNT DOWN mode to time an exercise class. Preset the length of the period and start the countdown at the beginning of the class. The RACECLOCK will stop when the period has ended.

In a workout room, use the RACECLOCK as a digital seconds counter. Several athletes performing separate exercise routines can time their series of exercise sequences. Sometimes, the RACECLOCK is synchronized to the time-of-day in minutes, so that it displays the minutes of the hour as well as counting in seconds. Use the Unattended Pace Clock procedure (paragraph 3.6.2.1)

4.0 REMOTE DISPLAY, RD OPTION OPERATING INSTRUCTIONS

DESCRIPTION

This option allows the clock to be operated in either standard RACECLOCK or Remote Display mode. With the selector switch in the RACECLOCK position, the display will operate as described in the previous sections of this manual. With the selector switch in the RD position, the display operates as a serial RS-232 input Remote Display receiving information from another timing device such as a computer or Finish Lynx timing system. To use the remote display option, it is first necessary to connect a signal cable to a computer or other device capable of transmitting serial data in the correct format. See CONNECTIONS TO A PERSONAL OR IBM COMPATIBLE COMPUTER later in this text. When changing from RD or RACECLOCK mode, it is first necessary to turn off the power switch located on the side of the clock. Once the switch position is changed and the power switch is turned on, the new mode will take effect.

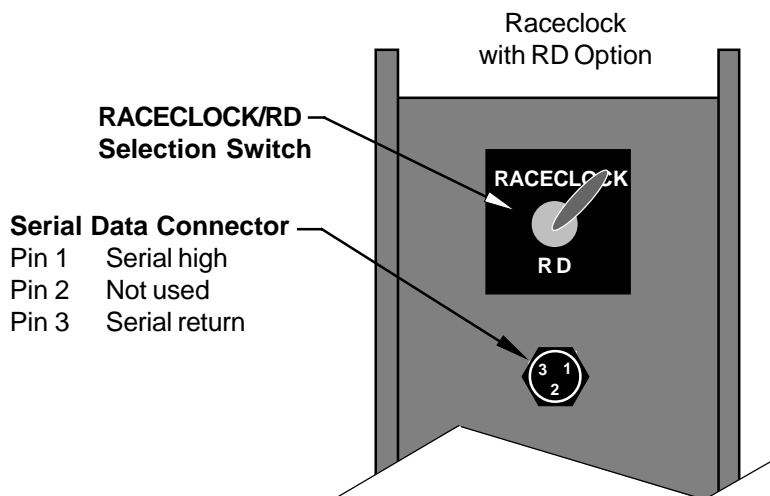

Note that the position of this switch and serial connector will vary from model to model.

The serial data transmitted, must be compatible with the Remote Display and transmitted in the following format. The signal containing this format may be in the form of serial ASCII (RS232) data. The data format that the Remote Display will accept is:

#	POLARITY	D	D	D	D	D	D	CR
----------	-----------------	----------	----------	----------	----------	----------	----------	-----------

# (Pound sign)	Decimal 35
Polarity: +	Decimal 43
-	Decimal 45
space	Decimal 32
D (Data - Six digits numbers 0 to 9)	Decimal 48 to 57
CR (Carriage return)	Decimal 13

The Baud rate must be 1200			
The data stream contains:			
1 Start bit	8 Data bits	Parity: Even	1 Stop bit

For example, if the number to be displayed is -17592, the data stream would be assembled in the following manner.

#	POLARITY	D	D	D	D	D	CR	
Decimal code	35	45	49	55	53	57	50	13

ERROR CODES

If some of the previous parameters are not correct, error codes will appear on the display in the form of ErXX, where XX is a one or two digit code defining the type of error. When more than one error is present the codes are additive. For example if Start Bit and Parity errors exist, the code displayed will be 3. Below is a list of possible errors.

ERROR	CODE
Start bit	1
Parity	2
Framing	4
Uncertain	8
Display field not found	10
Display field too long	20
'ESC' character received	40
Unprocessed message in buffer	10

CODE EXPLANATION

1. **Start bit:** Displayed when the start character is missing or incorrect.
2. **Parity bit:** A redundant bit added to a group of bits in which the total number of binary 1's (or 0's) is always odd or even. An error is displayed if the parity number is not what is specified.
3. **Framing:** A code display when the number of bits within the data format is greater or less than specified.
4. **Uncertain:** There is an error but none of the codes represent it.
5. **Display field not found:** Display field not present.
6. **Display field length:** A code displayed when the number of bits within the numeric display field is greater or less than specified.
7. **'ESC' received:** An illegal ESC character is within the data stream.
8. **Unprocessed message:** Previous message is still in the buffer.

NOTE: Items 7 & 8 are primarily used by programmers that are developing their own driver.

CONNECTION LEADS

If the serial data input leads are open or disconnected from the data source or the display, the Remote Display will display HELP. When the data connection is made, the display will remove the letters HELP and appear blank, waiting for the first message to be sent.

CONNECTION TO A PERSONAL OR IBM COMPATIBLE COMPUTER

When the RD Option is ordered with the purchase of a Raceclock, the mating connector for the serial data port is supplied. Using this connector, wire the serial data port to the COM1 or COM2 serial port on the computer. These ports are usually present on either a 9-Pin or 25-Pin "Sub D" connector with the 9-Pin connector usually being COM1.

9 PIN CONNECTOR

Connect Pin 1 from the RD serial connector to pin 3.

Connect Pin 3 from the RD serial connector to pin 5.

25 PIN CONNECTOR

Connect Pin 1 from the RD serial connector to pin 2.

Connect Pin 3 from the RD serial connector to pin 7.

4.1 SERIAL DATA FORMAT WHEN USED WITH FINISH LYNX

The serial data transmitted to the Raceclock (RD Option), must be transmitted in the following format using the Finish Lynx Scoreboard Script: ElectroA.Iss available at:

<http://www.finishlynx.com>. Select Download - Displays - Electro Numerics (Raceclock) and the script file ElectroA.Iss. Using the Finish Lynx setup software, select **Options** and verify that the software is sending information in the following format:

Scoreboard:	Scoreboard
Status:	Running
Script:	Electro-Flip.Iss
Code set:	single byte
Serial port:	COM1 (or as required)
Baud:	1200
Data bits:	8
Parity:	Even (E)
Stop bits:	1.0
Running time:	Normal
Pause time:	3.0
Offset:	0.000
Auto break:	Off
Results:	Auto Always send place (checked)
Paging	Checked
Size:	1 (single line display)
Time:	5.0
Time Precision:	<on screen>

Note that cable CA45-50 connects the serial data port on the RACECLOCK to the Finish Lynx timing system. This cable is an accessory item and is not automatically provided with the RD option.

5.0 TRIPOD STANDS TS02 SETUP INSTRUCTIONS

 *WHEN USED ACCORDING TO THESE INSTRUCTIONS, THESE STANDS WILL SAFELY SUPPORT YOUR RACECLOCK.*

- 1) Set the stand on hard, level and even ground so that the legs evenly support the weight.
- 2) Fully extend the legs so the cross braces are horizontal. Tighten the leg (lower) knob securely.
- 3) Install the RACECLOCK support bracket on the stand pipe and tighten the upper knob securely.
- 4) With the support bracket at its lowest position, mount the RACECLOCK on the support bracket and insert the bolt through the RACECLOCK bottom flange and the support bracket then install the wing-nut.
- 5) If greater height is desired, loosen the stand pipe (upper) hand knob, raise the RACECLOCK, then securely tighten the hand knob.

CAUTION:

- ***NEVER RAISE THE HEIGHT ABOVE SEVEN FEET (TS02) MEASURED FROM THE GROUND TO THE BOTTOM OF THE DIGITS.***
 - ***IF THERE IS A DANGER OF THE STAND BEING BUMPED, AND ON WINDY DAYS, PROVIDE TIE-DOWNS, SANDBAGS OR SOMEONE TO BRACE THE STAND.***
- 6) When lowering the stand, support the RACECLOCK before loosening the stand pipe (upper) hand knob.

6.0 USING YOUR CLOCK IN INCLEMENT WEATHER



RACECLOCKS are weather resistant but not “waterproof” and can be damaged if water is permitted to get inside.

If you suspect that rain may be present during a race, you should protect your clock with a waterproof covering. We recommend covering your clock with a clear plastic bag (a large clear “yard bag” may be used). After placing the bag over the clock, pull the excess plastic towards the underside of the clock so the clock face is covered by only a single, wrinkle-free, layer of plastic. Then, use masking tape to hold the excess plastic in position and keep it from flapping in the wind. The clock digits will remain visible through the clear plastic and the clock controls will continue to be accessible as well.

7.0 WARRANTY & SERVICE

WARRANTY:

Each *RACECLOCK* is covered by the following limited warranty for 18 months from the date of shipment from Electro-Numerics, Inc., F.O.B. Temecula, California.

"Electro-Numerics Incorporated warrants these products to be free of defects in material and workmanship for eighteen months from date of shipment to the original customer. This warranty on materials and workmanship may be considered as unconditional provided that, in the opinion of Electro-Numerics, the equipment has not been mechanically, environmentally or electrically abused and has been installed, maintained and operated within the limits of rated or normal usage.

Defective products must be sent, transportation charges prepaid with notice of the defect, to our plant in Temecula, CA.

This warranty is limited, at the option of Electro-Numerics, to repair, replacement, or an appropriate credit adjustment not to exceed the original equipment sales price. All warranty freight charges are F.O.B., our plant, Temecula, CA. Electro-Numerics assumes no liability in connection with the sales of its products beyond that stated above and is not responsible for any incidental or consequential loss or damage which might result from a failure of any Electro-Numerics product."

SERVICE:

Products being returned for service should be sent, freight prepaid, to Electro-Numerics, Inc., 42213 Sarah Way, Temecula, CA, U.S.A. to the attention of the Repair Department with a full description of the problem or reason for return. All items sent in for service are subject to a minimum evaluation charge of \$65.00 in the event that the product is found to be out-of-warranty or, if under warranty, not in need of additional service. Out-of-Warranty service and repair charges will be quoted on a case-by-case basis. All repaired products will be shipped to you F.O.B., Temecula, CA.

Should your *RACECLOCK* need service, contact Electro-Numerics Customer Service at Tel: **800-854-8530** (U.S.A.) or 951-699-2437. You may fax us at: 951-695-7246 or send Email to: sales@ElectroNumerics.com.

ELECTRO-NUMERICS, INC.

42213 Sarah Way, Temecula CA 92590 U.S.A.

Tel: (951) 699-2437 Fax: (951) 695-7246