

MICRO-P MIGHTY-1 MIGHTY-5 SERIES B OWNERS MANUAL



ELECTRO-NUMERICS, INC.

CONTENTS

SECTION NO:	PAGE NO:
1. INTRODUCTION	1
2. RECEIVING AND UNPACKING	2
3. SAFETY CONSIDERATIONS	2
4. CONNECTOR WIRING INFORMATION	3
5. FRONT PANEL CONFIGURATIONS.....	5
6. METER KEYPAD FUNCTIONS	5
7. SCALING METHODS.....	7
8. SETTING MENU LOCKOUTS	8
9. METER SETUP AND PROGRAMMING	10
10. DC VOLTS & AMPS	20
11. PROCESS SIGNAL INPUTS	22
12. THERMOCOUPLES.....	24
13. PT100 RTD'S	26
14. STRAIN GAUGES AND POTENTIOMETERS	28
15. AC (RMS) VOLTS & AMPS.....	30
16. LOAD CELLS AND MICROVOLT INPUTS	32
17. DUAL SETPOINT CONTROLLER	34
18. ANALOG OUTPUT	36
19. RS-232 AND RS-485 INTERFACE	37
20. 5, 10 AND 24 VDC EXCITATION OUTPUTS	40
21. DIGITAL CONTROL INPUTS.....	41
22. MECHANICAL ASSEMBLY, MICRO-P & MIGHTY-1	42
23. MOUNTING AND DIMENSIONS, MICRO-P & MIGHTY-1	43
24. MIGHTY-5 POWER SUPPLY	44
25. MECHANICAL ASSEMBLY, MIGHTY-5	45
26. MOUNTING AND DIMENSIONS, MIGHTY-5	46
27. CONNECTORS, (All Models)	47
28. CALIBRATION (Also See "SCALING", Section 32)	47
29. SPECIFICATIONS	47
30. WARRANTY & REPAIR POLICY	51
31. GLOSSARY OF TERMS	52

Owners Manual
P/N **500-218** Revision **U**
January, 2007



Note that CE and UL certifications only apply to Micro-P meters and do not apply to models Mighty-1 and Mighty-5.

The Micro Series meters, which include models Micro-P, Mighty-1 and Mighty-5, are versatile, cost effective solutions to a wide variety of monitoring and control applications. These instruments are easily set to produce an accurate display of temperature, pressure, flow, weight, voltage or current.

Front panel push-button or RS-232/RS-485 setup allow the user to customize the unit for a specific application. Digital scaling of zero and span provides direct readout in engineering units. Digital calibration of all ranges eliminates drift associated with potentiometers found in non-microcomputer-based meters. These meters utilize a unique method of analog-to-digital conversion that provides 60 conversions per second (50 for 50 Hz operation) while integrating over a full cycle of the line for maximum noise rejection. Self calibration cycles reduce the average reading rate to 56 per second (47 for 50 Hz). This fast read rate provides an accurate display of peak signal input and quick response in control applications. The adaptive auto filter automatically supplies a time constant compatible with the signal noise level. This ensures stable displayed readings and outputs while responding rapidly to changes of the input signal that exceed a selected threshold value. Selective security lockout of the front panel setup protects against accidental changes to the meter configuration and simplifies use by the operator.

These meters use a lightweight, high-efficiency switching power supply that operates from either AC or DC voltages and complies with safety regulations. The meter can be powered worldwide without changes to the supply. An optional low voltage supply (optional on all models except Mighty-5) operates on 9 to 37 Vdc from batteries or 8 to 28 Vac from sources such as 400 Hz aircraft power. Both supplies have isolated 5 Vdc, 10 Vdc and 24 Vdc excitation supplies to power transducers. All wiring is by removable plugs conforming to IEC950 safety standards. All output options are isolated from meter and power ground by 250 Vac minimum. Enclosures for models Micro-P, Mighty-1 are designed for indoor panel mounting. Model Migthy-5 features a NEMA-4X case for outdoor mounting.

The dual setpoints have two form C (8A @ 250 Vac) relays or solid state relay outputs for alarm and control capabilities. Either setpoint may be latching or nonlatching and may be separately configured to be energized above or below the setpoint or in a fail-safe mode. Outputs may also be selected to operate from the filtered signal to reduce relay chatter or from the unfiltered signal for fast response. Snubber circuits and programmable relay switching time delay extend relay contact life.

Isolation of the 0 to 20 mA (4/20 mA) and 0 to +10V analog outputs eliminate ground loop problems. The output may be scaled by front panel push-buttons or RS-232/RS-485. For thermocouples and RTD's, the output is linearized. Depending on the application, the analog output may be selected to operate from the filtered or unfiltered signal input. The 0 to 20 mA (4/20 mA) output will drive up to an 600 Ohm load with 12V compliance

This series offer RS-232 or RS-485 bidirectional communications to interface with computers, PLC's or other digital devices. Two communication protocols are available: a stream-lined Custom ASCII protocol, or the more complex but industry standard Modbus protocol. PC-compatible software is available from Electro-Numerics for programming of the unit via either the RS-232 or RS-485 interface.

2.

RECEIVING AND UNPACKING

Your meter was carefully tested and inspected prior to shipment. Should the meter be damaged in shipment, notify the freight carrier immediately. In the event the meter is not configured as ordered or the unit is inoperable, return the unit to the place of purchase for repair or replacement. Please include a detailed description of the problem.

3.

SAFETY CONSIDERATIONS

Warning : The use of this equipment in a manner other than specified may impair the protection of the device and subject the user to a hazard.

Visually inspect the unit for signs of damage. If the unit is damaged, do not attempt to operate.

This unit must be powered with AC (mains) from 95 to 240 Vac (90 to 300 Vdc) +/- 10% with the high voltage power supply option or with the exception of the Mighty-5, 10 to 34 Vac (10 to 48 Vdc) with the low voltage power supply option. Verify that the proper power option is installed for the power to be used.

This meter has no AC (mains) switch; it will be in operation as soon as power is connected.

Caution: The 95 to 240 Vac (95 to 300 Vdc) mains connector (J1 Pins 1-3) is colored Green to differentiate it from other input and output connectors. The 10 to 34 Vac (10 to 48 Vdc) mains connector is colored brown.





Do not make signal wiring changes or connections when power is applied to the instrument. Make signal connections before power is applied and, if reconnection is required, disconnect the AC (mains) power before such wiring is attempted.

To prevent electrical or fire hazard, do not expose the instrument to excessive moisture.

Do not operate the instrument in the presence of flammable gases or fumes; such an environment constitutes a definite safety hazard. This meter is designed to be mounted in a metal panel.

Verify the panel cutout dimensions and mount according to instructions.

Symbols used

-  - Caution (refer to accompanying documents)
-  - Caution, risk of electric shock
-  - Equipment protected throughout by double insulation or reinforced insulation
-  - Earth (ground) terminal
-  - Both direct and alternating current

Operating environment:

Model Micro-p meters are Class II (double insulated) equipment designed for use in Pollution degree 2 and Installation category (Overvoltage category) II environments. Models Mighty-1 and Mighty-5 do not meet this requirement.

4.

CONNECTOR WIRING INFORMATION

CONNECTOR LOCATION

The econnectors for signal and power are U/L rated screw-clamp terminal blocks that plug into mating jacks on the printed circuit board. Communication connectors are a single RJ11 plug for RS232, dual RJ11 plugs for RS485, or dual RJ45 plugs for RS485 Modbus.

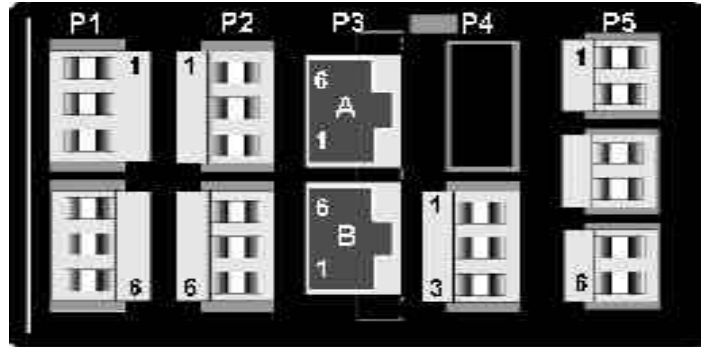

4.2 P1 - POWER AND DIGITAL CONTROLS

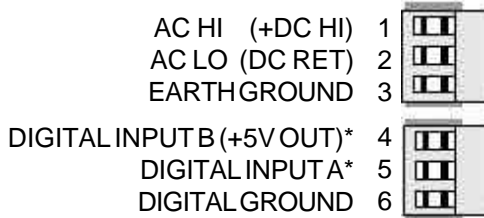

Caution: Hazardous voltages may be present on pins 4, 5 & 6.

Note: Control inputs 1 & 2 are menu selectable.

4.3 P5 - SIGNAL INPUT

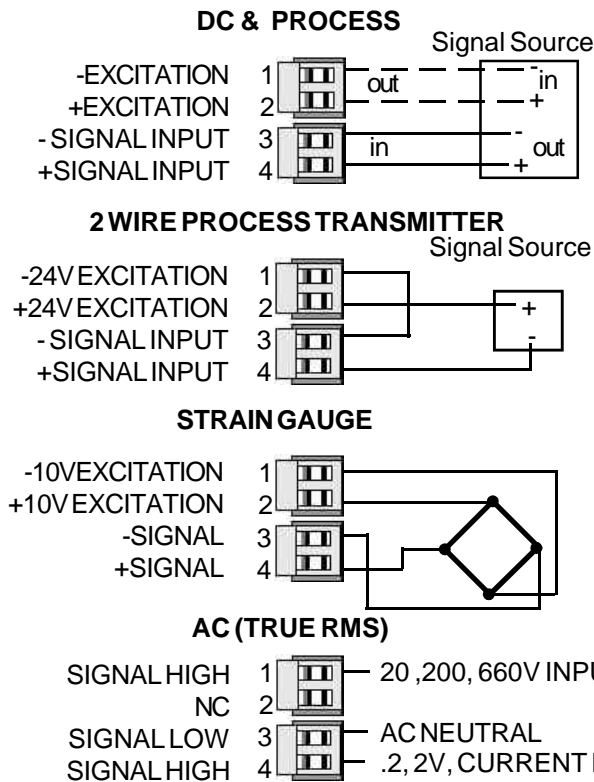

LOAD CELL METER

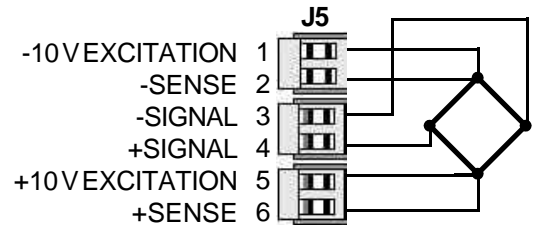

RTD (2-WIRE)

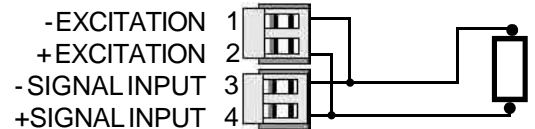

RTD (3-WIRE)

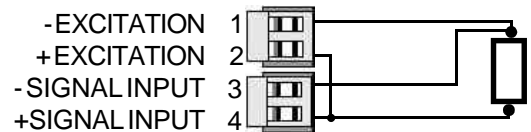

RTD (4-WIRE)

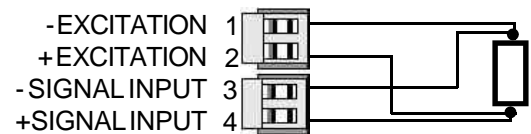

THERMOCOUPLE

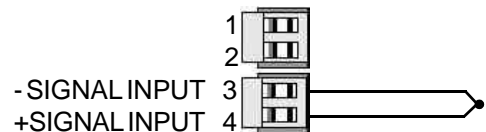



WARNING: Reversing the “signal high” (20, 200, 300V inputs) and “signal low” (AC neutral) terminals, or reversing the “signal high” (0.2, 2V, current inputs) and “signal low” (AC neutral) terminals on the RMS signal conditioner board, results in a hazardous voltage on the secondary circuit that may constitute a risk of electric shock, burn or death.

4.4 P2 - DUAL SETPOINT CONTROLLER

RELAY OUTPUTS (Rev J and earlier)

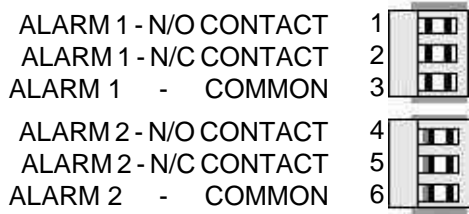

RELAY OUTPUTS (Rev K and later)

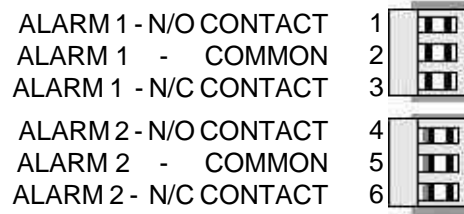

SOLID STATE RELAY OUTPUTS (Rev J and earlier)

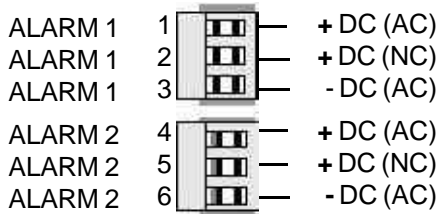

SOLID STATE RELAY OUTPUTS* (Rev K and later)

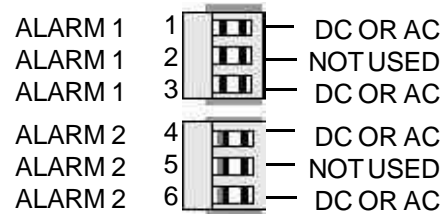

4.5 P3 DIGITAL INTERFACE

RS - 232 INTERFACE - J3A

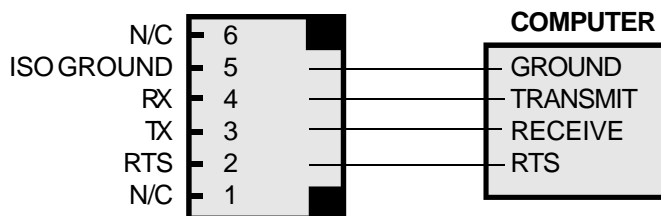

RS - 485 INTERFACE - J3A & J3B

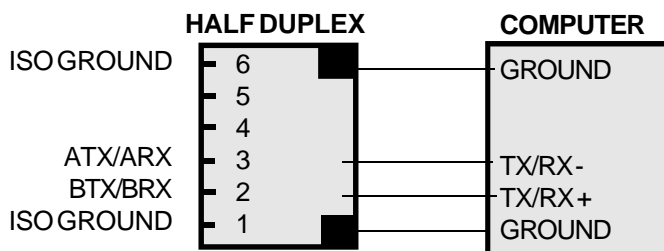
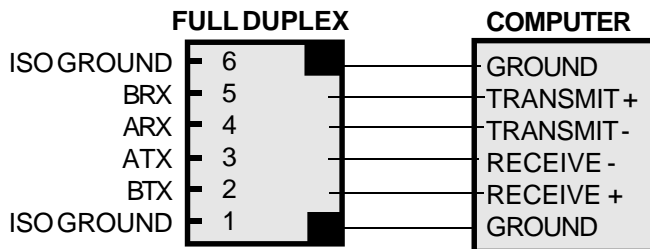

4.6 J4 - ANALOG OUTPUT

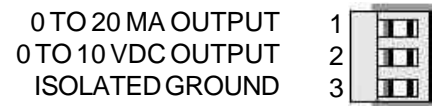

RS - 485 MODBUS - J3A & J3B

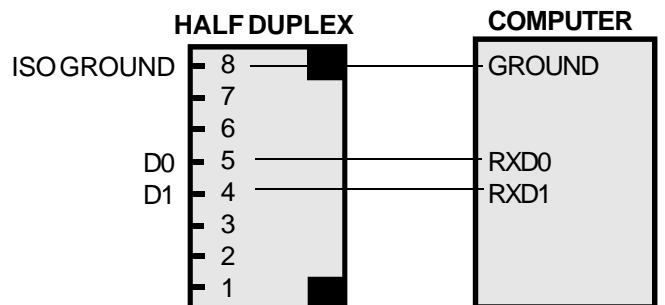
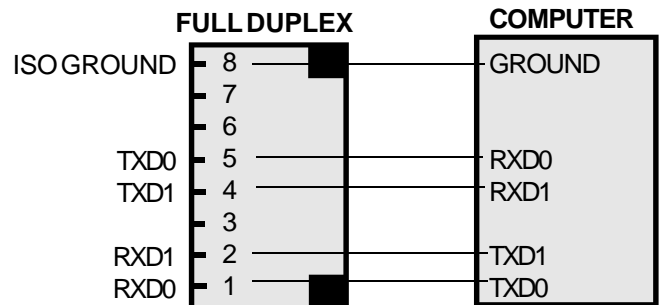

5.

FRONT PANEL CONFIGURATIONS

MICRO-P & MIGHTY-1

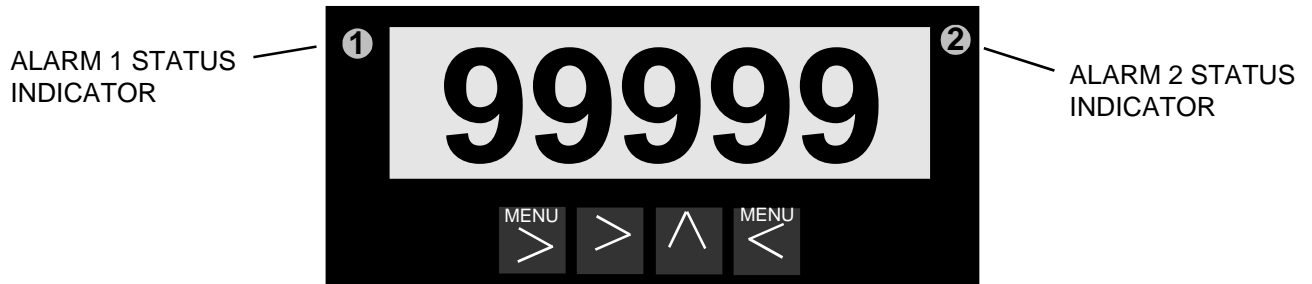

MIGHTY-5

Display board assembly removed from case



6.0

METER KEY PAD FUNCTIONS

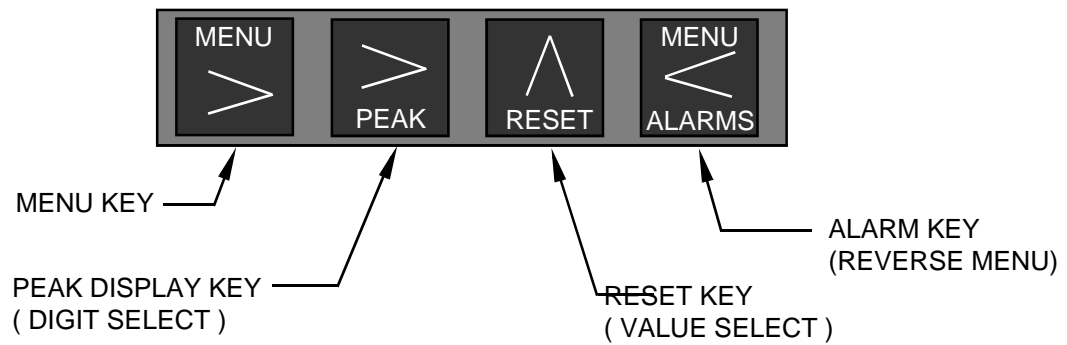

Shown above are the four meter models discussed in this manual. The four keypads on the front of each panel operate in exactly the same way and perform the same functions for all models. The following discussion explains these functions in detail.

MENU KEY FUNCTIONS

Operating Mode

PRESSING



RESULTS

1. Causes meter to change from OPERATING mode to MENU mode.

Menu Mode

PRESSING

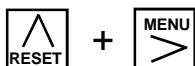

+



RESULTS

2. Each additional press of menu key advances to next menu item until RESET is reached, at which time meter resets to OPERATING mode.
3. While in MENU mode, after performing any change, pressing menu key stores changes made to item values.
4. Resets meter and shifts to OPERATING mode without having to go to end of menu items.

PEAK KEY FUNCTIONS

Menu Mode

PRESSING



RESULTS

1. While meter is displaying a menu item, pressing PEAK key will show values of that menu item. One of the displayed digits will flash, indicating that its value may be changed. To make any digit active, press PEAK key until the digit you wish to change begins to flash.
2. Increments flashing digit by one for each press.

Operating Mode



3. Normally toggles display between PEAK (blinking display) and INPUT values. Key action can also be programmed to display VALLEY, alternating PEAK or VALLEY, or to tare the reading to 0. Periodic horizontal bars at top of display indicate PEAK. Periodic horizontal bars at bottom of display indicate VALLEY.

RESET KEY FUNCTIONS

Operating Mode

Pressing the RESET key and any other key causes several different resets to take place.

PRESSING

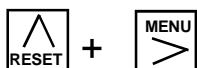

+



+



+



RESULTS

1. Resets all display functions.
2. Resets any alarm conditions.
3. Resets the peak value to the current peak value.

ALARM KEY FUNCTIONS

Operating Mode

PRESSING

ACTIONS



1. 1st. press displays setpoint #1 value, which may be changed by using Digit Select and Value Select Keys.



2. 2nd. press displays setpoint #2 value, which may be changed by using Digit Select and Value Select Keys.



3. 3rd. press returns to INPUT signal value.

Menu Mode



4. Steps display backwards through menu items.

7.0

SCALING METHODS

Three methods are selectable for scaling the meter. These apply to all input board types except the THERMOCOUPLE and RTD temperature boards.

1. Method 1, "Scaling by reading the input signal values"

When using this method, the meter calculates the proper scaling and offset values, entering them into memory. The meter is connected to your sensor and looks at the values of the input signals.

2. Method 2, "Scaling using scale and offset"

This method requires that you calculate the required scale and offset values and enter them into memory when the meter displays SCALE and OFFSET. The meter does not need to be connected to your sensor.

3. Method 3, "Scaling using the coordinates of two points"

In using this method you enter the low input signal value, the display value for the low signal, the high input signal value and the display value for the high input signal. These values are entered manually when menu items **Lo In**, **Lo rd**, **HI In** and **HI rd** are displayed. The meter does not need to be connected to your sensor.

7.1 Accessing scaling method 1: "Reading the input signal values"

1. Remove the input board and verify that the jumpers are in the correct positions for the range you intend to use. Re-install the board.
2. Apply power and press the **MENU** key. The first four menu items for scaling method 1 will appear ahead of all other menu items if scaling method 1 has been selected under the menu item **SEtuP**.
3. To verify that scaling method 1 has been selected, press the **MENU** key until **SEtuP** is displayed. Press the **PEAK** key, and five digits will be displayed. Verify that the 2nd digit from the right is set to 2: **00 20**. If not, press the **PEAK** key until that digit is flashing, then press the **RESET** key until the digit is set to 2. Store the change by pressing the **MENU** key. Go to Section 9 in this manual and perform the procedure "signal scaling by applying a known pressure or weight". Perform any other changes in section 9 that are required for your application.

7.2 Accessing scaling method 2: "Scaling using scale and offset"

1. Remove the input board and verify that the jumpers are in the correct positions for the range you intend to use. Re-install the board.
2. Apply power and press the left **MENU** key until **SEtuP** appears on the display.
3. Press the **PEAK** key, and five digits will appear on the display. Continue pressing the **PEAK** key until the second to the last digit begins to flash **00 00**. Make this digit a **0** by pressing the **RESET** key until **0** appears. Store the change by pressing the **MENU** key.
4. Go to Section 9 under **SEtuP** and select "**Scale Factor and Offset.**" Perform any other changes in Section 9 that are required for your application.

7.3 Accessing scaling method 3: "Scaling using the coordinates of two points"

1. Remove the input board and verify that the jumpers are in the correct positions for the range you intend to use. Re-install the board.
2. Apply power and press the **MENU** key until **SEtuP** appears on the display.
3. Press the **PEAK** key, and five digits will appear on the display. Continue pressing the **PEAK** key until the second digit begins to flash **00 10**. Make this digit a **1** by pressing the **RESET** key until **1** appears. Store the change by pressing the **MENU** key.
4. Go to Section 9. Press **MENU** key until **Lo In** appears. Using the **PEAK** and **RESET** keys, enter the low input value. Push the **MENU** key until **Lo rd** appears. Using the **PEAK** and **RESET** keys, enter the low reading to be displayed. Repeat this procedure for **HI In** and **HI rd**. Perform any other changes in Section 9 that are required for your application.

8.

SETTING MENU LOCKOUTS

For security and ease of operation, any or all program menu items may be disabled. Each function to be disabled is set to "1" in the menu items, "Loc 1", "Loc 2" or "Loc 3". These lockout menu items may in turn be "locked-out" by installing an internal hardware shorting jumper. With the jumper installed, the operator has access only to enabled menu items.

8.1 SETTING HARDWARE LOCKOUT JUMPER

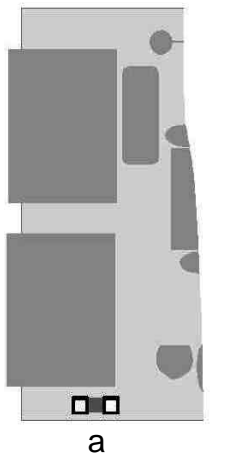

Lockout Jumper

To access the jumper, disassemble the display (see Sections 23, 25 & 26). Remove jumper "a" located on the lower portion of the power supply board next to the input connectors (see figure at left) to enable the software lockouts. Replace the jumper to disable software lockouts.

















Jumper Removed - Loc 1, 2 and 3 are displayed as menu items and allow other menu items to be locked out or enabled.

Jumper Installed - Loc 1, 2 and 3 are not displayed on program menu

Figure 8.1 Power Supply Board

8.2 SETTING SOFTWARE LOCKOUTS

When setting up the meter, it may be necessary to enable some of the menu items. Any digit set to "1" in Loc 1, Loc 2 or Loc 3 indicates that item is locked out. By setting the digit to "0", the item will appear in the menu. Be sure to reset the lockout bit to "1" after selection if you do not want the value changed by the operator. **Note:** The hardware lockout jumper must be removed to access Loc 1, 2 and 3 (see section 8.1)

MENU KEY 	DIGIT SELECT KEY 	VALUE SELECT KEY 
 <p>Press the  key until Loc 1 is displayed.</p>	 <p>Press  to display status and select left digit. Press  again to select another digit. Selected digit will flash. "1" indicates the menu item is disabled. "0" indicates the item is enabled.</p>	 <p>Press  to select "0" or "1" for flashing digit</p> <ul style="list-style-type: none"> 1 - Input type selection 2 - Meter setup, configuration & decimal pt. 3 - Filter selection 4 - Scale or Lo, Hi Input 5 - Offset or Lo, Hi Reading
 <p>Press the  key until Loc 2 is displayed.</p>	 <p>Press  to display status and select left digit. Press  again to select another digit. Selected digit will flash. "1" indicates the menu item is disabled. "0" indicates the item is enabled.</p>	 <p>Press  to select "0" or "1" for flashing digit</p> <ul style="list-style-type: none"> 2 - Alarm Setup 3 - Alarm setpoint value programming 4 - Analog output scaling 5 - Serial interface setup

SETTING SOFTWARE LOCKOUTS (CONT.)

MENU KEY	DIGIT SELECT KEY	VALUE SELECT KEY
<div style="text-align: center; border: 1px solid black; background-color: black; color: white; padding: 5px; font-family: monospace; font-size: 24px; margin-bottom: 10px;">Loc 3</div> <p>Press the key until Loc 3 is displayed.</p>	<div style="text-align: center; border: 1px solid black; background-color: black; color: white; padding: 5px; font-family: monospace; font-size: 24px; margin-bottom: 10px;">1111</div> <p>Press to display status and select left digit. Press again to select another digit. Selected digit will flash. "1" indicates the menu item is disabled. "0" indicates the item is enabled.</p>	<div style="text-align: center; border: 1px solid black; background-color: black; color: white; padding: 5px; font-family: monospace; font-size: 24px; margin-bottom: 10px;">0000</div> <div style="text-align: center; font-size: 18px; margin-bottom: 5px;">2 3 4 5</div> <p>Press to select "0" or "1" for flashing digit</p> <ul style="list-style-type: none"> 2 - View peak value 3 - View alarm setpoints 4 - Reset (peak and latched alarms) 5 - Reset (meter reset)

9.

METER SETUP & PROGRAMMING

Before beginning Setup of the meter, you should first decide on the method of meter scaling as described on page 7. Method 2 is the default setting shipped from the factory. Scaling method 1 does not apply to thermocouples or RTD's. Starting on page 11, proceed through the Setup menu with **InPut**, **SEtuP** and **ConFG**. Under **SEtuP**, if you see **00** (scaling method 1, scaling by reading the input signals), and after a meter **ReSet**, you must connect the meter to your sensor or transducer and use the following procedure to scale the meter. If you select scaling method 2 or 3, *this procedure does not apply*.

MENU KEY	DIGIT SELECT KEY	VALUE SELECT KEY
<p>Lo in Low signal input value (not available for tC & rtd)</p>	<p>0.021 Set the input signal to zero or a known low value</p>	<p>0.021 Press the key to store the low signal input.</p>
<p>Hi In High Signal Input Value</p>	<p>20.094 Set the input signal to a known high value</p>	<p>20.094 Press the key to store the high signal input.</p>
<p>Lo rd Set Low Displayed Reading for Low Signal Input</p>	<p>0.0000 0.0000 0.0000 0.0000 0.0000 Select digit. Digit will flash</p>	<p>0.000 Select 0 through 9 for flashing digit. Decimal point location is fixed by dEC.Pt.</p>
<p>Hi rd Set High Displayed Reading for High Signal Input</p>	<p>0.0000 0.0000 0.0000 0.0000 0.0000 Select digit. Digit will flash</p>	<p>0.000 Select 0 through 9 for flashing digit. Decimal point location is fixed by dEC.Pt.</p>

MENU KEY 

DIGIT SELECT KEY 

VALUE SELECT KEY 

TEMPERATURE SIGNAL CONDITIONER

<p>InPut Input signal type</p>	<p>tC Thermocouple</p> <p>Note: Display  = K</p>	<table border="1"> <tr> <td>J°F</td><td>J°C</td><td>K°F</td><td>K°C</td><td>t°F</td> </tr> <tr> <td>t°C</td><td>E°F</td><td>E°C</td><td>S°F</td><td>S°C</td> </tr> <tr> <td>r°F</td><td>r°C</td><td>n°F</td><td>n°C</td><td>Types</td> </tr> </table> <p>J, K, T, E, N, S, R in °C or °F</p>	J°F	J°C	K°F	K°C	t°F	t°C	E°F	E°C	S°F	S°C	r°F	r°C	n°F	n°C	Types					
	J°F	J°C	K°F	K°C	t°F																	
t°C	E°F	E°C	S°F	S°C																		
r°F	r°C	n°F	n°C	Types																		
<p>rtd Pt 100 Ohm RTD</p>	<table border="1"> <tr> <td>4d °F</td><td>4d °C</td><td>DIN 4-wire</td> </tr> <tr> <td>4A °F</td><td>4A °C</td><td>ANSI 4-wire</td> </tr> <tr> <td>3d °F</td><td>3d °C</td><td>DIN 3-wire</td> </tr> <tr> <td>3A °F</td><td>3A °C</td><td>ANSI 3-wire</td> </tr> <tr> <td>2d °F</td><td>2d °C</td><td>DIN 2-wire</td> </tr> <tr> <td>2A °F</td><td>2A °C</td><td>ANSI 2-wire</td> </tr> <tr> <td>Short</td><td colspan="2">Compensation for 2-wire lead resistance</td> </tr> </table>	4d °F	4d °C	DIN 4-wire	4A °F	4A °C	ANSI 4-wire	3d °F	3d °C	DIN 3-wire	3A °F	3A °C	ANSI 3-wire	2d °F	2d °C	DIN 2-wire	2A °F	2A °C	ANSI 2-wire	Short	Compensation for 2-wire lead resistance	
4d °F	4d °C	DIN 4-wire																				
4A °F	4A °C	ANSI 4-wire																				
3d °F	3d °C	DIN 3-wire																				
3A °F	3A °C	ANSI 3-wire																				
2d °F	2d °C	DIN 2-wire																				
2A °F	2A °C	ANSI 2-wire																				
Short	Compensation for 2-wire lead resistance																					

DC SIGNAL CONDITIONER

<p>dC U DC Volts</p>	<table border="1"> <tr> <td>0.2U</td><td>2.0U</td><td>20.0U</td> </tr> <tr> <td>200.0U</td><td>660.0U</td><td></td> </tr> </table> <p>0.2, 2, 20, 200, 660 V FS</p>	0.2U	2.0U	20.0U	200.0U	660.0U	
0.2U	2.0U	20.0U					
200.0U	660.0U						
<p>dC A DC Amperes</p>	<table border="1"> <tr> <td>2.0a</td><td>20.0a</td><td>200.0a</td><td>5.0A</td> </tr> </table> <p>2, 20, 200 mA, 5 A FS</p>	2.0a	20.0a	200.0a	5.0A		
2.0a	20.0a	200.0a	5.0A				
<p>rAtio Strain Gauge</p>	<table border="1"> <tr> <td>0.2U</td><td>2.0U</td><td>20.0U</td> </tr> </table> <p>0.2, 2, 20 V FS</p>	0.2U	2.0U	20.0U			
0.2U	2.0U	20.0U					

TRUE RMS SIGNAL CONDITIONER

<p>AC U AC Volts</p>	<table border="1"> <tr> <td>0.2U</td><td>2.0U</td><td>20.0U</td> </tr> <tr> <td>200.0U</td><td>660.0U</td><td></td> </tr> </table> <p>0.2, 2, 20, 200, 660 V FS</p>	0.2U	2.0U	20.0U	200.0U	660.0U	
0.2U	2.0U	20.0U					
200.0U	660.0U						
<p>AC A AC Amperes</p>	<table border="1"> <tr> <td>2.0a</td><td>20.0a</td><td>200.0a</td><td>5.0A</td> </tr> </table> <p>2, 20, 200 mA, 5 A FS</p>	2.0a	20.0a	200.0a	5.0A		
2.0a	20.0a	200.0a	5.0A				

MENU KEY 

DIGIT SELECT KEY 

VALUE SELECT KEY 

LOAD CELL SIGNAL CONDITIONER

InPut Input signal type (continued)	Strn Load cells	<table border="1"> <tr> <td>20.0</td> <td>50.0</td> <td>100.0</td> </tr> <tr> <td>250.0</td> <td>500.0</td> <td></td> </tr> </table> 20, 50, 100, 250, 500 mV FS	20.0	50.0	100.0	250.0	500.0														
	20.0	50.0	100.0																		
250.0	500.0																				
	dC u DC millivolts	<table border="1"> <tr> <td>20.0</td> <td>50.0</td> <td>100.0</td> </tr> <tr> <td>250.0</td> <td>500.0</td> <td></td> </tr> </table> 20, 50, 100, 250, 500 mV FS	20.0	50.0	100.0	250.0	500.0														
20.0	50.0	100.0																			
250.0	500.0																				
SEtuP Meter Setup	00_00 Display selection	0 4 1/2 digits (0.1 Degree) 1 Remote display 2 4 1/2 digits [meter counts by 10] (.01 Degree) 3 3 1/2 digits (1 Degree)																			
	00_00 Line frequency	0 60 Hz 1 50 Hz																			
	00_00 Method of scaling meter	0 Scale and offset 1 Coordinates of 2 points 2 Rdg coordinates of 2 pts																			
	00_00 Rear connector inputs A & B (negative true logic, 0V = true, +5V = false) * A and B both low = function reset A and B both low for all oth- ers except dec. pts. = meter reset	0 A: Reset B: Meter Hold 1 A: Function Reset B: Peak Display 2 *A: Hold B: Peak Display 3 *A: Hold B: Tare 4 *A: Peak Display B: Tare 5 A: Tare B: Reset 6 External Decimal Pts.1 7 External Decimal Pts.2 8 A: Function reset B: Display Blank 9 A: Hold B: Display Blank A *A: Peak Display B: Display Blank B A: Tare B: Display Blank C *A: Valley Display B: Peak display																			
	A & B Logic levels for 6 & 7 <table border="1"> <thead> <tr> <th>A</th> <th>B</th> <th>DP1</th> <th>DP2</th> </tr> </thead> <tbody> <tr> <td>1</td> <td>1</td> <td>XXXXX</td> <td>XXXX.X</td> </tr> <tr> <td>0</td> <td>1</td> <td>XXXX.X</td> <td>XXX.XX</td> </tr> <tr> <td>1</td> <td>0</td> <td>XXX.XX</td> <td>XX.XXX</td> </tr> <tr> <td>0</td> <td>0</td> <td>XX.XXX</td> <td>X.XXXX</td> </tr> </tbody> </table>	A	B	DP1	DP2	1	1	XXXXX	XXXX.X	0	1	XXXX.X	XXX.XX	1	0	XXX.XX	XX.XXX	0	0	XX.XXX	X.XXXX
A	B	DP1	DP2																		
1	1	XXXXX	XXXX.X																		
0	1	XXXX.X	XXX.XX																		
1	0	XXX.XX	XX.XXX																		
0	0	XX.XXX	X.XXXX																		

MENU KEY 

DIGIT SELECT KEY 

VALUE SELECT KEY 

ConFG Meter Configuration	00 _ _ 0 Operates as a rate of change meter Extended version only	0 Not rate of change 1 Rate x 0.1 2 Rate x 1 3 Rate x 10 4 Rate x 100 5 Rate x 1000 6 Rate x 10000
	00 _ _ 0 Operation of front panel "Peak" button	0 Peak (Max Rdg) 1 Valley (Min Rdg) 2 Peak (1st push) Valley (2nd push) 3 Front panel Tare
	00 _ _ 0 Scaling for nonlinear input Extended version only	0 Linear input 1 Custom curve
FiLtr Filtering	00000 Alarm filtering	0 Output is unfiltered 1 Output is filtered
	00000 Peak and Valley filtering	0 Peak/Valley unfiltered 1 Peak/Valley filtered
	00000 Display filtering	0 Batch average, 16 rdgs 1 Display filtered signal
	00000 Adaptive filter response	0 Low threshold level 1 High threshold level
	00000 Input signal filtering	0 Autofilter 1 Batch avg, 16 rdgs. 2 Moving avg, .08 sec. 3 Moving avg, .15 sec. 4 Moving avg, .3 sec. 5 Moving avg, .6 sec. 6 Moving avg, 1.2 sec. 7 Moving avg, 2.4 sec. 8 Moving avg, 4.8 sec. 9 Moving avg, 9.6 sec. A Unfiltered

MENU KEY 

DIGIT SELECT KEY 

VALUE SELECT KEY 

<p>dEc.Pt Decimal point selection</p>	<p>d_ddd</p>	<p>d_ddd dd_ddd ddd_dd dddd_d dddd. ._ddd</p>
<p>(Scale and Offset selected) SCALE Scale factor multiplier (not available for tC)</p>	<p>0.0000 0.0000 0.0000 0.0000 0.0000 0.0000</p>	<p>Select 0 through 9 for flashing digit and decimal point location when decimal point is flashing</p>
<p>OFFSt Offset or Zero Value</p>	<p>0.0000 0.0000 0.0000 0.0000 0.0000</p>	<p>Select 0 through 9 for flashing digit. Decimal point location is fixed by dEC.Pt selection</p>
<p>(coordinates of 2 pts method) Lo in Low signal input value (not available for tC & rtd)</p>	<p>0.0000 0.0000 0.0000 0.0000 0.0000</p>	<p>Select 0 through 9 for flashing digit. Decimal point location is fixed by input range chosen.</p>
<p>Lo rd Low Displayed Reading at Low Signal Input</p>	<p>0.0000 0.0000 0.0000 0.0000 0.0000</p>	<p>Select 0 through 9 for flashing digit. Decimal point location is fixed by dEC.Pt selection</p>
<p>Hi In High Signal Input Value</p>	<p>0.0000 0.0000 0.0000 0.0000 0.0000</p>	<p>Select 0 through 9 for flashing digit. Dec. pt. location determined by input range chosen.</p>
<p>Hi rd High Displayed Reading at High Signal Input</p>	<p>0.0000 0.0000 0.0000 0.0000 0.0000</p>	<p>Select 0 through 9 for flashing digit. Decimal location is fixed by dEC.Pt selection.</p>
<p>rd0 In (custom curve only) Corrects for zero errors</p>	<p>04.000 Value set to actual voltage or current input at zero</p>	<p>Select 0 through 9 for flashing digit.</p>
<p>ALSEt Alarm Operation Setup (Only enabled if relay output is installed).</p>	<p>00000 Relay state when alarm is active</p>	<p>0 Relay 1 on, Relay 2 on 1 Relay 1 off, Relay 2 on 2 Relay 1 on, Relay 2 off 3 Relay 1 off, Relay 2 off</p>

<p>ALSEt (continued) Alarm Operation Setup (Only enabled if relay output is installed).</p>	<p>00000 Alarm latches or auto reset</p>	<p>0 Alarm 1 auto reset, Alarm 2 auto reset 1 Alarm 1 latching, Alarm 2 auto reset 2 Alarm 1 auto reset, Alarm 2 latching 3 Alarm 1 latching, Alarm 2 latching</p>
	<p>00000 Alarm operates at and above the setpoint or at and below the setpoint.</p>	<p>0 AL1 active high AL2 active high 1 AL1 active low AL2 active high 2 AL1 disabled AL2 active high 3 AL1 active high AL2 active low 4 AL1 active low AL2 active low 5 AL1 disabled AL2 active low 6 AL1 active high AL2 disabled 7 AL1 active low AL2 disabled 8 AL1 disabled AL2 disabled</p>
	<p>00000 Selection of Hysteresis mode or Band Deviation mode of alarms.</p>	<p>0 AL1 Band deviation AL2 Band deviation 1 AL1 Hysteresis AL2 Band deviation 2 AL1 Band deviation AL2 Hysteresis 3 AL1 Hysteresis AL2 Hysteresis 4 No deviation or hysteresis in menu</p>
	<p>00000 Number of readings in the alarm zone to cause an alarm</p>	<p>0 After 1 reading 1 After 2 readings 2 After 4 readings 3 After 8 readings 4 After 16 readings 5 After 32 readings 6 After 64 readings 7 After 128 readings</p>

dEU1H Amount of deviation or hyste-resis - Alarm 1 (only enabled if relay output is installed).	<u>00000</u> <u>00000</u> <u>00000</u> <u>00000</u> <u>00000</u> When the value is >0, alarms operate above and below setpoint by the value entered.	Select 0 through 9 for flashing digit.
dEU2b Amount of deviation or hyste-resis - Alarm 2 (only enabled if relay output is installed).	<u>00000</u> <u>00000</u> <u>00000</u> <u>00000</u> <u>00000</u> When the value is >0, alarms operate above and below setpoint by the value entered.	Select 0 through 9 for flashing digit.
An Set Setup of analog output. (only enabled if analog output board is installed).	<u>00</u> Calibrated output is current or voltage.	<u>0</u> 0-20 mA current output <u>1</u> 0-10V voltage output <u>2</u> 4-20 mA current output
	<u>00</u> Analog output filtering	<u>0</u> Analog output unfiltered <u>1</u> Analog output filtered
An Lo Displayed value for min value of voltage or current output	<u>0.0000</u> <u>0.0000</u> <u>.00000</u> <u>0.0000</u> <u>0.0000</u>	Select 0 through 9 for flashing digit. Decimal point location fixed by dEC.Pt
An Hi Displayed value for 10 volts or 20 mA output.	<u>0.0000</u> <u>0.0000</u> <u>0.0000</u> <u>0.0000</u> <u>0.0000</u>	Select 0 through 9 for flashing digit. Decimal point fixed by DEC.Pt selection.
Ser_1 Serial interface setup (if serial interface is installed) Fixed parameters applicable to Custom ASCII Protocol: No parity 8-bit word 1 stop bit	<u>000</u> Output filtering	<u>0</u> Send unfiltered signal <u>1</u> Send filtered signal
	<u>000</u> Baud rate	<u>0</u> 300 <u>4</u> 4800 <u>1</u> 600 <u>5</u> 9600 <u>2</u> 1200 <u>6</u> 19200 <u>3</u> 2400
	<u>000</u> Output rate	<u>0</u> <u>60 Hz</u> <u>50 Hz</u> Line frequency <u>1</u> .28 sec .34 sec <u>2</u> .57 sec .68 sec <u>3</u> 1.1 sec 1.4 sec <u>4</u> 2.3 sec 2.7 sec <u>5</u> 4.5 sec 5.4 sec <u>6</u> 9.1 sec 10.9 sec <u>7</u> 18.1 sec 21.8 sec <u>8</u> 36.3 sec 43.5 sec <u>9</u> 72.5 sec 87 sec

MENU KEY 

DIGIT SELECT KEY 

VALUE SELECT KEY 

<p>Ser 2 Serial interface setup</p>	<p>0000 Line Feed</p>	<p>0 None after carriage return 1 LF after carriage return</p>																																																															
	<p>0000 Alarm data transmitted with meter readings</p>	<p>0 No alarm data 1 Alarm data with reading</p>																																																															
	<p>0000 Command mode or continuous serial data output</p>	<p>0 Continuous output 1 Output on RS-232 / RS-485 command only</p>																																																															
	<p>0000 Meter address for RS-232/RS-485 communication (digit display, address number of meter)</p> <p>Note: Addresses 1 through 15 are denoted by 1 through 9 and A through F. Addresses 16 through 31 use the same character followed by a decimal point.</p>	<table border="1"> <thead> <tr> <th>Meter#</th> <th>Display</th> </tr> </thead> <tbody> <tr><td>1</td><td>1</td></tr> <tr><td>2</td><td>2</td></tr> <tr><td>3</td><td>3</td></tr> <tr><td>4</td><td>4</td></tr> <tr><td>5</td><td>5</td></tr> <tr><td>6</td><td>6</td></tr> <tr><td>7</td><td>7</td></tr> <tr><td>8</td><td>8</td></tr> <tr><td>9</td><td>9</td></tr> <tr><td>10</td><td>A</td></tr> <tr><td>11</td><td>b</td></tr> <tr><td>12</td><td>C</td></tr> <tr><td>13</td><td>d</td></tr> <tr><td>14</td><td>E</td></tr> <tr><td>15</td><td>F</td></tr> <tr><td>16</td><td>0.</td></tr> <tr><td>17</td><td>1.</td></tr> <tr><td>18</td><td>2.</td></tr> <tr><td>19</td><td>3.</td></tr> <tr><td>20</td><td>4.</td></tr> <tr><td>21</td><td>5.</td></tr> <tr><td>22</td><td>6.</td></tr> <tr><td>23</td><td>7.</td></tr> <tr><td>24</td><td>8.</td></tr> <tr><td>25</td><td>9.</td></tr> <tr><td>26</td><td>A.</td></tr> <tr><td>27</td><td>b.</td></tr> <tr><td>28</td><td>C.</td></tr> <tr><td>29</td><td>d.</td></tr> <tr><td>30</td><td>E.</td></tr> <tr><td>31</td><td>F.</td></tr> </tbody> </table>	Meter#	Display	1	1	2	2	3	3	4	4	5	5	6	6	7	7	8	8	9	9	10	A	11	b	12	C	13	d	14	E	15	F	16	0.	17	1.	18	2.	19	3.	20	4.	21	5.	22	6.	23	7.	24	8.	25	9.	26	A.	27	b.	28	C.	29	d.	30	E.	31
Meter#	Display																																																																
1	1																																																																
2	2																																																																
3	3																																																																
4	4																																																																
5	5																																																																
6	6																																																																
7	7																																																																
8	8																																																																
9	9																																																																
10	A																																																																
11	b																																																																
12	C																																																																
13	d																																																																
14	E																																																																
15	F																																																																
16	0.																																																																
17	1.																																																																
18	2.																																																																
19	3.																																																																
20	4.																																																																
21	5.																																																																
22	6.																																																																
23	7.																																																																
24	8.																																																																
25	9.																																																																
26	A.																																																																
27	b.																																																																
28	C.																																																																
29	d.																																																																
30	E.																																																																
31	F.																																																																

MENU KEY MENU
>

DIGIT SELECT KEY PEAK
>

VALUE SELECT KEY RESET
^

Ser 3 Serial interface setup	00000 Full or Half duplex (RS485)	0 Full duplex 1 Half duplex
	00000 Spi start and stop characters	0 Normal continuous mode 1 Special start and stop
	00000 RTS (for single output)	0 Non-latched RTS 1 Single output
	00000 Termination characters	0 Only at end of all items 1 At end of each item
	00000 Data sent in continuous mode	0 Reading 1 Peak 2 Valley 3 Reading + Peak 4 Reading + Valley 5 Reading+Peak+Valley
Ser 4 Serial interface setup	000 Modbus ASCII gap timeout	0 1 second 1 3 seconds 2 5 seconds 3 10 seconds
	000 Serial protocol (Custom ASCII is Laurel protocol)	0 Custom ASCII 1 Modbus RTU 2 Modbus ASCII
	000 Parity	0 No parity 1 Odd parity 2 Even parity
Addr Modbus address	000	123 Set to desired address from 1 to 247

MENU KEY 

DIGIT SELECT KEY 

VALUE SELECT KEY 

<p>Loc 1 Lockout of Menu Items (Lockout switch must be in off position to access Loc 1, 2, 3. See Figure 9.1)</p>	<p>00000 Input type selection</p>	<p>0 Enabled 1 Disabled</p>
	<p>00000 Setup, config & decimal point</p>	<p>0 Enabled 1 Disabled</p>
	<p>00000 Filter</p>	<p>0 Enabled 1 Disabled</p>
	<p>00000 Scale,Lo, Hi Input, -Gain</p>	<p>0 Enabled 1 Disabled</p>
	<p>00000 Offset or Lo, Hi Reading</p>	<p>0 Enabled 1 Disabled</p>
<p>Loc 2 Lockout of Front Panel Keys (Lockout switch must be in off position to access Loc 1, 2, 3. See Figure 9.1)</p>	<p>0000 Alarm Setup</p>	<p>0 Enabled 1 Disabled</p>
	<p>0000 Alarm setpoint programming</p>	<p>0 Enabled 1 Disabled</p>
	<p>0000 Analog output scaling</p>	<p>0 Enabled 1 Disabled</p>
	<p>0000 Serial interface setup</p>	<p>0 Enabled 1 Disabled</p>
<p>Loc 3 Lockout of Front Panel Keys (Lockout switch must be in off position to access Loc 1, 2, 3. See Figure 9.1)</p>	<p>0000 View peak value pushbutton</p>	<p>0 Enabled 1 Disabled</p>
	<p>0000 View alarm setpoints pushbutton</p>	<p>0 Enabled 1 Disabled</p>
	<p>0000 Reset pushbutton (peak and latched alarms)</p>	<p>0 Enabled 1 Disabled</p>
	<p>0000 Reset pushbutton (meter reset)</p>	<p>0 Enabled 1 Disabled</p>

10.

DC VOLTS & AMPS

This section is designed to provide basic meter setup instructions when a direct readout of voltage or current is required. When an external shunt is used to monitor current, the setup for process signals, section 11, should be used. Some menu items, such as leading zero blanking, display filtering, etc., are not discussed in this section and have been set to the most commonly used values. Should these items require change, refer to section 9 for selection information. For configuration of optional boards, see the appropriate section elsewhere in the manual.

10.1 RANGE JUMPER SELECTIONS

Voltage Ranges

FS Input	E1	E2	E3
±200.00 mV	A	f	b
±2.0000 V	A	f	a
±20.000 V	B	h	b
±200.00 V	B	h	a
±300V (UL)	B	g	a
±600V (not UL)	B	g	a

Current Ranges

FS Input	E1	E2	E3
±2.0000 mA	A	e, g	b
±20.000 mA	A	d, g	b
±200.00 mA	A	c, g	b
±5.000 A	A	a, b, g	b

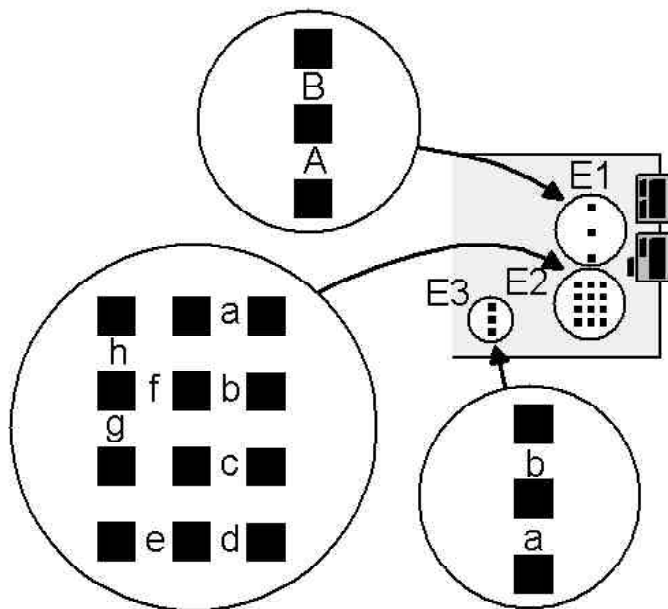

Figure 10.1 DC Signal Conditioner

- Notes**
1. See Section 21 to select 5,10 or 24 Vdc excitation.
 2. Jumpers designated by capital letters require 5mm (0.2 in) jumpers. Jumpers designated by lower case letters require 2.5 mm (0.1 in) jumpers.
 3. Spare jumpers should be stored on single unused jumper posts not associated with capital letter designations

10.2 MENU SELECTION

Display of DC volts or amps is programmed by reading the input signal values (method 1), scale factor and offset (method 2) or coordinate of two points (method 3), see section 7 for a description of these scaling methods.

The following describes Method 2, Scale Factor and Offset.

Whenever the scale factor is 1.0 and offset is zero, the meter displays a direct readout of the signal input in (milli)volts or (milli)amperes. In the following example, the meter is configured for a full scale display of 0 to 20V or 0 to 20mA equals 20.000. Other ranges follow the same setup format. Note that the decimal point selection does not affect the displayed value. A full scale value of 20000 may be displayed as 20.000 milliamps or 20000 microamps. During setup, it may be necessary to enable some menu items that are locked out. See Section 8 for further information.

Menu items	Settings					
InPut			d	C		V
SEtuP	0	0	0	0	0	0
ConFIG	0	0	0	0	0	0
FiLteR	0	0	1	0	0	
Dec.Pt	d	d.	d	d	d	
SCALE	1.	0	0	0	0	0
OFFSt	0	0.	0	0	0	0
Loc 1	0	0	0	0	0	0
Loc 2			0	0	0	0
Loc 3			0	0	0	0

2	0.	0	V
---	----	---	---

If pressing the menu key does not display a menu item, the lockout jumper must be removed. See section 8.1

To see the selection of values for each menu item, go to section 9 and look to the right of the menu item in the menu column.

FRONT PANEL KEYS



Menu



Digit select



Value select



Reverse Menu

Typical Settings



Input

The input is set to 20.000 Vdc. The input type (dc V, dc a, ratio) and input range (20.0V, 2.0V, 5.0A etc.) are set to match the jumpers installed in section 10.1. Pressing the **digit select** key displays the input type setting. This is the only menu selection where the item is selected by pressing the **digit select** key (input type) and the ranges are selected by pressing the **value select** key.

Setup Config

Setup and configuration are set to zero's. Scale & offset are the method of scaling. For these and all other menu items, pressing the **digit select** key displays the settings for that menu item and cause the left hand digit to flash. Every time the **digit select** key is pressed, the next digit to the right flashes. Pressing the **value select** key changes the numeric value of the flashing digit

Filter

Automatic filtering of the display is selected.

Dec.Pt

The decimal point is set to indicate 20 V. When the decimal point is changed, the numbers on the display do not change, only the decimal point location.

Scale

Scale is set to 1.0000. At this setting, the meter is calibrated to read directly in voltage (or current). By setting the scale to 0.1000 and moving the decimal point setting, the meter displays 20.00 instead of 20.000.

Offset

The offset is set a zero when reading voltage or current.

Loc1,2,3

Lockouts are set to zero for programming. All items that should not be changed in normal operation should be set to "1". Install the lockout jumper after programming.

This section provides basic meter setup instructions for a direct readout in engineering units such as psi, rpm, etc. The signal input may come from a transducer or other voltage or current source. Some menu items, such as leading zero blanking, display filtering, etc., are not discussed in this section and have been set to the most commonly used values. Should these items require change, refer to section 10 for selection information. For configuration of optional boards, see the appropriate section elsewhere in the manual.

11.1 RANGE JUMPER SELECTIONS

Voltage Ranges

FS Input	E1	E2	E3
±200.00 mV	A	f	b
±2.0000 V	A	f	a
±20.000 V	B	h	b
±200.00 V	B	h	a
±300V (UL)	B	g	a
±600V (not UL)	B	g	a

Current Ranges

FS Input	E1	E2	E3
±2.0000 mA	A	e, g	b
±20.000 mA	A	d, g	b
±200.00 mA	A	c, g	b
±5.000 A	A	a, b, g	b

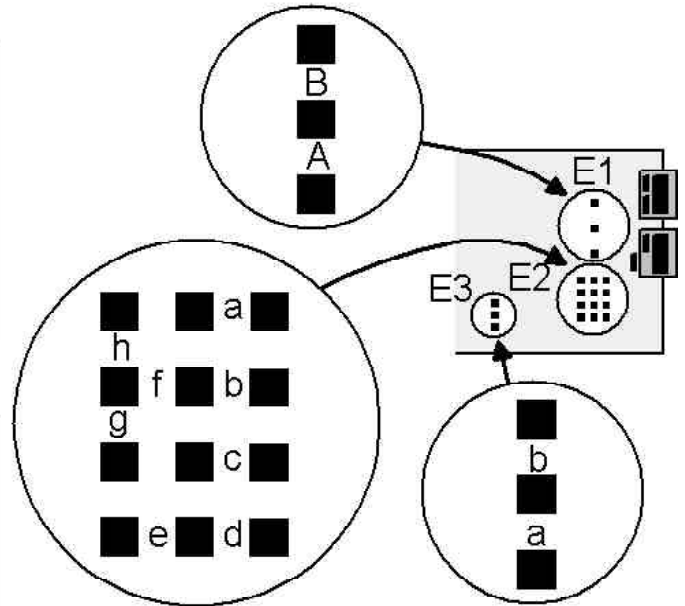

Figure 11.1 DC Signal Conditioner

- Notes**
1. See Section 22 to select 5, 10 or 24 Vdc excitation.
 2. Jumpers designated by capital letters require 5 mm (0.2 in) jumpers. Jumpers designated by lower case letters require 2.5 mm (0.1 in) jumpers.
 3. Spare jumpers should be stored on single unused jumper posts not associated with capital letter designations

11.2 MENU SELECTION

There are three methods of scaling the meters: by reading the signal values (method 1), scale factor and offset (method 2) or coordinates of 2 points (method 3), see section 7. Display in engineering units is most easily programmed using methods 1 or 3. An example of programming method 1 is shown for the "load cells and microvolt inputs", section 16. The following example is for Method 3 where you must enter the four values (low signal input, desired reading at the low signal input, high signal input and desired reading at the high signal input) directly via the front panel pushbuttons or the RS232 interface. To use Method 3, you must select ConFG digit 2, "0" i.e. **00000**.

Method 3: Coordinates of 2 points (example 4 to 20mA = 0 to 100.00)

Enter the values for low signal input (04.000), low display (000.00), high signal input (20.000) and high display (100.00) are entered. The following example uses this scaling method.

Menu items	Settings					
InPut			d	C		A
SEtuP		0	0	0	1	0
ConFiG		0	0	0	0	0
FiLtEr		0	0	1	0	0
Dec.Pt		d	d	d.	d	d
Lo in		0	4.	0	0	0
Lo rd		0	0	0.	0	0
Hi in		2	0.	0	0	0
Hi rd		1	0	0.	0	0
Loc 1		0	0	0	0	0
Loc 2			0	0	0	0
Loc 3			0	0	0	0

	2	0.	0	a
--	---	----	---	---

If pressing the menu key does not display a menu item, the lockout jumper must be removed. See section 8.1

To see the selection of values for each menu item, go to section 9 and look to the right of the menu item in the menu column.

FRONT PANEL KEYS



Menu



Digit select



Value select



Reverse Menu

Typical Settings



Input

The input is set to 20.000 mA. The input type (dc V, dc a, ratio) and input range (20.0V, 2.0V, 20.0A etc.) are set to match the jumpers installed in section 10.1. Pressing the **digit select** key displays the input type setting. This is the only menu selection where the item is selected by pressing the **digit select** key (input type) and the ranges are selected by pressing the **value select** key.

Setup Config

Setup and configuration are set to zero's except for the method of scaling. Coordinates of 2 points is selected. For these and all other menu items, pressing the **digit select** key displays the settings for that menu item and cause the left hand digit to flash. Every time the **digit select** key is pressed, the next digit to the right flashes. Pressing the **value select** key changes the numeric value of the flashing digit

Filter

Automatic filtering of the display is selected.

Dec.Pt

The decimal point is set to indicate two decimal places or in this case, 0.01%. When the decimal point is changed, the numbers on the display do not change, only the decimal point location.

Lo in Hi in

These are the low and high signal inputs; in this example 4 mA and 20 mA. The decimal point is fixed by selecting the 20 mA range at "InPut".

Lo rd Hi rd

These are set to the values to display at 4ma (000.00%) and 20 mA (100.00%). The decimal point is fixed by the selection at "Dec.Pt"

Loc1,2,3

Lockouts are set to zero for programming. All items that should not be changed in normal operation should be set to "1". Install the lockout jumper after programming.

12.

THERMOCOUPLES

12.1 JUMPER SELECTIONS

Thermocouples

Type	Jumpers
J, K, E, N T, R, S	e f
Open Indication	Jumpers
Upscale Downscale	c d

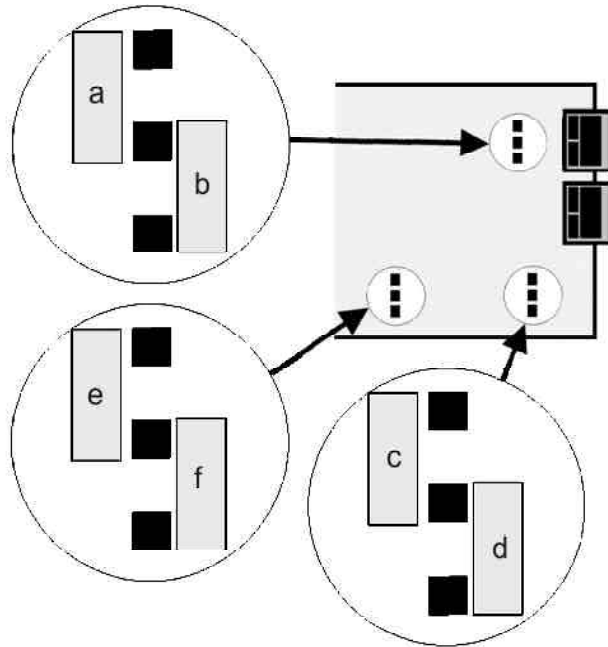

Figure 12.1 Temperature Signal Conditioner

12.2 MENU SELECTION

Thermocouple type and Celsius or Fahrenheit scale are selected by input type. However, Kelvin or Rankine may be displayed by entering the appropriate offset to the selected scale. Although 0.01 degree resolution can be selected, it is not recommended for use with thermocouples.

InPut			t	C		
SEtuP		0	0	0	0	0
ConFiG		0	0	0	0	0
FiLtr		0	0	1	0	0
OFFSt		0	0	0	0	0
Loc 1		0	0	0	0	0
Loc 2			0	0	0	0
Loc 3			0	0	0	0

	K		°	C
--	---	--	---	---

If pressing the menu key does not display a menu item, the lockout jumper must be removed. See section 8.1

To see the selection of values for each menu item, go to section 9 and look to the right of the menu item in the menu column.

FRONT PANEL KEYS



Menu



Digit
select



Value
select



Reverse
Menu

Typical Settings



Input

Pressing the **digit select** key displays the input mode (tc or rtd) and switches between the two. Set the display to tc. Thermocouple type and scale. (types J, K, T, etc and Celsius or Fahrenheit) are selected by pressing the **value select** key. The thermocouple type must match the jumper settings in section 12.1 "**Input**" is the only menu selection where the item is selected by pressing the **digit select** key (input type) and the ranges are selected by pressing the **value select** key.

Setup Config

Setup and configuration are set to zero's. With these settings, the meter automatically sets the decimal point and displays to 0.1 degree resolution. Making "**setup**" 3XXXX instead of 0XXXX removes the decimal point and the meter displays to 1 degree resolution. For these and all other menu items, pressing the **digit select** key displays the settings for that menu item and cause the left hand digit to flash. Every time the **digit select key** is pressed, the next digit to the right flashes. Pressing the **value select** key changes the numeric value of the flashing digit.

Filter

Automatic filtering of the display is selected.

OFFst

The offset value is normally set to 0000.0 to display °C or °F. If °C is selected at "**input**", entering 0273.2 in "**offst**" changes the temperature scale to Kelvin and if °F is selected, entering 0459.7 changes the temperature scale to Rankine.

Loc1,2,3

Lockouts are set to zero for programming. All items that should not be changed in normal operation should be set to "1". Install the lockout jumper after programming.

13.

Pt100 RTD'S

13.1 JUMPER SELECTIONS

Pt 100 RTD connection

Connection	Jumpers
2- or 4-wire	b, e
3-wire	a, e

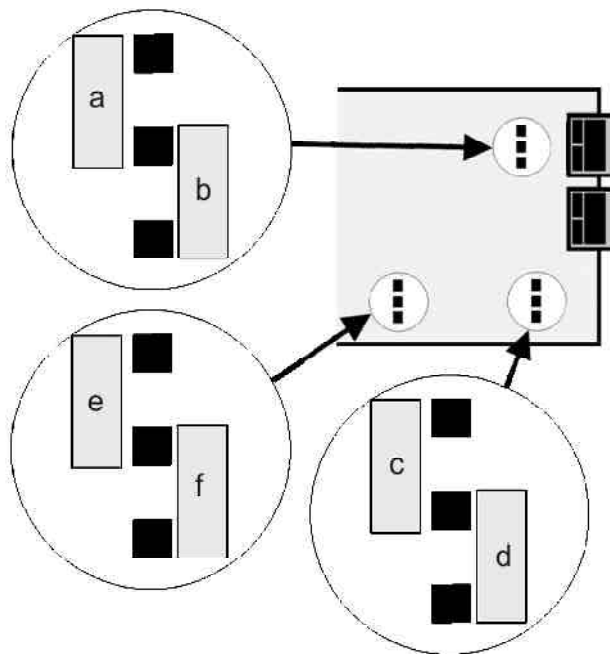

Figure 13.1 Temperature Signal Conditioner

13.2 MENU SELECTIONS

The RTD range is for 100 Ohm Platinum RTD's. There are two types of these RTD's: DIN and ANSI. DIN has a temperature coefficient of 0.00385 Ohms/Ohm/°C and ANSI is 0.003925 Ohms/Ohm/°C. The meter will accept either 2, 3, or 4-wire RTD's. In the input menu, DIN is designated by a "d" following the number of wires and ANSI is designated an "A". The example shown is the setup for a 4-wire DIN RTD.

InPut		r	t	d		
SEtuP		0	0	0	0	0
ConFiG		0	0	0	0	0
FiLtr		0	0	1	0	0
SCALE		1.	0	0	0	0
OFFSt		0	0	0	0.	0
Loc 1		0	0	0	0	0
Loc 2			0	0	0	0
Loc 3			0	0	0	0

4	d		°	F
---	---	--	---	---

If pressing the menu key does not display a menu item, the lockout jumper must be removed. See section 8.1

To see the selection of values for each menu item, go to section 9 and look to the right of the menu item in the menu column.

FRONT PANEL KEYS



Menu



Digit
select



Value
select



Reverse
Menu

Typical Settings



Input

Pressing the **digit select** key displays the input mode (tc or rtd) and switches between the two. Set the display to RTD. Number of wires, RTD type and scale.(2,3,or 4-wire, DIN or ANSI and Celsius or Fahrenheit) are selected by pressing the **value select** key. The number of wires on the RTD must match the jumper settings in section 13.1 "**Input**" is the only menu selection where the item is selected by pressing the **digit select** key (input type) and the ranges are selected by pressing the **value select** key.

Setup Config

Setup and configuration are set to zero's. With these settings, the meter automatically sets the decimal point and displays to 0.1 degree resolution. Making "**setup**" 3XXXX instead of 0XXXX removes the decimal point and the meter displays to 1 degree resolution. For these and all other menu items, pressing the **digit select** key displays the settings for that menu item and cause the left hand digit to flash. Every time the **digit select key** is pressed, the next digit to the right flashes. Pressing the **value select** key changes the numeric value of the flashing digit.

Filter

Automatic filtering of the display is selected.

SCALE

Scale is normally set for 1.0000. However, the scale can be used to correct for errors in the RTD. Some RTD's have the actual resistance at 0 °C marked on the probe or a calibration sheet. To calculate the scale for a particular probe, divide 100 by the actual resistance. If the probe was 99.04 Ohms, the scale would be set to $100/99.04 = 1.0097$.

OFFst

The offset value is normally set to 0000.0 to display °C or °F. If °C is selected at "**input**", entering 0273.2 in "**offst**" changes the temperature scale to Kelvin and if °F is selected, entering 0459.7 changes the temperature scale to Rankine.

Loc1,2,3

Lockouts are set to zero for programming. All items that should not be changed in normal operation should be set to "1". Install the lockout jumper after programming.

14.2 2-WIRE RTD LEAD COMPENSATION

To remove the error caused by lead resistance in a 2-wire RTD, short the wires as close as possible to the RTD element This should be performed after the meter has been setup for 2-wire operation.

InPut		r	t	d			S	h	o	r	t
-------	--	---	---	---	--	--	---	---	---	---	---



Input

Press the **digit select** key and then the **value select** key until until the display indicates "**Short**". Press the **menu** key until the meter momentarily resets.

Reset

The meter will display a value. Press the **digit select** key to store the value.

InPut		r	t	d			2	d		°	C
-------	--	---	---	---	--	--	---	---	--	---	---

Input

Press the **digit select** key and then the **value select** key until until the display indicates "**2d °C**" (or the correct 2-wire range). Press the **menu** key until the meter momentarily resets.

14.1 RANGE JUMPER SELECTIONS

Voltage Ranges

FS Input	E1	E2	E3
± 200.00 mV	A	f	b
± 2.0000 V	A	f	a
± 20.000 V	B	h	b

Notes

1. See Section 22 to select 10Vdc or to remove jumpers for external excitation.
2. Jumpers designated by lower case letters require 2.5mm (0.1 in) jumpers.
3. Spare jumpers should be stored on single unused jumper posts.

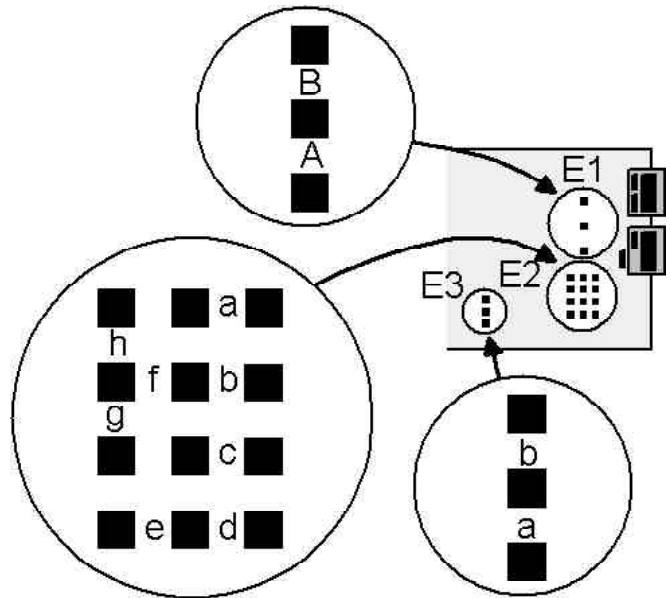

Figure 14. 1 DC Signal Conditioner

14.2 MENU SELECTION

There are three methods of scaling the meters: by reading the signal values (method 1), scale factor and offset (method 2) or coordinates of 2 points (method 3), see section 7. Display in engineering units is most easily programmed using methods 1 or 3. An example of programming method 1 is shown for the "load cells and microvolt inputs", section 16. The following example is for Method 3 where you must enter the four values (low signal input, desired reading at the low signal input, high signal input and desired reading at the high signal input) directly via the front panel pushbuttons or the RS232 interface. To use Method 3, you must select ConFG digit 2, "0" i.e., **00000**.

Method 3: Coordinates of 2 points (example 4 to 20mA = 0 to 100.00)

Enter the values for low signal input (04.000), low display (000.00), high signal input (20.000) and high display (100.00) are entered. The following example uses this scaling method. Signal input is 4 to 20mA and displayed value is 000.00 (at 4mA) to 100.00 (at 20mA). When setting up the meter, it may be necessary to enable some menu items. See Section 8 for further information.

Menu items	Settings					
InPut		r	A	t	I	o
SEtuP		0	0	0	1	0
ConFiG		0	0	0	0	0
FiLtr		0	0	1	0	0
Dec.Pt		d	d	d.	d	d
Lo in		.0	0	0	0	0
Lo rd		0	0	0.	0	0
Hi in		.0	2	0	0	0
Hi rd		1	0	0.	0	0
Loc 1		0	0	0	0	0
Loc 2			0	0	0	0
Loc 3			0	0	0	0

		0.	2	V
--	--	----	---	---

If pressing the menu key does not display a menu item, the lockout jumper must be removed. See section 8.1

To see the selection of values for each menu item, go to section 9 and look to the right of the menu item in the menu column.

FRONT PANEL KEYS



Menu



Digit select



Value select



Reverse Menu

Typical Settings



Input



Setup Config

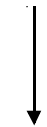

Filter



Dec.Pt

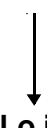

Lo in
Hi in



Lo rd
Hi rd



Loc 1,2,3

The input type (dc V, dc a, ratio) is set to ratio and input range (0.20V, 2.0V, 20.0V) is set to match the jumpers installed in section 14.1 (in this case, 0.2V). In the ratio mode, the meter automatically corrects for any variations in the reading due to changes in the excitation supply voltage. Pressing the **digit select** key displays the input type setting. This is the only menu selection where the item is selected by pressing the **digit select** key (input type) and the ranges are selected by pressing the **value select** key.

Setup and configuration are set to zero's except for the method of scaling. Coordinates of 2 points is selected. For these and all other menu items, pressing the **digit select** key displays the settings for that menu item and cause the left hand digit to flash. Every time the **digit select** key is pressed, the next digit to the right flashes. Pressing the **value select** key changes the numeric value of the flashing digit

Automatic filtering of the display is selected.

The decimal point is set to indicate two decimal places or in this case, 0.01%. When the decimal point is changed, the numbers on the display do not change, only the decimal point location.

These are the low and high signal inputs; in this example 0 mV and 20 mV. The decimal point is fixed by selecting the 0.20 mV range at "**InPut**".

These are set to the values to display at 0 mV (000.00%) and 20 mV (100.00%). The decimal point is fixed by the selection at "**Dec.Pt**"

Lockouts are set to zero for programming. All items that should not be changed in normal operation should be set to "1". Install the lockout jumper after programming.

15.

AC (RMS) VOLTS & AMPS

This section provides basic setup instructions for true RMS voltage or current monitoring. An RMS signal conditioner is required. Some menu items, such as leading zero blanking, display filtering, etc., are not discussed in this section and have been set to the most commonly used values. Should these items require change, refer to section 9 for selection information. For configuration of optional boards, see the appropriate section elsewhere in the manual.

15.1 RANGE JUMPER SELECTIONS

Voltage Ranges

Full Scale Input	Counts	Jumpers
200 mV	20000	g, k
2V	20000	g, j
20V	20000	h, k
200V	20000	h, j
300V (UL)	3000	f, j
600V (not UL)	6000	f, j

Current Ranges

Full Scale Input	Counts	Jumpers
2 mA	20000	e, f, k
20 mA	20000	d, f, k
200 mA	20000	c, f, k
5A	5000	a, b, f, m

RANGE SELECTION VIA JUMPERS

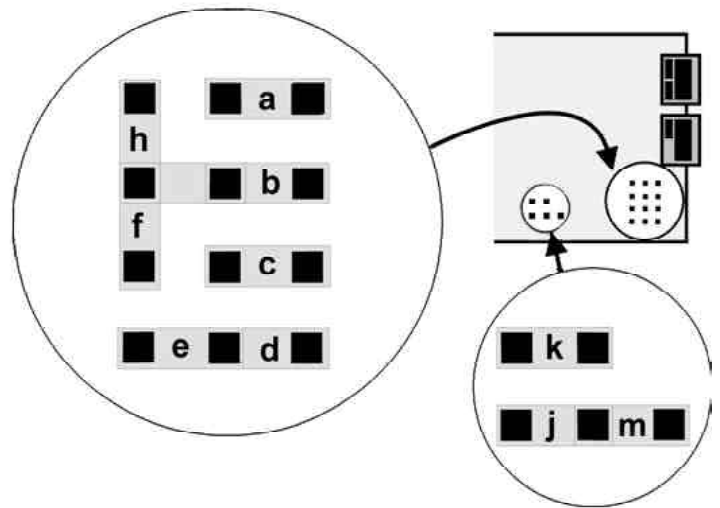

1. Use 2.5 mm (0.1") jumpers.
2. Store spare jumpers on unused jumper post.

Figure 15.1 RMS Signal Conditioner

15.2 MENU SELECTION

Display in engineering units is programmed by reading the input signal values (method 1), scale factor and offset (method 2) or coordinate of two points (method 3), see section 7. When Scale Factor and Offset is selected (this is the factory default), and the scale factor is 1.0 and offset is zero, the meter displays a direct readout of the signal input in (milli)volts or (milli) amperes.

Method 2, Scale Factor and Offset:

In the following example, the meter is configured for a full scale display of 0 to 20V or 0 to 20mA equals 20.000. Other ranges follow the same setup format. Note that the decimal point selection does not affect the displayed value. A full scale value of 20000 may be displayed as 20.000 Volts or 20000 millivolts. When an external shunt or current transformer is used to monitor current, the appropriate scale factor must be entered. A 5A CT input to the meter displays 20000 (2000 when 3 1/2 digit is selected). For an 800 Amp CT, divide 8000 (desired full scale display with 0.1 Amp resolution) by 20000 (full scale when the scale factor is 1.0) for the correct scale factor. Enter 0.4 as a scale factor. During setup, it may be necessary to enable some menu items that are locked out. See Section 8 for further information.

Menu items	Settings										
InPut			A	C		V	2	0	0.	0	V
SEtuP		0	0	0	0	0					
ConFiG		0	0	0	0	0					
FiLtr		0	0	1	0	0					
Dec.Pt		d	d.	d	d	d					
SCALE		1.	0	0	0	0					
OFFSt		0	0.	0	0	0					
Loc 1		0	0	0	0	0					
Loc 2			0	0	0	0					
Loc 3			0	0	0	0					

If pressing the menu key does not display a menu item, the lockout jumper must be removed. See section 8.1

To see the selection of values for each menu item, go to section 9 and look to the right of the menu item in the menu column.

FRONT PANEL KEYS

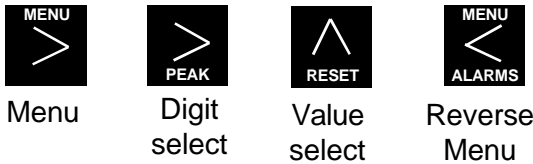

Typical Settings

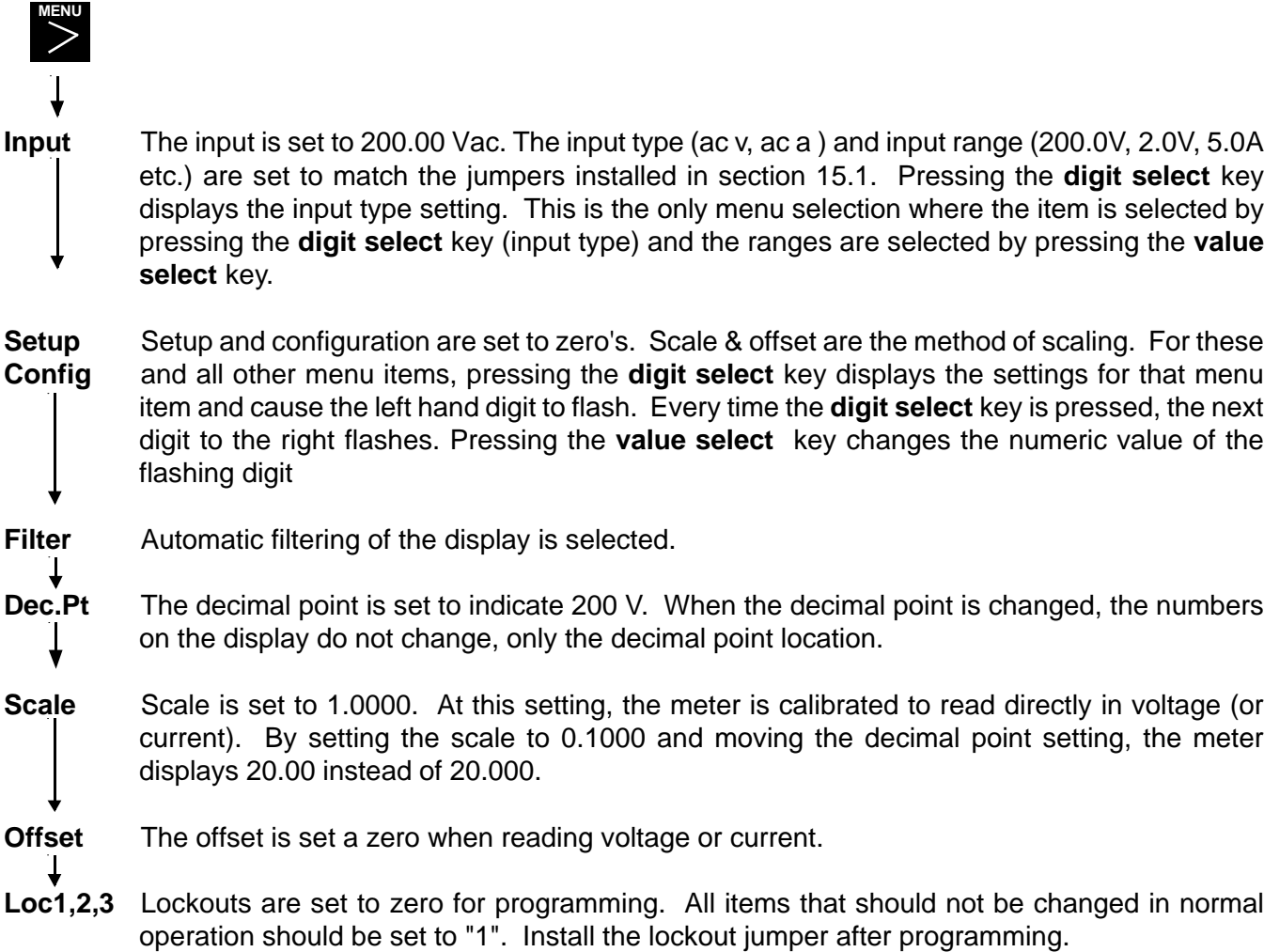

16.

LOAD CELLS AND MICROVOLT INPUTS

This section provides setup instructions for use as a microvoltmeter or with load cells and strain gauges. 10 Volt excitation will power up to four 350 Ohm load cells in parallel. Sense leads may be used to compensate for lead resistance of the excitation supply. For configuration of optional boards, see the appropriate section elsewhere in the manual.

16.1 RANGE JUMPER LOCATIONS

Ranges & Display with Scale Factor = 1

Input	Jumpers	Full scale display
±20 mV	e	±20000
±50 mV	a	±50000
±100 mV	b	±10000
±250 mV	c	±25000
±500 mV	d	±50000

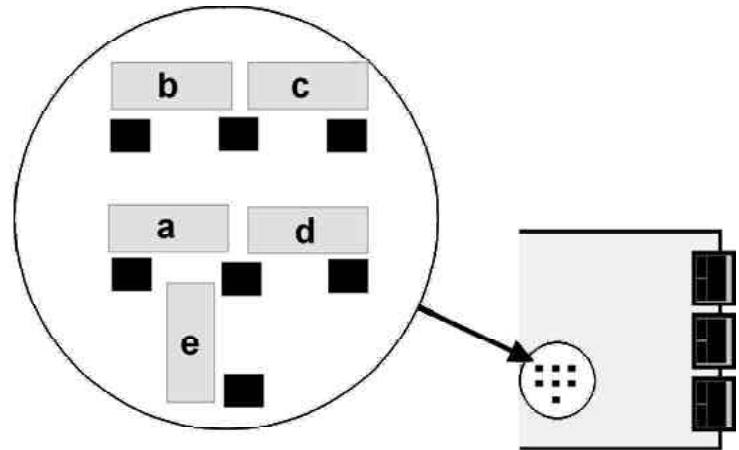

- Notes**
1. See Section 22 to select 10V excitation.
 2. Jumpers are 2.5 mm (0.1 in).

16.2 MENU SELECTION

Figure 16.1 Load Cell Signal Conditioner

There are three methods of scaling the meters: by reading the signal values (Method 1), scale factor and offset (Method 2), or coordinates of 2 points (Method 3), see section 7. Display in engineering units is most easily programmed using methods 1 or 3.

An example of programming Method 2 is shown for "DC volts and amps", Section 10.

The following example is for Method 1, where the low signal input and high signal input values are read directly by the meter and are then stored as Lo in and Hi in. This illustrated by the following example. The full scale range of a load cell is 500 pounds and has an output of 2 mV/V (2 millivolts per volt of excitation). With 10V excitation, the full scale range of 20 mV is selected by jumper (see the above chart), which will display a resolution of 0.01 pounds. With no weight on the scale (load cell), the meter should read 0.00 and with a 500 pound weight on the scale (load cell), the meter should display 500.00 pounds. With no weight on the load cell, press the **Menu Key** to select **Lo in** (low input) and then press the **Digit Select (Peak) Key**. The meter will take readings and display the millivolt value of the input signal. Pressing the **Value Select (Reset) Key** will store this reading as the **Lo in**. Press the **Menu Key** to select **Hi in** (high input), place the 500 pound weight on the scale (load cell) and repeat the procedure the same as for **Lo in**. Press the **Menu Key** to select **Lo rd** (Low Reading) and enter 000.00, then press the **Menu Key** to select **Hi rd** (high reading) and enter 500.00.

Advantages of this Method 1 are accuracy, since reading the value corrects for any error in the transducer, and ease of recalibration. To recalibrate the meter, take readings at 0 and 500 pounds; Lo rd and Hi rd do not need to be reentered. If a 500 pound weight is not available, the same result can be achieved by using any known weight. During Setup, it may be necessary to enable some menu items. See Section 8 for further information.

See Section 11 for an example of scaling using the coordinate of 2 points method (direct data entry) of scaling in engineering units.

Menu items	Settings					
InPut			S	t	r	n
SEtuP	0	0	0	1	0	
ConFiG	0	0	0	0	0	
FiLtr	0	0	1	0	0	
Dec.Pt	d	d	d	d	d.	
Lo in	0	0.	0	0	0	
Lo rd	0	0	0	0	0	
Hi in	2	0.	0	3	2	
Hi rd	1	5	0	0	0	
Loc 1	0	0	0	0	0	
Loc 2			0	0	0	
Loc 3			0	0	0	

2	0.	0	u
---	----	---	---

If pressing the menu key does not display a menu item, the lockout jumper must be removed. See section 8.1

To see the selection of values for each menu item, go to section 9 and look to the right of the menu item in the menu column.

FRONT PANEL KEYS



Menu



Digit select



Value select



Reverse Menu

Typical Settings



Input

The input type (dc v, strain) is set to strain and input range (0.20mV to 500mV) is set to match the jumpers installed in section 16.1(in this case, 20mV). In the strain mode, the meter automatically corrects for any variations in the reading due to changes in the excitation supply voltage. Pressing the **digit select** key displays the input type setting. This is the only menu selection where the item is selected by pressing the **digit select** key (input type) and the ranges are selected by pressing the **value select** key.

Setup Config

Setup and configuration are set to zero's except for the method of scaling. Coordinates of 2 points is selected. For these and all other menu items, pressing the **digit select** key displays the settings for that menu item and cause the left hand digit to flash. Every time the **digit select** key is pressed, the next digit to the right flashes. Pressing the **value select** key changes the numeric value of the flashing digit

Filter

Automatic filtering of the display is selected.

Dec.Pt

The decimal point is set to indicate no decimal place. When the decimal point is changed, the numbers on the display do not change, only the decimal point location.

Lo in
Hi in

These are the low and high signal inputs; in this example 0 mV and 20.032 mV. The Hi in is derived from the full scale calibration of the load cell output. In this case, 2.0032mV/V times the excitation voltage, 10V. The decimal point is fixed by selecting the 20 mV range at "InPut".

Lo rd
Hi rd

These are set to the values to display at 0 mV (0 lbs) and 20.032 mV (15000lbs). The decimal point is fixed by the selection at "**Dec.Pt**"

Loc1,2,3

Lockouts are set to zero for programming. All items that should not be changed in normal operation should be set to "1". Install the lockout jumper after programming.

17.

DUAL SETPOINT CONTROLLER

17.1 OPERATING MODE MENU SELECTION

When setting up the meter, it may be necessary to enable some of the menu items. See Section 8 for further information.

<div style="border: 1px solid black; display: inline-block; padding: 2px;"> MENU KEY MENU > </div>	<div style="border: 1px solid black; display: inline-block; padding: 2px;"> DIGIT SELECT KEY PEAK > </div>	<div style="border: 1px solid black; display: inline-block; padding: 2px;"> VALUE SELECT KEY RESET ^ </div>
<div style="text-align: center; font-size: 2em; font-family: monospace; background-color: black; color: white; padding: 5px; margin-bottom: 10px;">ALSEt</div> <p>Press the MENU > key until ALSEt (Alarm setup) is displayed. See Section 9, ALSEt for detailed selection information for Digits 1 through 5.</p>	<div style="text-align: center; font-size: 2em; font-family: monospace; background-color: black; color: white; padding: 5px; margin-bottom: 10px;">00000</div> <div style="text-align: center; font-size: small; margin-bottom: 5px;">1 2 3 4 5</div> <p>Press PEAK > to display status. Press PEAK > again to select digit. Selected digit will flash.</p>	<div style="text-align: center; font-size: 2em; font-family: monospace; background-color: black; color: white; padding: 5px; margin-bottom: 10px;">20013</div> <div style="text-align: center; font-size: small; margin-bottom: 5px;">1 2 3 4 5</div> <p>Press RESET ^ to select value for flashing digit Digit 1: Relay state in alarm Digit 2: Latching or non-latching output Digit 3: Alarm high, low or disabled Digit 4: Hysteresis or deviation Digit 5: Time delay</p>
<div style="text-align: center; font-size: 2em; font-family: monospace; background-color: black; color: white; padding: 5px; margin-bottom: 10px;">dEU1b</div> <p>Press the MENU > key and dEU1b (Alarm 1 band deviation) or dEU1H (Alarm 1 hysteresis) is displayed if ALSEt digit 4 is not set to 4.</p>	<div style="text-align: center; font-size: 2em; font-family: monospace; background-color: black; color: white; padding: 5px; margin-bottom: 10px;">00000</div> <p>Press PEAK > to display value. Press PEAK > again to select digit. Selected digit will flash.</p>	<div style="text-align: center; font-size: 2em; font-family: monospace; background-color: black; color: white; padding: 5px; margin-bottom: 10px;">00200</div> <p>Using RESET ^ to set digit value 0 to 9, enter deviation value for setpoint1. Relays turn on and off at setpoint if value is zero.</p>
<div style="text-align: center; font-size: 2em; font-family: monospace; background-color: black; color: white; padding: 5px; margin-bottom: 10px;">dEU2H</div> <p>Press the MENU > key and dEU2b (Alarm 2 band deviation) or dEU2H (Alarm 2 hysteresis) is displayed if ALSEt digit 4 is not set to 4.</p>	<div style="text-align: center; font-size: 2em; font-family: monospace; background-color: black; color: white; padding: 5px; margin-bottom: 10px;">00000</div> <p>Press PEAK > to display value. Press PEAK > again to select digit. Selected digit will flash.</p>	<div style="text-align: center; font-size: 2em; font-family: monospace; background-color: black; color: white; padding: 5px; margin-bottom: 10px;">00200</div> <p>Using RESET ^ to set digit value 0 to 9, enter deviation value for setpoint2. Relays turn on and off at setpoint if value is zero.</p>

17.2 NORMAL OPERATION

When deviation and hysteresis are not enabled or deviation is set to zero, the alarm energizes at and above the setpoint and deenergizes below the setpoint if high alarm is selected. The alarm energizes at and below the setpoint and deenergizes above the the setpoint if low alarm is selected. The setpoint value is not displayed if the alarm is disabled.

17.3 BAND DEVIATION



















When deviation is selected from the setup menu, a value is entered for the amount of deviation required. This value represents the number of counts at which the relay will be energized above and below the setpoint. For example, if the setpoint is set to 10,000 and a deviation value of 200 was entered, the relay will activate below 9800 and above 10,200.

17.4 HYSTERESIS

When hysteresis is selected from the setup menu, a value is entered for the amount of hysteresis required. This value represents the number of counts at which the relay will be energized above and deenergized below the setpoint. For example, if the setpoint is set to 10,000 and a hysteresis value of 200 was entered, the relay will activate at 10200 and deactivate at 9800.

17.5 VIEWING AND CHANGING SETPOINTS

When viewing or changing the setpoint values, it is not necessary to enter the setup menu. This allows the meter to continue to make conversions and provide outputs when the setpoint values are displayed.

		
 <p>Press the  key to display Alarm 1 value.</p>	 <p>Alarm value blinks and Alarm 1 LED indicator lights. Press  to select digit.</p>	 <p>Use  to select digit and  to change the digit value, enter setpoint 1 value.</p>
<p>Press  key again to store Alarm 1 value and display Alarm 2 value.</p>	 <p>Alarm value blinks and Alarm 2 LED indicator lights. Press  to select digit.</p>	 <p>Use  to select digit and  to change the digit value, enter setpoint 2 value.</p>
 <p>Press  key again to store alarm 2 value. The meter re-sets and then displays present reading.</p>		

18.

ANALOG OUTPUT

The analog output option provides a 0 to 20 mA and a 0 to 10 Vdc linear signal derived from the displayed reading. The low signal output and high signal output may be set to equal any displayed value. Although both outputs are available, only one is calibrated to specifications. The other output is accurate to +/-1% of the displayed value typical (2%max). To select which output is calibrated, set either current or voltage output from the menu, under **An Set**.

18.1 4 TO 20MA OUTPUT SCALING

The output is scaled by selecting a displayed value for the low signal output and a displayed value for the high signal output. For a current output, the low value is 0mA and the high output is 20mA. To scale a signal for 4 to 20 mA, the following procedure must be used:

1. Desired display value for 20 mA - Desired display value for 4mA = Display span
2. Display span / 4 = Offset value
3. Desired display value for 4mA - Offset value = **An Lo**
4. **An Hi** = Desired display value for 20 mA

18.2 ANALOG OUTPUT SETUP

The following menu items are accessible only with an Analog Output option installed and appropriate lockouts enabled. See Section 8 for further information. Setup Example: 4mA to 20mA out = 5000 counts to 15000 counts (See Section 18.2).

<div style="border: 1px solid black; padding: 2px; display: inline-block;"> MENU KEY MENU > </div>	<div style="border: 1px solid black; padding: 2px; display: inline-block;"> DIGIT SELECT KEY PEAK > </div>	<div style="border: 1px solid black; padding: 2px; display: inline-block;"> VALUE SELECT KEY RESET ^ </div>
<div style="border: 1px solid black; padding: 5px; text-align: center; font-size: 1.5em; margin-bottom: 10px;">An SET</div> <p>Press the MENU > key until An SET (Setup of analog output) is displayed. See section 9, An SET for detailed selection information.</p>	<div style="border: 1px solid black; padding: 5px; text-align: center; font-size: 1.5em; margin-bottom: 10px;">00</div> <p>Press PEAK > to display status. Press PEAK > again to select digit. Selected digit will flash.</p>	<div style="border: 1px solid black; padding: 5px; text-align: center; font-size: 1.5em; margin-bottom: 10px;">12</div> <p style="text-align: center; font-size: small;">1 2 3 4 5</p> <p>Press RESET ^ to select value for flashing digit. Digit 4: Current or Voltage Digit 5: Filtering</p>
<div style="border: 1px solid black; padding: 5px; text-align: center; font-size: 1.5em; margin-bottom: 10px;">An Lo</div> <p>Press the MENU > key until An Lo (Displayed value at 0mA or 0V) is displayed.</p>	<div style="border: 1px solid black; padding: 5px; text-align: center; font-size: 1.5em; margin-bottom: 10px;">00000</div> <p>Press PEAK > to display value. Press PEAK > again to select digit. Selected digit will flash.</p>	<div style="border: 1px solid black; padding: 5px; text-align: center; font-size: 1.5em; margin-bottom: 10px;">02500</div> <p>Press RESET ^ to select value for flashing digit</p>
<div style="border: 1px solid black; padding: 5px; text-align: center; font-size: 1.5em; margin-bottom: 10px;">An Hi</div> <p>Press the MENU > key until An Hi (Displayed value at 20mA or 10V) is displayed.</p>	<div style="border: 1px solid black; padding: 5px; text-align: center; font-size: 1.5em; margin-bottom: 10px;">00000</div> <p>Press PEAK > to display value. Press PEAK > again to select digit. Selected digit will flash.</p>	<div style="border: 1px solid black; padding: 5px; text-align: center; font-size: 1.5em; margin-bottom: 10px;">15000</div> <p>Press RESET ^ to select value for flashing digit</p>

19.

RS-232 AND RS-485 INTERFACE









19.1 OPERATING MODE MENU SELECTION









The following menu items are accessible only with an RS-232 or RS-485 option installed and appropriate lockouts enabled. See Section 13 for further information. Comprehensive details for using all of the serial output features are explained in the Serial Communications Manual which is supplied on disk.

MENU KEY 

DIGIT SELECT KEY 

VALUE SELECT KEY 

<div style="text-align: center; font-size: 24px; font-weight: bold; margin-bottom: 10px;">SEr 1</div> <p>Press the  key until SEr 1 (Serial interface setup 1) is displayed.</p>	<div style="text-align: center; font-size: 24px; font-weight: bold; margin-bottom: 10px;">000</div> <div style="text-align: center; font-size: 12px; margin-bottom: 5px;">1 2 3 4 5</div> <p>Press  to display status. Press  again to select digit. Selected digit will flash.</p>	<div style="text-align: center; font-size: 24px; font-weight: bold; margin-bottom: 10px;">158</div> <div style="text-align: center; font-size: 12px; margin-bottom: 5px;">1 2 3 4 5</div> <p>Press  to select value for flashing digit</p>
	<p>Digit 3: Output filtering</p>	<p>0: Send unfiltered value 1: Send filtered value</p>
	<p>Digit 4: Baud rate</p>	<p>0: 300 baud 1: 600 baud 2: 1200 baud 3: 2400 baud 4: 4800 baud 3: 9600 baud 4: 19200 baud</p>
	<p>Digit 5: Output update rate for continuous mode</p>	<p>0: to 9: 50/60 readings per second to 1 reading every 72 seconds</p>
<div style="text-align: center; font-size: 24px; font-weight: bold; margin-bottom: 10px;">SEr 2</div> <p>Press the  key until SEr 2 (Serial interface setup 2) is displayed.</p>	<div style="text-align: center; font-size: 24px; font-weight: bold; margin-bottom: 10px;">0000</div> <div style="text-align: center; font-size: 12px; margin-bottom: 5px;">1 2 3 4 5</div> <p>Press  to display status. Press  again to select digit. Selected digit will flash.</p>	<div style="text-align: center; font-size: 24px; font-weight: bold; margin-bottom: 10px;">001E</div> <div style="text-align: center; font-size: 12px; margin-bottom: 5px;">1 2 3 4 5</div> <p>Press  to select value for flashing digit</p>
	<p>Digit 2: Line feed</p>	<p>0: No line feed 1: <LF> after <CR></p>
	<p>Digit 3: Sending alarm data</p>	<p>0: No alarm data 1: Send alarm data</p>
	<p>Digit 4: Sending data</p>	<p>0: Send continuously 1: Send on command</p>
	<p>Digit 5: Meter address</p>	<p>1 to F and 0. to F. = Meter #1 to Meter #31</p>

 <p>Press the ^{MENU} > key until SEr 3 (Serial interface setup 3) is displayed.</p>	 <p>Press ^{PEAK} > to display status. Press ^{PEAK} > again to select digit. Selected digit will flash.</p> <p>Digit 1: RS485 Full or half duplex mode</p> <p>Digit 2: Start/Stop characters for continuous mode</p> <p>Digit 3: RTS mode</p> <p>Digit 4: Termination characters</p> <p>Digit 5: Meter address</p>	 <p>Press ^{RESET} ^ to select value for flashing digit</p> <p>0: Full</p> <p>1: Half</p> <p>0: Standard characters</p> <p>1: Special characters</p> <p>0: Normal RTS</p> <p>1: Send single transmission</p> <p>0: After all items</p> <p>1: After each item</p> <p>0: Reading</p> <p>1: Peak</p> <p>2: Valley</p> <p>3: Reading + Peak</p> <p>4: Reading + Valley</p> <p>5: Reading + Peak + Valley</p>
 <p>Press the ^{MENU} > key until SEr 4 (Serial interface setup 4) is displayed.</p>	 <p>Press ^{PEAK} > to display status. Press ^{PEAK} > again to select digit. Selected digit will flash.</p> <p>Digit 3: Modbus ASCII gap timeout</p> <p>Digit 4: Serial Protocol</p> <p>Digit 5: Parity</p>	 <p>Press ^{RESET} ^ to select value for flashing digit</p> <p>0: 1 second</p> <p>1: 3 seconds</p> <p>2: 5 seconds</p> <p>3: 10 seconds</p> <p>0: Custom ASCII</p> <p>1: ModbusRTU</p> <p>2: Modbus ASCII</p> <p>0: None</p> <p>1: Odd</p> <p>2: Even</p>
 <p>Press the ^{MENU} > key until Addr (Modbus address) is displayed. This only appears if a Modbus protocol is selected in Ser 3.</p>	 <p>Press ^{PEAK} > to display status. Press ^{PEAK} > again to select digit. Selected digit will flash.</p>	 <p>Press ^{RESET} ^ to select value for flashing digit. The Modbus address may be set from 1 to 247.</p>

19.2 RS232 INTERFACE CABLE

A RS232 cable, P/N DPM-3-RJ11AD9 to interface the DPM-3 to a PC is available from Transducer Techniques. See section 23, Accessories, for further information

19.3 JUMPER SELECTIONS

RS232 Interface

Jumper g - installed for normal operation

Jumper h - installed when used as a slave display with the RS232 output of another DPM-3 meter.

Jumper j - provides a pull-up resistor on the RTS line.

Note: The board is shipped standard with jumpers **g** and **j** installed

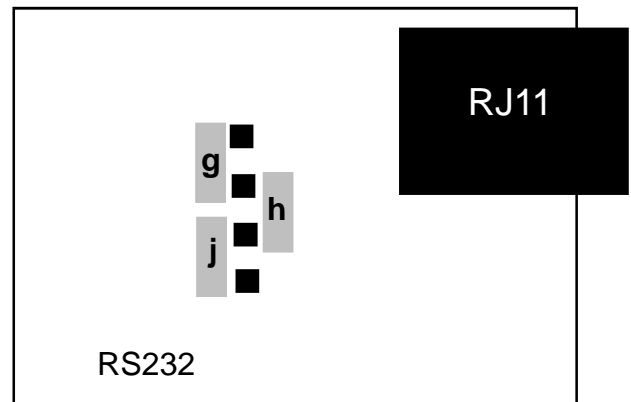

RS485 and Modbus Interface

Full Duplex

Jumpers b and e - These bias jumpers should be installed on 1 (and only 1) meter

Jumpers a and d - are installed on last meter in line with long cable runs

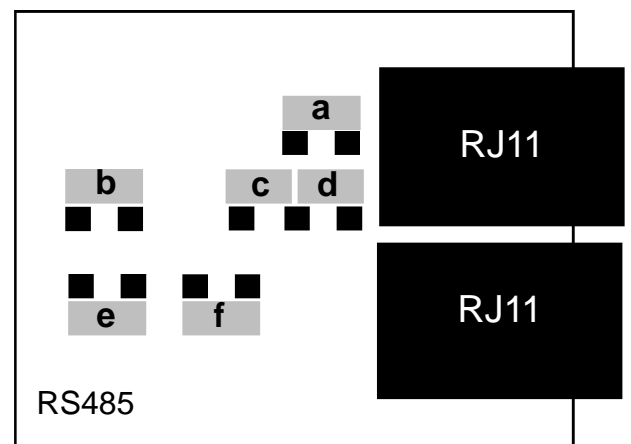

Half Duplex

Jumpers b and e - installed in only 1 meter

Jumpers c and f - installed for half duplex operation

Jumper a - is installed on last meter in line with long cable runs

Note: The board is shipped standard with no jumpers installed

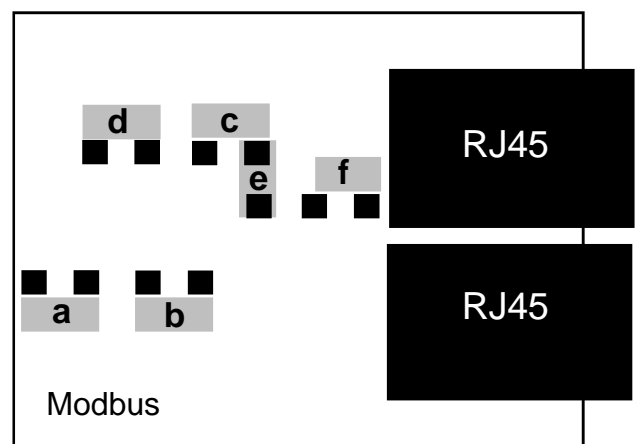

20.

5, 10 AND 24 VDC EXCITATION OUTPUTS

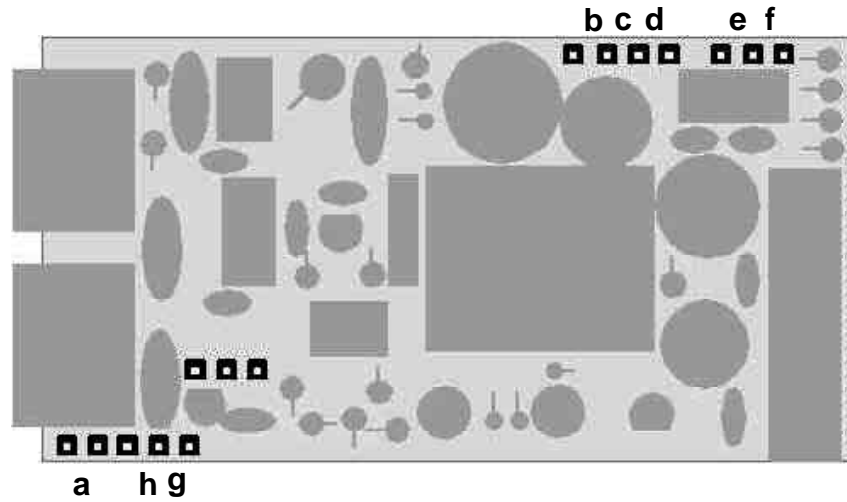
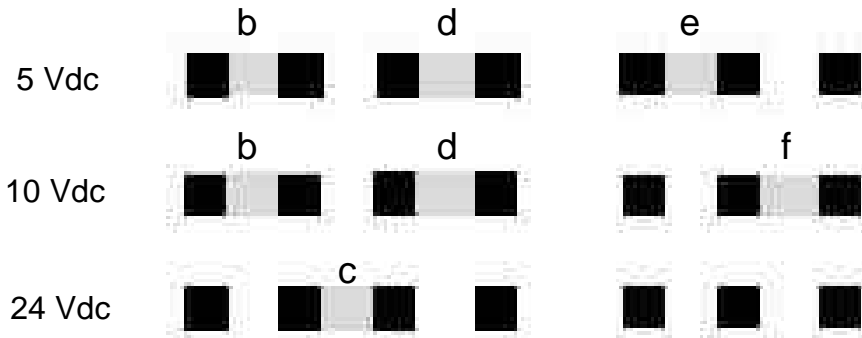

Figure 21. 1 - Power Supply

20.1 SELECTION OF 5, 10 OR 24VDC OUTPUT

Voltage Output	Jumper Locations
5 Vdc	b, d and e
10 Vdc	b, d and f
24 Vdc	c



20.2 SELECTION OF OTHER JUMPERS

- Jumper ' a ' - Front panel menu lockout, locked when installed (see Section 10.1)
- Jumper ' g ' - Provides +5V power output at P1-4 when installed
- Jumper ' h ' - Connects "Digital Input B" to P1-4 when installed

21.

DIGITAL CONTROL INPUTS

21.1 FUNCTION OF DIGITAL INPUTS

Tare Logical 0 - The present display value is set to zero and stored as an offset value.
 Logical 1 - The displayed value is equal to the signal input minus the tare value.

Peak Display Logical 0 - The peak value of the input signal is displayed.
 Logical 1 - The present value of the input signal is displayed.

Hold Logical 0 - The meter display and outputs are held at the last reading.
 Logical 1 - The display and outputs are updated normally

Reset Logical 0 - The microcomputer reads and resets the meter to nonvolatile memory values
 Logical 1 - The meter display and outputs operate normally.

Function Reset Logical 0 - The microC resets peak to present value and resets alarms.
 Logical 1 - The meter display and outputs operate normally.

External Decimal Points	Digital Input A	Digital Input B	Decimal Pts 1	Decimal Pts 2
	1	1	XXXXX	XXXX.X
	0	1	XXXX.X	XXX.XX
	1	0	XXX.XX	XX.XXX
	0	0	XX.XXX	X.XXXX

21.2 MENU SELECTIONS

MENU KEY	DIGIT SELECT KEY	VALUE SELECT KEY
Press the key until SEtup (Basic meter setup) is displayed.	Press to display status. Press again to select digit. Selected digit will flash. Digit 5: digital inputs A & B are located at J1, pins 4 & 5.	Press to select value for flashing digit 0 A: Reset B: Hold 1 A: Func. Reset B: Peak *2 A: Meter Hold B: Peak *3 A: Meter Hold B: Tare *4 A: Peak B: Tare 5 A: Tare B: Reset 6 External Decimal, DP1 7 External Decimal, DP2
* Selections 2, 3, and 4: With A & B both low (grounded), the meter will Function Reset.		

22.

MECHANICAL ASSEMBLY, MICRO-P & MIGHTY-1

22.1 REMOVING THE REAR PANEL

To remove the rear panel, first remove any connectors that are installed. Micro-P: Press down on both rear panel retaining tab releases (see Fig. 23.1) and pull the top of the rear panel away from the case. The bottom of the rear panel will now lift out. Mighty-1: Remove the 6 screws holding the back plate in place and pull the rear panel away from the case.

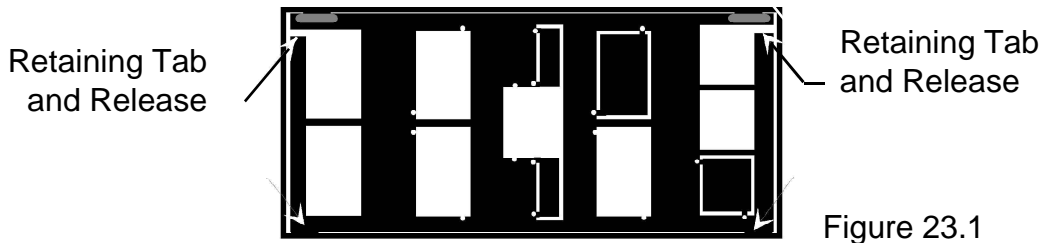

22.2 Removing the meter from the case

After removing the rear panel, the meter can be taken out of the case by carefully grasping the power supply board and signal conditioner board at the connectors and sliding the unit out the back of the case. See Figure 23.2.

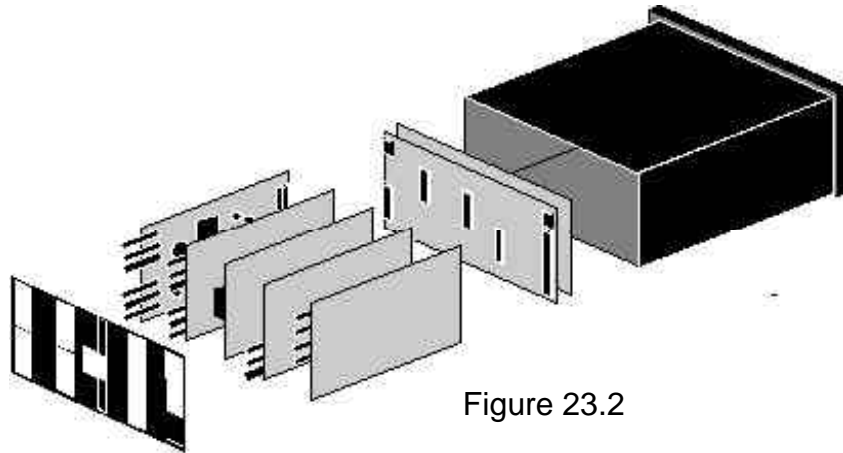

22.3 REASSEMBLING THE METER

Reverse the preceding procedures to reinstall the meter in the case. Micro-P: After the meter is in the case, insert the bottom tabs on the rear panel into the case first. Mighty-1: Replace the rear panel with the 6 screws. For both meters, care must be taken to ensure the printed circuit boards are properly aligned by the board retaining pins on the inside of the rear panel.

23.

MOUNTING AND DIMENSIONS, MICRO-P & MIGHTY-1

Be sure the gasket to mount the case to the panel is in place. Micro-P: Turn the two mounting screws counterclockwise until the space between the mounting pawl and the bezel is greater than the panel thickness. Insert the meter in the panel cutout. Turn the mounting screws clockwise until the meter is securely mounted in the panel. Do not overtighten the mounting screws. Mighty-1: Facing the rear of the meter and using a small hex-key wrench, remove the two set-screws that hold the slides on the sides of the meter. Insert the meter into the panel cutout, install the two slides and set-screws and tighten the set-screws to retain the meter in the panel.

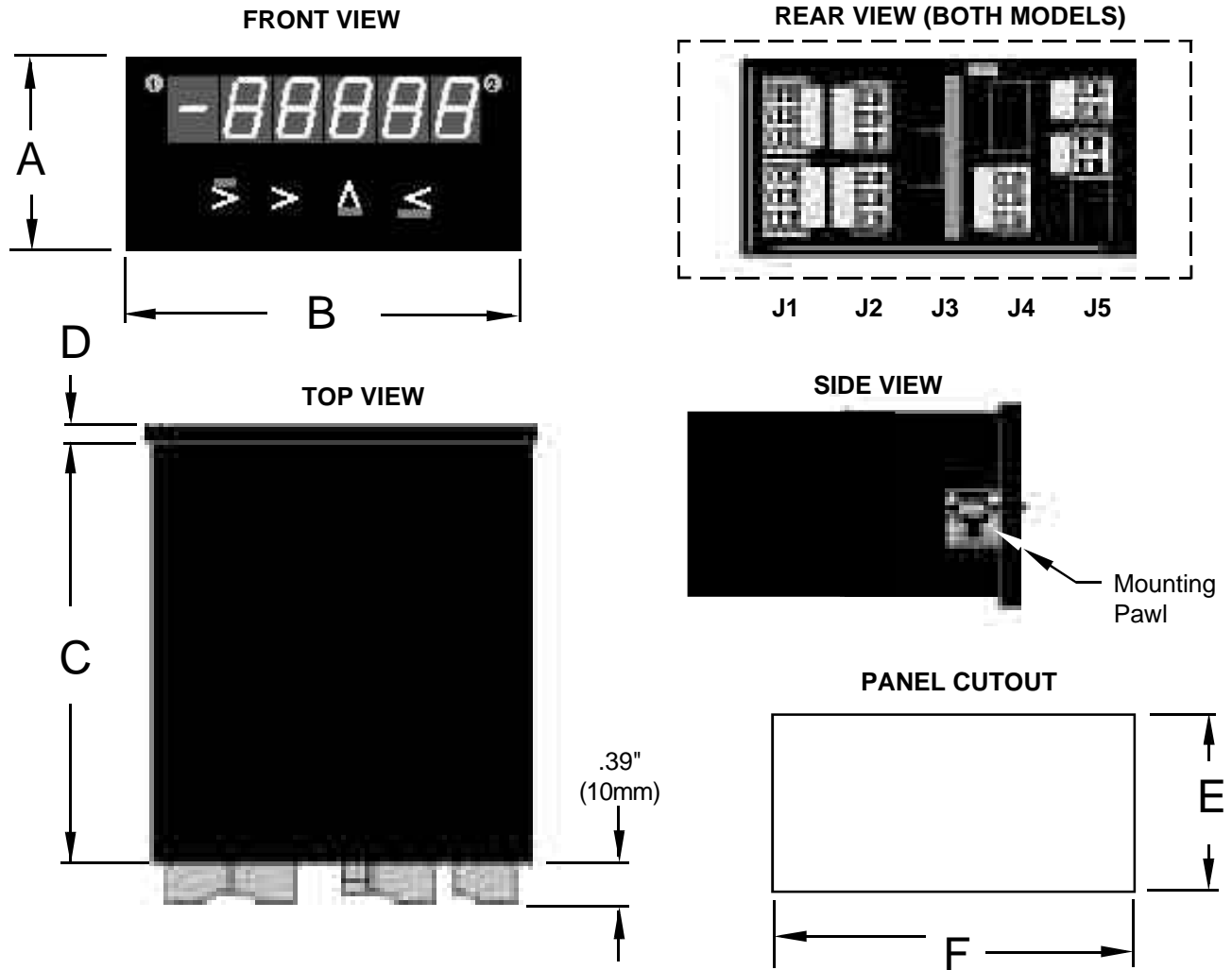

	MICRO-P	MIGHTY-1
A	1.89" (48mm)	3.75" (95mm)
B	3.78" (96mm)	7.5" (191mm)
C	4.02" (102mm)	4.25" (108mm)
D	.197" (5mm)	.50" (13mm)
E	1.772" +.024/-0.0" (92 +0.8/-0.0mm)	3.56" +.03/-0.0" 90.5 +0.7/-0.0mm
F	3.622" +.032/-0.0" (92 +0.8/-0.0mm)	7.20" +.03/-0.0" 183 +0.7/-0.0mm

24.

MIGHTY-5 POWER SUPPLY

The Mighty-5 uses a switching power supply that operates from 85 to 264 Vac or 90 to 370 Vdc. See the diagram below when connecting power. This power supply is in addition to and works in conjunction with the J1 power supply shown in Section 21.

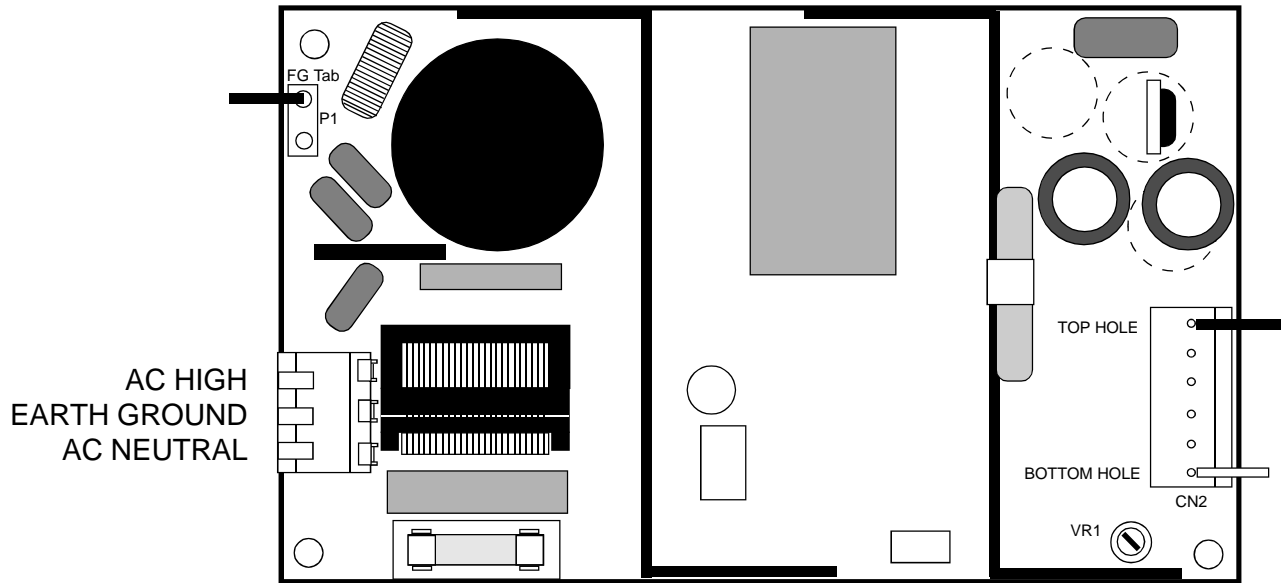

Signal Input and Excitation Outputs are connected to the Mighty-5 at J5. See Section 4 for connections.

Selection of Excitation Output 5V, 10V or 24V and the Menu Lockout are accomplished by jumpers on the J1 power supply. See Section 21. Unless specified at time of order, the Mighty-5 is shipped with 10Vdc Excitation Output selected.

25.

MECHANICAL ASSEMBLY, MIGHTY- 5

NOTE: To make setup changes to the display using the display board mounted pushbuttons, (see Section 5) it is necessary to remove the display board assembly from the case.

25.1 OPENING THE CASE

To remove the display board assembly from the case, loosen the outside nut on the cable feed-through located on the end of the case so the cable is free to move. Remove the (16) rear panel screws from the rear of the case. Remove the rear panel. Using a 3/8" nut-driver, remove the (16) hex nuts holding the display assembly to the window studs. The display board assembly may now be removed from the main portion of the case.

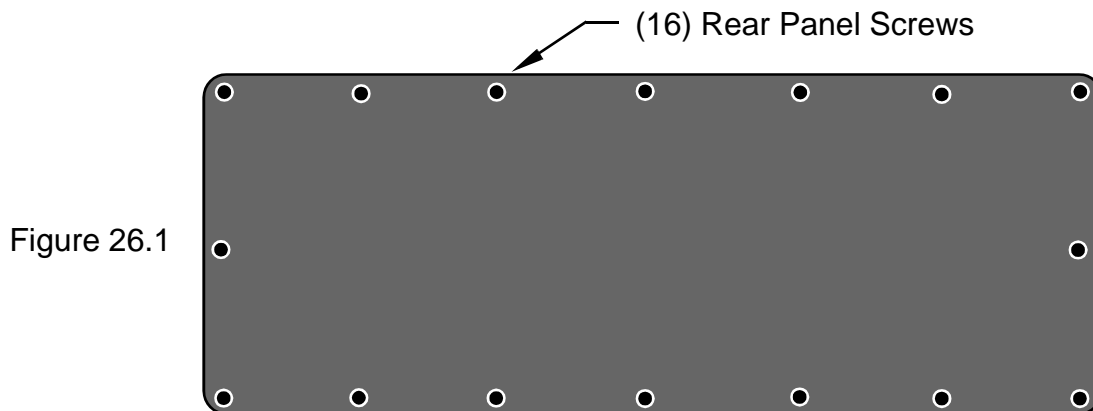

25.2 ACCESSING THE WIRING CONNECTORS

After removing the display board assembly, all plug-in boards and their wiring connectors are accessible. Boards may be added or deleted by first removing the plug-in wiring connectors and then the (4) screws securing the module hold-down board. See Figure 26.2.

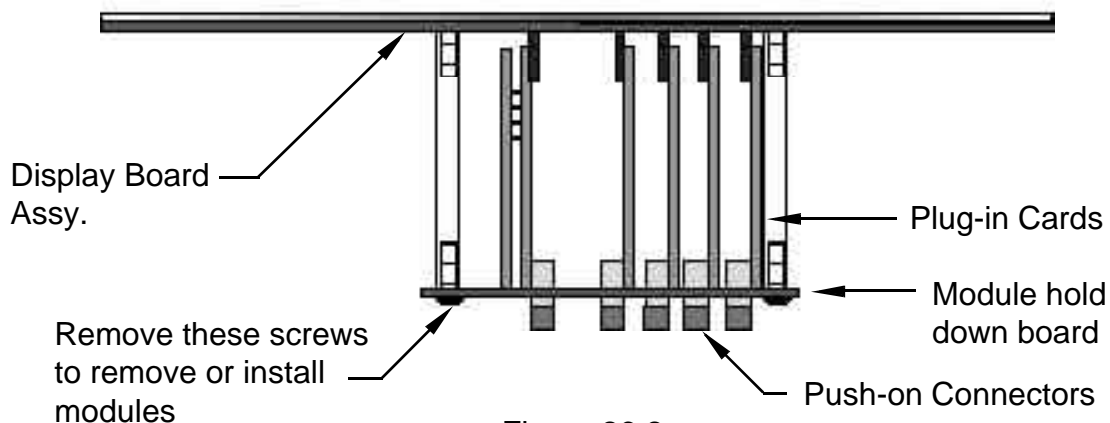

26.3 REASSEMBLING THE DISPLAY

Reverse the preceding procedures to reassemble the case. First install the display board assembly and the (16) hex nuts, do not over-tighten. Next, using the (16) rear panel screws, install the rear panel being careful that the gasket remains in place.

26.

MOUNTING AND DIMENSIONS, MIGHTY-5

If the Mighty-5 display was ordered with rear panel mounting ("W" wall-mount option), the mounting holes in the rear panel may be used to mount the display to a wall or panel. If optional mounting brackets were ordered ("B" bracket-mount option), they may be used to adjust the viewing angle of the display when mounted to a wall or ceiling.

MIGHTY-5

Option 1: Surface Mount Back Panel

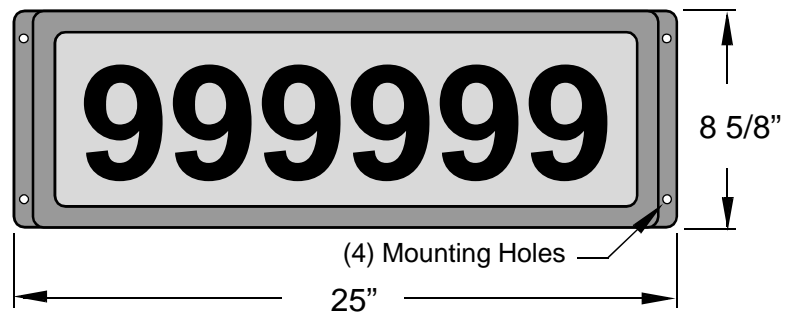

Option 2: Universal Mounting Brackets

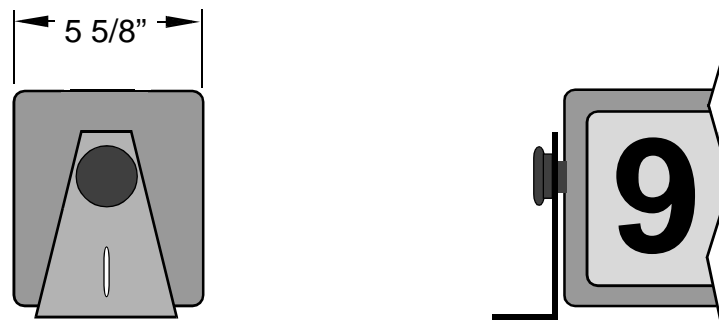

27.

CONNECTORS, ALL MODELS

The Micro Series displays use UL/VDE rated screw terminal connectors that plug into mating jacks on the plug-in modules.

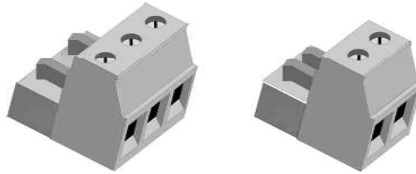

28.

CALIBRATION

All ranges of the displays have been digitally calibrated at the factory and are stored in non-volatile memory. This provides superior long term accuracy and stability while eliminating much of the analog circuitry that causes drift. The calibration equipment is certified to NIST standards. Since the calibration is stored on the signal conditioner and analog output boards, all boards (within the same date-code series) may be mixed and interchanged without requiring recalibration. If recalibration is required, the meter may be returned to Electro-Numerics or any authorized Electro-Numerics distributor.

29.

SPECIFICATIONS

BASIC METER

Display

Type (Micro-P)	5 LED digits, 7-segment, 14 mm (.56") high digits & 2 LED indicators
Type (Mighty-1)	5 LED digits, 7-segment, 25 mm (1.0") high digits & 2 LED indicators
Type (Mighty-5)	5 outdoor LED digits, 7 segment, 127mm (5.0") high & 2 LED Indicators
Color	Red on Mighty-1 & Mighty-5, Green or Red on Micro-P
Range	-99999 to +99999 and -99990 to +99990

A to D Conversion

Rate	60/s for 60 Hz NMR, 50/s for 50 Hz NMR
Output Update Rate	56/s at 60 Hz, 47/s at 50 Hz
Display Update Rate	3.5/s at 60 Hz, 3/s at 50 Hz

Noise Rejection

CMV from DC to 60 Hz	Safety-rated to 250Vac, 4.2kVp per High Voltage Test
CMR from DC to 60 Hz	130 dB
NMR at 50/60 Hz	90 dB with minimum digital filtering

External Inputs/Outputs (CMOS/TTL Levels)

<u>Hold</u> input	0 - holds display and outputs
<u>Peak</u> input	0 - displays peak value
<u>Tare</u> input	0 - offsets input value to zero
<u>Reset</u> input	0 - resets all meter functions
<u>Function Reset</u> input	0 - resets peak values and alarms

ACCURACY

DC Volts

VOLTAGE RANGE	RESOLUTION	INPUT OHMS	ERROR AT 25°C
200.00 mV	10 μ V	1 G	.01% Full Scale +/-2 Ct.
2.0000 V	100 μ V	1 G	
20.000 V	1 mV	1 M	
200.00 V	10 mV	1 M	
660.0 V	100 mV	1 M	

DC Amperes

CURRENT RANGE	RESOLUTION	INPUT OHMS	ERROR AT 25°C
2.0000 mA	0.1 μ A	100	.01% Full Scale +/-2 Ct.
20.000 mA	1.0 μ A	10	
200.00 mA	10 μ A	1	
5.000 A	1.0 mA	.01	

Ratio

VOLTAGE RANGE	RESOLUTION	INPUT OHMS	ERROR AT 25°C
200.00 mV	10 μ V	1 G	.01% Full Scale +/-2 Ct.
2.0000 V	100 μ V	1 G	
20.000 V	1 mV	1 M	

True RMS Volts (1 to 100% Full Scale)

VOLTAGE RANGE	RESOLUTION	INPUT OHMS	ERROR AT 25°C
200.00 mV	10 μ V	22 M	.1% FS +/-10 Ct. from 10 Hz to 10kHz
2.0000 V	100 μ V	22M	
20.000 V	1 mV	1 M	
200.00 V	10 mV	1 M	
660.0 V	100 mV	1 M	

True RMS Amperes (1 to 100% Full Scale)

CURRENT RANGE	RESOLUTION	INPUT OHMS	ERROR AT 25°C
2.0000 mA	0.1 μ A	100	.1% FS +/-10 Ct. from 10 Hz to 10kHz
20.000 mA	1.0 μ A	10	
200.00 mA	10 μ A	1	
5.000A	.25 mA	.01	

RTD's (0.01, 0.1 or 1.0 Degree Resolution)

PT100 TYPE	RANGE	ERROR AT 25°C
DIN .00385	-202°C to +850°C -331°F to +1562°F	.01% FS +/- 0.03°C .01% FS +/- 0.05°F
ANSI .003925	-202°C to +631°C -331°F to +1168°F	.01% FS +/- 0.04°C .01% FS +/- 0.07°F

Thermocouple

(0.1 or 1.0 Degree Resolution)

TC TYPE	RANGE	ERROR AT 25°C
J	-210°C to +760°C -347°F to +1400°F	.01% FS +/- 0.09°C .01% FS +/- 0.16°F
K	-244°C to +1372°C -408°F to +2501°F	.01% FS +/- 0.1°C .01% FS +/- 0.17°F
T	0°C to +400°C -257°C to 0°C +32°F to 752°F -430°F to +32°F	.01% FS +/- 0.03°C .01% FS +/- 0.2°C .01% FS +/- 0.05°F .01% FS +/- 0.36°F
E	-240°C to +1000°C -400°F to +1830°F	.01% FS +/- 0.18°C .01% FS +/- 0.32°F
N	-244°C to +1372°C -408°F to +2501°F	.01% FS +/- 0.1°C .01% FS +/- 0.17°F
S	-46°C to +1768°C -51°F to +3213°F	.01% FS +/- 0.12°C .01% FS +/- 0.22°F
R	-45°C to +1768°C -49°F to +3214°F	.01% FS +/- 0.17°C .01% FS +/- 0.31°F

Load Cell Inputs

INPUT RANGE	RESOLUTION	OUTPUT ZERO RANGE	OUTPUT SPAN RANGE	ERROR AT 25°C
20.000 mV	1 μ V	-99,999 to +99,999	0 to +/-99,999	.01% Full Scale +/-1Ct.
50.000 mV	2.5 μ V			
100.00 mV	5 μ V			
250.00 mV	12.5 μ V			
500.00 mV	25 μ V			

Span Tempco	0.003% of reading/°C
Load Cell Meter only	0.0015% of reading/°C
Zero Tempco	0.2 μ V/°C
Reference Junction	0.03 degree/degree

POWER SUPPLIES

Input Voltage (standard)	85 to 264 Vac, 90 to 370 Vdc
Input Voltage (optional except Mighty-5)	8 to 28 Vac, 9 to 37 Vdc
Frequency	DC and 47 to 440 Hz
Power Consumption	6 Watts max. (Micro-P, Mighty1), 28 Watts max. (Mighty-5)
Excitation Power Supplies	
Outputs	5 Vdc, 5%, 100 mA max 10 Vdc, 5%, 120 mA max. 24 Vdc, 5%, 40 mA max.
Ripple	100 mVp max.
Isolation	Safety-rated to 250 Vac, 4.2 kVp per High Voltage Test

DUAL CONTROLLER OPTION

Basic

Power	Provided by basic meter
Update Rate	56/s at 60 Hz, 47/s at 50 Hz
Setup	Setpoint values may be entered by front panel pushbuttons or via RS-232 or RS485
Lockouts	Front panel pushbuttons control display and change of setpoints, only control display of setpoints, or are disabled
Output Operation	Either output may be set to operate above, below or around the setpoint, latching or non-latching, or output disabled
Filtering	Comparison to the setpoints may be either from the filtered or unfiltered input signal
Time Delay	Selectable time delay of output status change of 1 to 128 readings
Hysteresis	Selectable from 0 to +/- 99,999 counts

Alarm Status Indicators

Type	2 red LED lamps
------------	-----------------

Relay Output

Contact Rating	8A @ 240 Vac, 8A @ 24 Vdc
----------------------	---------------------------

Safety Certifications, Micro-P only	
---	---

Isolation

Coil to Contacts Safety-rated to 250Vac, 4.2kVp per High Voltage Test
Between Open Contacts withstand 4.2kVp for 1 min
Pickup 26 ms typ.
Release 22 ms typ.

Solid State Relay Output

Voltage Rating 125 Vac, 150 Vdc max.
Current Rating 120 mAac, 240 mAdc
Safety Certification VDE, UL and CSA
Isolation Safety-rated to 250 Vac, 4.2 kVp per High Voltage Test
Response to input signal 17 ms typ.

ANALOG OUTPUT OPTION

Isolation Safety-rated to 250 Vac, 4.2 kVp per High Voltage Test
Power Supplied by basic meter
Accuracy Basic meter +/-0.1% of analog full scale
Response Time 17 ms for unfiltered input, same as basic meter for filtered input
Compliance
 0 to 20 mA 12 V (0 to 600 Ohms)
 0 to 10 V 2 mA (5 kOhms min.) load
Scalable Reading for Zero Output -99,999 to +99,999
Scalable Reading for Full Scale Output -99,999 to +99,999

SERIAL INTERFACE OPTION (RS232, RS485, RS485-Modbus boards)

Isolation Safety-rated to 250 Vac, 4.2 kVp per High Voltage Test
Power Supplied by meter
Baud Rates 300, 600, 1200, 2400, 4800, 9600, 19200
RS-485 Wiring Full or half duplex
Signal Levels Meet RS-232 or RS-485 standards
Serial Protocols Custom ASCII*, Modbus* RTU, Modbus* ASCII (selectable)
Connectors.....Single RJ11 (RS232), two RJ11 (RS485), two RJ45 (RS485-Modbus)

ENVIRONMENTAL

Operating Temperature 0°C to 55°C
Storage Temperature -40°C to 85°C

Electro-Numerics family of Digital Panel Meters and Large Digit Indicators are high quality, accurate, solid state instruments designed for years of trouble free operation. Over 30 years of digital instrumentation experience has resulted in a series of displays recognized in the field as reliable, well designed instruments. From our compact sized DPM's with 0.56" LED digits to our Large Digit Indicators with 1", 2 1/4" & 5" LEDs or 6" & 9" tall electromagnetic digits, we cover most applications in process measurement and display. For full product information and prices, visit our web site at **www.ElectroNumerics.com**.

Warranty (2 Years)

Electro-Numerics, Inc. warrants these products to be free in defects in workmanship and materials for two years from the date of shipment to the original customer. This warranty on workmanship and materials may be considered as unconditional provided that, in the opinion of Electro-Numerics, Inc., the equipment has not been mechanically, environmentally, or electrically abused and has been installed, maintained and operated within the limits of rated or normal usage.

Defective products must be sent, transportation charges prepaid with notice of the defect, to our plant in Temecula, CA.

This warranty is limited, at the option of Electro-Numerics, Inc., to repair, replacement, or an appropriate credit adjustment not to exceed the original equipment sales price. All warranty freight charges are F.O.B. our plant, Temecula, CA.

Electro-Numerics, Inc. assumes no responsibility in connection with the sale of its products beyond that stated above and is not responsible for any incidental or consequential loss or damage which might result from a failure of any Electro-Numerics, Inc. product.

Repair Policy

Direct all warranty and out-of-warranty requests/inquiries to Electro-Numerics, Inc., Customer Service Repair Dept., telephone: 800-854-8530 (U.S.A.) or 951-699-2437, Fax: 951-695-7246, Email: Sales@ElectroNumerics.com. Repair work will be handled at the factory or an authorized Electro-Numerics, Inc. repair service center.

All items sent in for service are subject to a minimum evaluation charge of \$65.00 in the event that the product is found to be out-of-warranty or, if under warranty, not in need of additional service. Out-of-warranty service and repair charges will be quoted on a case by case basis. All repaired products will be shipped to you F.O.B., Temecula, CA.

There are three methods of scaling the meter. Method 1 reads the values when the meter is connected to a sensor or transducer. Method 2 uses Scale Factor and Offset ($MX + b$), see SCALE and OFFSET below. Method 3 uses Coordinate of Two Points. Methods 2 and 3 do not require that the meter be connected to a sensor or transducer and the scaling information is usually supplied from the sensor's calibration certificate.

Coordinates of Two Points With this method of scaling (Method 3), you enter known values for zero and full scale. For example if the meter is connected to a 4/20mA pressure sensor for a reading of 0 to 100.0 PSI, you would input 4mA = 000.0 and 20 mA = 100.0.

Note: Method 2 (Scale Factor and Offset) is the default method of scaling shipped from the factory.

Scale With this method of scaling (Method 2), you enter calculated values for Scale (scale factor) and Offset (at zero). The scale factor may be set from +/- -0.0001 to +/-9.9999. When scale is selected, the most significant digit flashes allowing the value of that digit to change, pushing the digit select key moves the flashing digit to the right. When the right hand digit is flashing, pushing the digit select key again causes the decimal point to be displayed. Pushing the value select key changes the location of the decimal point. When decimal XXXXX. is reached, the next time the digit select key is depressed, the display goes back to the scale factor.

Offset Offset is used in conjunction with Scale above. An offset value from -99,999 to 99,999 may be entered in the offset menu item to be used to offset the zero point.

Deviation Applies to Setpoint Alarms. Either alarm may operate in the deviation mode. In the menu item "dEU1b & dEU2b", a value is entered equivalent to the amount above and below the setpoint at which the alarm operates. For example, if the value entered is 100, and the setpoint value is 1000, the alarm would energize above 1100 and below 900.

Hysteresis Applies to Setpoint Alarms. Either alarm may operate in the hysteresis mode. In the menu item "dEU1H & dEU2H", a value is entered equivalent to the amount above and below the setpoint at which the alarm operates. For example, if the value entered is 10, and the setpoint value is 1000, if the alarm is set to energize above the setpoint, the alarm would energize above 1010 would not deenergize until the displayed value goes below 990. This mode reduces relay chatter and excessive cycling of the load.

Auto filtering This filtering method looks at the input signal for +/- variations. The larger the deviations, the greater the filtering applied. The amount of filtering is automatic and based on the moving average chart following.

Auto Filtering Continued:

TIME	READINGS AVERAGED
0.08 sec	2
0.15 sec	4
0.30 sec	8
0.60 sec	16
1.20 sec	32
2.40 sec	64
4.80 sec	128
9.60 sec	256

- Batch averaging, 16 rdgs.** There are two BATCH AVERAGING listings, one under DISPLAY FILTERING and the other under INPUT SIGNAL FILTERING. They both operate in the same manner however the one for DISPLAY FILTERING pertains only to the display while the other operates on all other functions listed as filtering either on or off, such as the analog output and peak signal. The meter accumulates 16 readings, averages them and displays the results or sends the results to the output board. When finished, the result is cleared and the process begins again with another 16 readings. There is no moving averaging associated with this type of filtering.
- Moving average** Assume the INPUT SIGNAL FILTERING is set to 4. This relates to a moving average of 8 readings. The meter will take 1/8 of the new reading and add it to the previous moving average, then average it again which becomes the new moving average. This process continues until the MOVING AVERAGE selection is changed.
- Unfiltered input** When unfiltered is selected, the meter will process information at approximately 56 readings per second. If filtering is selected, the processing rate will be slower than 56 readings per second dependent on the amount of filtering used.
- Calibration** CALIBRATION should not be confused with the term SCALING. CALIBRATION of the meter is done at the factory where calibration values are entered into memory locations to compensate for factors such as component tolerance, etc. This provides superior long term accuracy and stability while eliminating much of the analog circuitry that causes drift. To perform CALIBRATION requires factory equipment and software. See SCALING.
- Scaling** Scaling of the meter can be accomplished by the user with or without sophisticated laboratory standards. Scaling uses the meter's menu that allows setting of all parameters such as zero offset, full scale readings, analog output values, etc. In other words all of the parameters of the meter are accessible to the user to make the meter function in the manner required. These functions are listed under SETUP, Section 9 of this manual.



ELECTRO-NUMERICS, INC

42213 Sarah Way, Temecula CA 92590

Tel (U.S.A.): **800-854-8530** or 951-699-2437

Fax: 951-695-7246

Email: Sales@ElectroNumerics.com, Internet: www.ElectroNumerics.com