

**MICRO-P
MIGHTY-1
MIGHTY-4
MIGHTY-5
OWNERS MANUAL**



ELECTRO-NUMERICS, INC.

CONTENTS

SECTION NO:	PAGE NO:
1. INTRODUCTION	1
2. RECEIVING AND UNPACKING	2
3. SAFETY CONSIDERATIONS	2
4. CONNECTOR WIRING INFORMATION	3
5. FRONT PANEL CONFIGURATIONS.....	5
6. METER KEYPAD FUNCTIONS	5
7. SCALING METHODS	7
8. SETTING MENU LOCKOUTS	8
9. METER SETUP AND PROGRAMMING	10
10. DC VOLTS & AMPS	20
11. PROCESS SIGNAL INPUTS	22
12. THERMOCOUPLES	24
13. PT100 RTD'S	26
14. STRAIN GAUGES AND POTENTIOMETERS	28
15. AC (RMS) VOLTS & AMPS	30
16. LOAD CELLS AND MICROVOLT INPUTS	32
17. DUAL SETPOINT CONTROLLER	34
18. ANALOG OUTPUT	36
19. RS-232 AND RS-485 INTERFACE	37
20. PARALLEL BCD OUTPUT	38
21. 5, 10 AND 24 VDC EXCITATION OUTPUTS.....	39
22. DIGITAL CONTROL INPUTS	41
23. MECHANICAL ASSEMBLY, MICRO-P & MIGHTY-1	42
24. MOUNTING AND DIMENSIONS, MICRO-P & MIGHTY-1	43
25. MECHANICAL ASSEMBLY, MIGHTY-4	44
26. MECHANICAL ASSEMBLY, MIGHTY-5	45
27. MOUNTING AND DIMENSIONS, MIGHTY-4 & MIGHTY-5	46
28. CONNECTORS, (All Models)	47
29. CALIBRATION (Also See "SCALING", Section 32)	47
30. SPECIFICATIONS	47
31. WARRANTY & REPAIR POLICY	51
32. GLOSSARY OF TERMS	52

1.

INTRODUCTION

The Micro Series meters, which include models Micro-P, Mighty-1, Mighty-4 and Mighty-5, are versatile, cost effective solutions to a wide variety of monitoring and control applications. These instruments are easily set to produce an accurate display of temperature, pressure, flow, weight, voltage or current. Front panel push-button or RS-232/RS-485 setup allows the user to customize the unit for a specific application. Digital scaling of zero and span provides direct readout in engineering units. Digital calibration of all ranges eliminates drift associated with potentiometers found in non-microcomputer-based meters. These meters utilize a unique method of analog-to-digital conversion that provides 60 conversions per second (50 for 50 Hz operation) while integrating over a full cycle of the line for maximum noise rejection. Self calibration cycles reduce the average reading rate to 56 per second (47 for 50 Hz). This fast read rate provides an accurate display of peak signal input and quick response in control applications. The adaptive auto filter automatically supplies a time constant compatible with the signal noise level. This ensures stable displayed readings and outputs while responding rapidly to changes of the input signal that exceed a selected threshold value. Selective security lockout of the front panel setup protects against accidental changes to the meter configuration and simplifies use by the operator. These meters use a lightweight, high-efficiency switching power supply that operates from either AC or DC voltages and complies with safety regulations. The meter can be powered worldwide without changes to the supply. An optional low voltage supply (optional on all models except Mighty-5) operates on 9 to 37 Vdc from batteries or 8 to 28 Vac from sources such as 400 Hz aircraft power. Both supplies have isolated 5 Vdc, 10 Vdc and 24 Vdc excitation supplies to power transducers. All wiring is by removable plugs conforming to IEC950 safety standards. All output options are isolated from meter and power ground by 250 Vac minimum. Enclosures for models Micro-P, Mighty-1 are designed for indoor panel mounting. Model Mighty-4 may be panel or surface mounted and model Migthy-5 features a NEMA-4X case for outdoor mounting.

The dual setpoints have two form C (10 A @ 250 Vac) relays or solid state relay outputs for alarm and control capabilities. Either setpoint may be latching or nonlatching and may be separately configured to be energized above or below the setpoint or in a fail-safe mode. Outputs may also be selected to operate from the filtered signal to reduce relay chatter or from the unfiltered signal for fast response. Snubber circuits and programmable relay switching time delay extend relay contact life.

Isolation of the 0 to 20 mA (4/20 mA) and 0 to +10 V analog outputs eliminate ground loop problems. The output may be scaled by front panel push-buttons or RS-232/RS-485. For thermocouples and RTD's, the output is linearized. Depending on the application, the analog output may be selected to operate from the filtered or unfiltered signal input. The 0 to 20 mA (4/20 mA) output will drive up to an 600 Ohm load with 12 V compliance

This series offer RS-232 or RS-485 bidirectional communications or parallel, 3-state BCD output to interface with computers, PLC's or other digital devices. IBM PC compatible software is available from Electro-Numerics for programming of the unit by the RS-232 and RS-485 interfaces.

2.

RECEIVING AND UNPACKING

Your meter has been carefully tested and inspected prior to shipment. Should the meter be damaged in shipment, notify the freight carrier immediately. In the event the meter is not configured as ordered or the unit is inoperable, return the unit to the place of purchase for repair or replacement. Please include a detailed description of the problem.

3.

SAFETY CONSIDERATIONS

Warning  : The use of this equipment in a manner other than specified may impair the protection of the device and subject the user to a hazard. Visually inspect the meter for signs of damage. If the unit is damaged, do not attempt to operate.

This unit will operate from AC power, 85 to 264 Vac (90 to 370 Vdc). All models except the Mighty-5 will also operate on 8 to 28 Vac (9 to 37 Vdc) with the low-range power supply installed. Verify that the proper power option is installed for the power to be used. High range power supplies are identified with MPS1 (Micro-P, Mighty-1 and Mighty-5) or MPS3 (Mighty-4) while low range power supplies are designated MPS2 (Micro-P, Mighty-1) or MPS4 (Mighty-4).

These meters have no AC or DC (mains) switch; they will begin operating as soon as power is connected.

Do not make signal wiring changes or connections when power is applied to the instrument . Make signal connections before power is applied and, if reconnection is required, disconnect the AC or DC (mains) power before such wiring is attempted.

To prevent electrical or fire hazard, do not expose these meters to excessive moisture. When models Micro-P or Mighty-1 are properly installed in a panel with the rubber gasket in place, the meter bezel is sealed against dust and moisture however, the rear of the meter and the connectors are not sealed. Models Mighty-4 & Mighty-5 are supplied in a sealed case, however, it is necessary to use a sealed conduit connector for the power and signal connections to the meter.

Do not operate the instrument in the presence of flammable gases or fumes; such an environment constitutes a definite safety hazard. This meter is designed to be mounted in a metal panel.

Verify the panel cutout dimensions and mount according to instructions.

4.

CONNECTOR WIRING INFORMATION

4.1 CONNECTOR LOCATION

The connectors are screw terminals that plug into the mating jack mounted on the printed circuit board. J3 is either one 6 conductor phone plug for RS-232 or two for RS-485 where the second jack (J3B) is in parallel with J3-A to allow daisy-chaining several meters. J3 can also be a 30 pin, mass termination, edge connector when parallel BCD is installed.

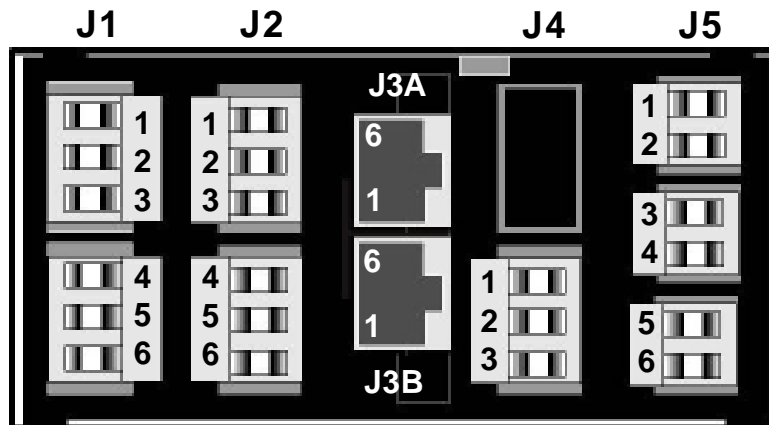

4.2 J1 - POWER AND DIGITAL CONTROLS

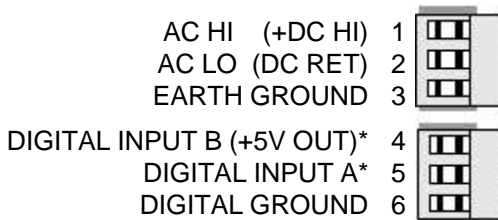

*Note: Non-isolated digital control inputs A and B are menu selectable for Tare, Peak Display, Hold, or Reset and external control of decimal points.

Digital Input B selected - Jumper "h"
+5V Output selected - Jumper "g"

4.3 J5 - SIGNAL INPUT

DC & PROCESS

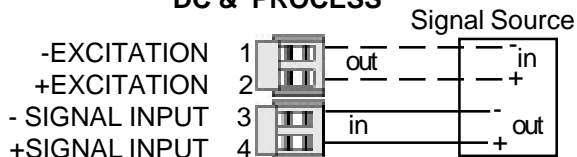

2 WIRE PROCESS TRANSMITTER

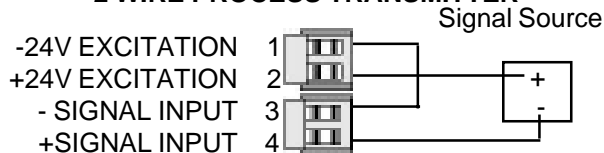

STRAIN GAUGE

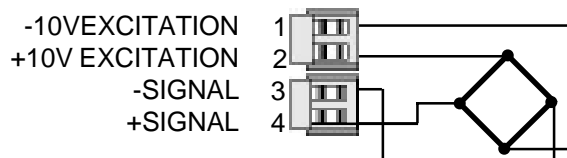

AC (TRUE RMS)

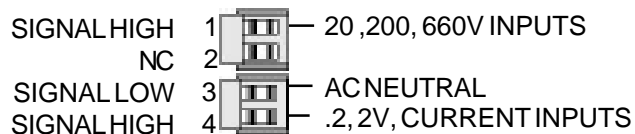

RTD (2-WIRE)

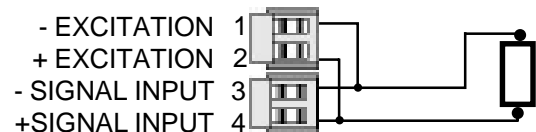

RTD (3-WIRE)

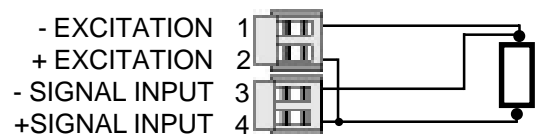

RTD (4-WIRE)

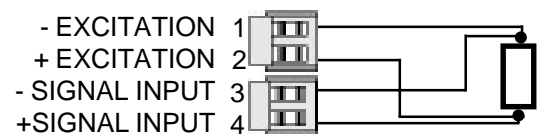

THERMOCOUPLE



4.3 J5 - SIGNAL INPUT (CONTINUED)

LOAD CELL METER

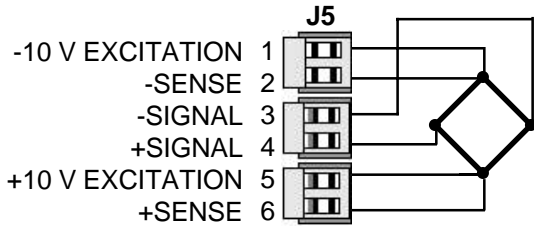

4.4 J4 - ANALOG OUTPUT

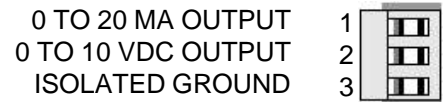

4.5 J 2 - DUAL SETPOINT CONTROLLER

RELAY OUTPUTS

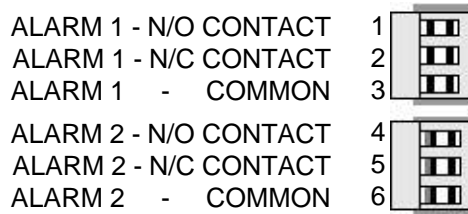

SOLID STATE RELAY OUTPUTS

Switching AC 125Vac @120 ma max.

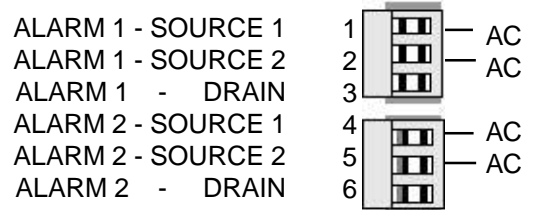

SOLID STATE RELAY OUTPUTS

Switching DC 125Vdc @240 ma max.

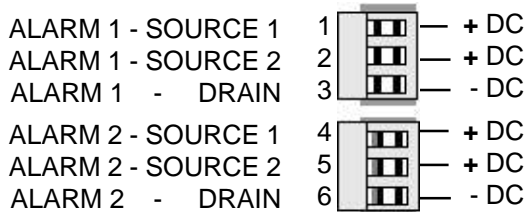

* SOLID STATE RELAY OUTPUTS

Switching DC 125Vdc @120 ma max.

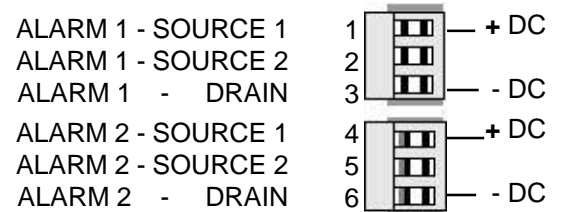

* This configuration is directly compatible with the Open Collector model MOC.

4.6 J3 DIGITAL INTERFACE

RS - 232 INTERFACE

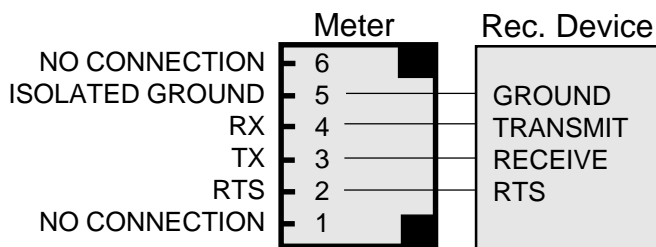

RS - 485 INTERFACE

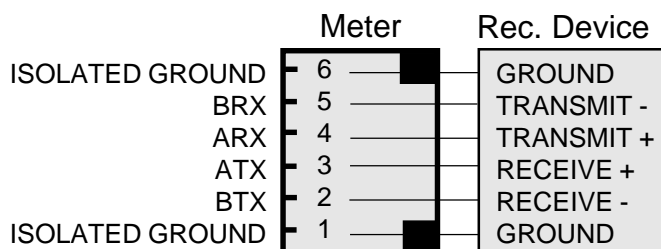

BCD OUTPUT

1	1	2	2
4	3	4	8
10	5	6	20
40	7	8	80
100	9	10	200
400	11	12	800
1K	13	14	2K
4K	15	16	8K
10K	17	18	20K
40K	19	20	80K
100K	21	22	200K
400K	23	24	800K
+ POL	25	26	DATA READY
BCD HOLD	27	28	BCD ENABLE
ISOLATED GND	29	30	ISO 5 / 15VDC

5.

FRONT PANEL CONFIGURATIONS

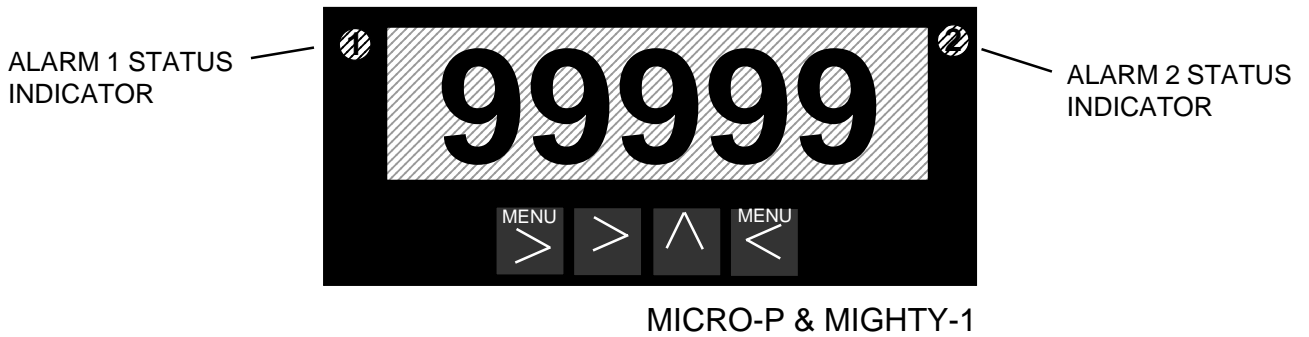

Display board assembly removed from case

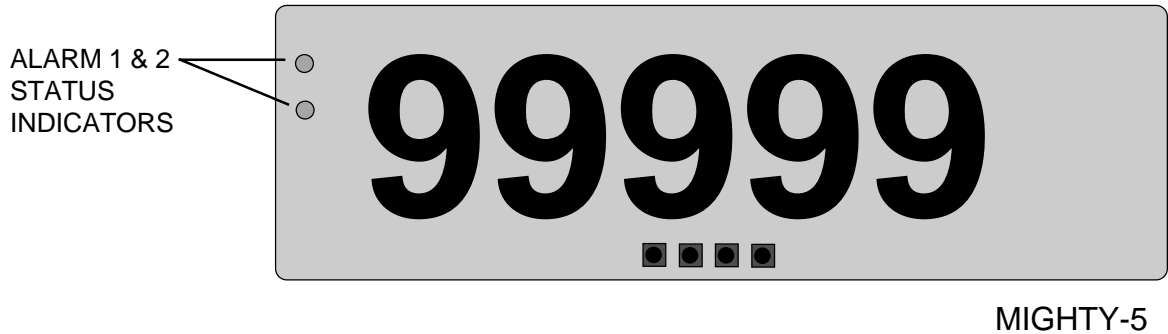

6.0

METER KEY PAD FUNCTIONS

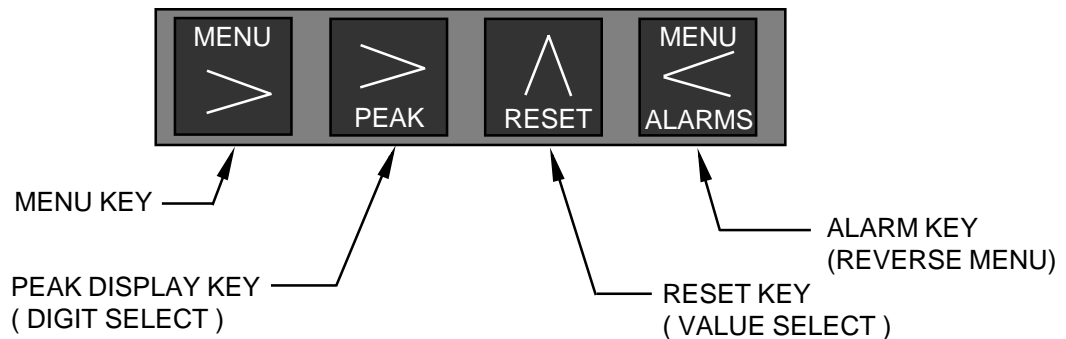

Shown above are the four meter models discussed in this manual. The four keypads on the front of each panel operate in exactly the same way and perform the same functions for all models. The following discussion explains these functions in detail.

MENU KEY FUNCTIONS

Operating Mode

PRESSING



ACTIONS

1. Causes the meter to change from the OPERATING mode to the MENU mode.

Menu Mode

PRESSING



RESULTS

2. Each additional press of the menu key will advance to the next menu item until RESET is reached at which time the meter will reset into the OPERATING mode again.
3. While in the MENU mode, after performing any change, pressing the menu key will store the changes made to the item values.
4. Resets the meter and shifts to the OPERATING mode without having to go to the end of the menu items.



PEAK KEY FUNCTIONS

Menu Mode

PRESSING



RESULTS

1. While the meter is displaying a menu item, pressing the PEAK key will show the values of that menu item. One of the digits displayed will be flashing which indicates its value may be changed. To make any digit active, keep pressing the PEAK key until the digit you wish to change begins to flash.
2. Will increment the flashing digit by one for each press.



Operating Mode



3. Toggles the display between the PEAK, noted by a blinking display, and INPUT values.

RESET KEY FUNCTIONS

Operating Mode

Pressing the RESET key and any other key causes several different resets to take place.

PRESSING

ACTIONS

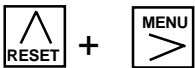

1. Resets all display functions.

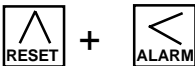

2. Resets any alarm conditions.



3. Resets the peak value to the current peak value.

ALARM KEY FUNCTIONS

Operating Mode

PRESSING

ACTIONS



1. 1st. press displays setpoint #1 value. The value may be changed by using the Digit Select and Value Select Keys.



2. 2nd. press displays setpoint #2 value. The value may be changed by using the Digit Select and Value Select Keys.



3. 3rd. press returns to the input signal value.

Menu Mode



4. Steps the display backwards through the menu items.

7.0

SCALING METHODS

There are three selectable methods for scaling the meter. They apply to all input board types except the THERMOCOUPLE and RTD temperature boards. The three methods are defined below.

1. **Method 1, "Scaling by reading the input signal values":**
When using this method, the meter calculates the proper scaling and offset values, entering them into memory. The meter is connected to your sensor and looks at the values of the input signals.
2. **Method 2, "Scaling using scale and offset" (Factory set default):**
This method requires that you calculate the required scale and offset values and enter them into memory when the meter displays SCALE and OFFSET. The meter does not need to be connected to your sensor.
3. **Method 3, "Scaling using the coordinates of two points":**
In using this method you enter the low input signal value, the display value for the low signal, the high input signal value and the display value for the high input signal. These values are entered when menu items **Lo In**, **Lo rd**, **HI In** and **HI rd** are displayed. The meter does not need to be connected to your sensor.

7.1 Accessing scaling method 1

1. Remove the input board and verify that the jumpers are in the correct positions for the range you intend to use. Re-install the board.
2. Apply power and press the left **MENU** key until **ConFG** appears on the display.
3. Press the **PEAK** key and five digits will appear on the display. Continue pressing the **PEAK** key until the second digit begins to flash **01000**. Make this digit a "1" by pressing the **RESET** key until "1" appears. Note that when this digit is a "0", you have access to scaling methods 2 and 3. Store the change by pressing the left **MENU** key. Go to Section 9 in this manual and perform the procedure "**signal scaling by applying a known pressure or weight**". Perform any other changes in section 9 that are required for your application.

7.2 Accessing scaling method 2

1. Remove the input board and verify that the jumpers are in the correct positions for the range you intend to use. Re-install the board.
2. Apply power and press the left **MENU** key until **ConFG** appears on the display.
3. Press the **PEAK** key, and five digits will appear on the display. Continue pressing the **PEAK** key until the underlined (second) digit begins to flash **00000**. Make this digit a "0" by pressing the **RESET** key until "0" appears. Note that when this digit is a "1", you have access to scaling method 1 only. Store the change by pressing the left **MENU** key.
4. Go to Section 9 under **SEtuP** and select "**Scale Factor and Offset**". Press the **PEAK** key, and five numbers will appear on the display. Press the **PEAK** key again until the underlined (fourth) digit begins to flash **00000**. Make this digit a "0" by Pressing the left **MENU** key. Perform any other changes in Section 9 that are required for your application.

7.3 Accessing scaling method 3

1. Remove the input board and verify that the jumpers are in the correct positions for the range you intend to use. Re-install the board.
2. Apply power and press the left **MENU** key until **ConFG** appears on the display.
3. Press the **PEAK** key, and five digits will appear on the display. Continue pressing the **PEAK** key until the second digit begins to flash **00000**. Make this digit a "0" by pressing the **RESET** key until "0" appears. Note that when this digit is a "1", you have access to scaling method 1 only. Store the change by pressing the left **MENU** key.
4. Go to Section 9 under **SEtuP**. Press the **PEAK** key, and five numbers will appear on the display. Press the **PEAK** key again until the underlined digit begins to flash **00010**. Make this digit a "1" by pressing the **RESET** key until "1" appears. Store the change by pressing the **MENU** key. Referring to Section 9, press left **MENU** until **Lo In** appears. Using the **PEAK** and **RESET** keys, enter the low input value. Push the left **MENU** key until **Lo rd** appears. Using the **PEAK** and **RESET** keys, enter the low reading to be displayed. Repeat this procedure for **HI In** and **HI rd**. Perform any other changes in Section 9 that are required for your application.

8.

SETTING MENU LOCKOUTS

For security and ease of operation, any or all program menu items may be disabled. Each function to be disabled is set to "1" in the menu items, "Loc 1", "Loc 2" or "Loc 3". These lockout menu items may in turn be "locked-out" by installing an internal hardware shorting jumper. With the jumper installed, the operator has access only to enabled menu items.

8.1 SETTING HARDWARE LOCKOUT JUMPER



Lockout Jumper

To access the jumper, disassemble the display (see Sections 23, 25 & 26). Remove jumper "a" located on the lower portion of the power supply board next to the input connectors (see figure at left) to enable the software lockouts. Replace the jumper to disable software lockouts.

















Jumper Removed - Loc 1, 2 and 3 are displayed as menu items and allow other menu items to be locked out or enabled.

Jumper Installed - Loc 1, 2 and 3 are not displayed on program menu

Figure 8.1 Power Supply Board

8.2 SETTING SOFTWARE LOCKOUTS

When setting up the meter, it may be necessary to enable some of the menu items. Any digit set to "1" in Loc 1, Loc 2 or Loc 3 indicates that item is locked out. By setting the digit to "0", the item will appear in the menu. Be sure to reset the lockout bit to "1" after selection if you do not want the value changed by the operator. **Note:** The hardware lockout jumper must be removed to access Loc 1, 2 and 3 (see section 8.1)

MENU KEY 	DIGIT SELECT KEY 	VALUE SELECT KEY 
 Press the  key until Loc 1 is displayed.	 Press  to display status and select left digit. Press  again to select another digit. Selected digit will flash. "1" indicates the menu item is disabled. "0" indicates the item is enabled.	 1 2 3 4 5 Press  to select "0" or "1" for flashing digit 1 - Input type selection 2 - Meter setup & decimal pt. 3 - Filter selection 4 - Scale or Lo, Hi Input 5 - Offset or Lo, Hi Reading
 Press the  key until Loc 2 is displayed.	 Press  to display status and select left digit. Press  again to select another digit. Selected digit will flash. "1" indicates the menu item is disabled. "0" indicates the item is enabled.	 2 3 4 5 Press  to select "0" or "1" for flashing digit 2 - Alarm Setup 3 - Alarm setpoint value programming 4 - Analog output scaling 5 - Serial interface setup



SETTING SOFTWARE LOCKOUTS (CONT.)



Loc 3

Press the  key until Loc 3 is displayed.

1111

Press  display status and select left digit. Press  again to select another digit. Selected digit will flash. "1" indicates the menu item is disabled. "0" indicates the item is enabled.

0000



Press  to select "0" or "1" for flashing digit
 2 - View peak value
 3 - View alarm setpoints
 4 - Reset (peak and latched alarms)
 5 - Reset (meter reset)

9.

METER SETUP & PROGRAMMING

Before beginning Setup of the meter, you should first decide on the method of meter scaling as described on page 7. Method 2 is the default setting shipped from the factory. Scaling method 1 does not apply to thermocouples or RTD's. Starting on page 11, proceed through the Setup menu with **InPut**, **SEtuP** and **ConFG**. Under **ConFG**, if you select **01000** Method 1 (scaling by reading the input signals), and after a meter **ReSet**, you must connect the meter to your sensor or transducer and use the following procedure to scale the meter. If you select **00000** (method 2 or 3) *this procedure does not apply.*



<p>Lo in Low signal input value (not available for tC & rtd)</p>	<p>0.021 Set the input signal to zero or a known low value</p>	<p>0.021 Press the  key to store the low signal input.</p>
<p>Hi In High Signal Input Value</p>	<p>20.094 Set the input signal to a known high value</p>	<p>20.094 Press the  key to store the high signal input.</p>
<p>Lo rd Set Low Displayed Reading for Low Signal Input</p>	<p>0.0000 0.0000 0.0000 0.0000 0.0000 Select digit. Digit will flash</p>	<p>0.000 Select 0 through 9 for flashing digit. Decimal point location is fixed by dEC.Pt.</p>
<p>Hi rd Set High Displayed Reading for High Signal Input</p>	<p>0.0000 0.0000 0.0000 0.0000 0.0000 Select digit. Digit will flash</p>	<p>0.000 Select 0 through 9 for flashing digit. Decimal point location is fixed by dEC.Pt.</p>

MENU KEY 

DIGIT SELECT KEY 

VALUE SELECT KEY 

TEMPERATURE SIGNAL CONDITIONER

<p>InPut Input signal type</p>	<p>tC Thermocouple</p> <p>Note: Display  = K</p>	<table border="1"> <tr> <td>J°F</td> <td>J°C</td> <td>K°F</td> <td>K°C</td> <td>t°F</td> </tr> <tr> <td>t°C</td> <td>E°F</td> <td>E°C</td> <td>S°F</td> <td>S°C</td> </tr> <tr> <td>r°F</td> <td>r°C</td> <td>n°F</td> <td>n°C</td> <td>Types</td> </tr> </table> <p>J, K, T, E, N, S, R in °C or °F</p>	J°F	J°C	K°F	K°C	t°F	t°C	E°F	E°C	S°F	S°C	r°F	r°C	n°F	n°C	Types					
	J°F	J°C	K°F	K°C	t°F																	
t°C	E°F	E°C	S°F	S°C																		
r°F	r°C	n°F	n°C	Types																		
<p>rtd Pt 100 Ohm RTD</p>	<table border="1"> <tr> <td>4d °F</td> <td>4d °C</td> <td>DIN 4-wire</td> </tr> <tr> <td>4A °F</td> <td>4A °C</td> <td>ANSI 4-wire</td> </tr> <tr> <td>3d °F</td> <td>3d °C</td> <td>DIN 3-wire</td> </tr> <tr> <td>3A °F</td> <td>3A °C</td> <td>ANSI 3-wire</td> </tr> <tr> <td>2d °F</td> <td>2d °C</td> <td>DIN 2-wire</td> </tr> <tr> <td>2A °F</td> <td>2A °C</td> <td>ANSI 2-wire</td> </tr> <tr> <td>Short</td> <td colspan="2">Compensation for 2-wire lead resistance</td> </tr> </table>	4d °F	4d °C	DIN 4-wire	4A °F	4A °C	ANSI 4-wire	3d °F	3d °C	DIN 3-wire	3A °F	3A °C	ANSI 3-wire	2d °F	2d °C	DIN 2-wire	2A °F	2A °C	ANSI 2-wire	Short	Compensation for 2-wire lead resistance	
4d °F	4d °C	DIN 4-wire																				
4A °F	4A °C	ANSI 4-wire																				
3d °F	3d °C	DIN 3-wire																				
3A °F	3A °C	ANSI 3-wire																				
2d °F	2d °C	DIN 2-wire																				
2A °F	2A °C	ANSI 2-wire																				
Short	Compensation for 2-wire lead resistance																					

DC SIGNAL CONDITIONER

<p>dC U DC Volts</p>	<table border="1"> <tr> <td>0.2U</td> <td>2.0U</td> <td>20.0U</td> </tr> <tr> <td>200.0U</td> <td>660.0U</td> <td></td> </tr> </table> <p>0.2, 2, 20, 200, 660 V FS</p>	0.2U	2.0U	20.0U	200.0U	660.0U	
0.2U	2.0U	20.0U					
200.0U	660.0U						
<p>dC A DC Amperes</p>	<table border="1"> <tr> <td>2.0a</td> <td>20.0a</td> <td>200.0a</td> <td>5.0A</td> </tr> </table> <p>2, 20, 200 mA, 5 A FS</p>	2.0a	20.0a	200.0a	5.0A		
2.0a	20.0a	200.0a	5.0A				
<p>rAtio Strain Gauge</p>	<table border="1"> <tr> <td>0.2U</td> <td>2.0U</td> <td>20.0U</td> </tr> </table> <p>0.2, 2, 20 V FS</p>	0.2U	2.0U	20.0U			
0.2U	2.0U	20.0U					

TRUE RMS SIGNAL CONDITIONER

<p>AC U AC Volts</p>	<table border="1"> <tr> <td>0.2U</td> <td>2.0U</td> <td>20.0U</td> </tr> <tr> <td>200.0U</td> <td>660.0U</td> <td></td> </tr> </table> <p>0.2, 2, 20, 200, 660 V FS</p>	0.2U	2.0U	20.0U	200.0U	660.0U	
0.2U	2.0U	20.0U					
200.0U	660.0U						
<p>AC A AC Amperes</p>	<table border="1"> <tr> <td>2.0a</td> <td>20.0a</td> <td>200.0a</td> <td>5.0A</td> </tr> </table> <p>2, 20, 200 mA, 5 A FS</p>	2.0a	20.0a	200.0a	5.0A		
2.0a	20.0a	200.0a	5.0A				

MENU KEY 

DIGIT SELECT KEY 

VALUE SELECT KEY 

LOAD CELL SIGNAL CONDITIONER

<p>InPut Input signal type (continued)</p>	<p>Strn Load cells</p>	<p>20.0 50.0 100.0 250.0 500.0 20, 50, 100, 250, 500 mV FS</p>																				
	<p>dC u DC millivolts</p>	<p>20.0 50.0 100.0 250.0 500.0 20, 50, 100, 250, 500 mV FS</p>																				
<p>SEtuP Meter Setup</p>	<p>00000 Display selection</p>	<p>0 4 1/2 digits (0.1 Degree) 1 Remote display 2 4 1/2 digits [meter counts by 10] (.01 Degree) 3 3 1/2 digits (1 Degree)</p>																				
	<p>00000 Line frequency</p>	<p>0 60 Hz 1 50 Hz</p>																				
	<p>00000 Serial start & stop characters (Set through serial port).</p>	<p>0 Null start, <cr> stop 1 Special start and stop characters.</p>																				
	<p>00000 Method of scaling meter</p>	<p>0 Scale factor and offset 1 Coordinates of 2 points</p>																				
	<p>00000 Rear connector inputs A & B (negative true logic, 0V = true, +5V = false) (* A and B both low = function reset) A & B Logic levels for 6 & 7</p> <table border="1" data-bbox="643 1682 1052 1887"> <thead> <tr> <th>A</th> <th>B</th> <th>DP1</th> <th>DP2</th> </tr> </thead> <tbody> <tr> <td>1</td> <td>1</td> <td>XXXXX</td> <td>XXXX.X</td> </tr> <tr> <td>0</td> <td>1</td> <td>XXXX.X</td> <td>XXX.XX</td> </tr> <tr> <td>1</td> <td>0</td> <td>XXX.XX</td> <td>XX.XXX</td> </tr> <tr> <td>0</td> <td>0</td> <td>XX.XXX</td> <td>X.XXXX</td> </tr> </tbody> </table>	A	B	DP1	DP2	1	1	XXXXX	XXXX.X	0	1	XXXX.X	XXX.XX	1	0	XXX.XX	XX.XXX	0	0	XX.XXX	X.XXXX	<p>0 A: Reset B: Meter Hold 1 A: Function Reset B: Peak Display 2 * A: Meter Hold B: Peak Display 3 * A: Meter Hold B: Tare 4 * A: Peak Display B: Tare 5 A: Tare B: Reset 6 External Decimal Pts.1 7 External Decimal Pts.2</p>
A	B	DP1	DP2																			
1	1	XXXXX	XXXX.X																			
0	1	XXXX.X	XXX.XX																			
1	0	XXX.XX	XX.XXX																			
0	0	XX.XXX	X.XXXX																			

MENU KEY 

DIGIT SELECT KEY 

VALUE SELECT KEY 

ConFG Meter Configuration	00000 Operates as a rate of change meter Extended version only	0 Not rate of change 1 Rate x 0.1 2 Rate x 1 3 Rate x 10 4 Rate x 100 5 Rate x 1000 6 Rate x 10000
	00000 Selection of scaling by reading input signal or by Setup selection	0 Use setup scaling method 1 Scale by reading input
	00000 Selects between continuous (unlatched) data or single value (latched) of RS232 data when RTS is high or open	0 Unlatched 1 Latched
	00000 RS485 interface operates in the full duplex or half duplex mode	0 Full duplex mode 1 Half duplex mode
	00000 Scaling for nonlinear input Extended version only	0 Linear input 1 Custom curve
FiLtr Filtering	00000 Alarm filtering	0 Output is unfiltered 1 Output is filtered
	00000 Peak display filtering	0 Peak of unfiltered signal 1 Peak of filtered signal
	00000 Display filtering	0 Batch average, 16 rdgs 1 Display filtered signal

MENU KEY 

DIGIT SELECT KEY 

VALUE SELECT KEY 

<p>FiLtr Filtering (continued)</p>	<p>00000 Adaptive filter response</p> <p>00000 Input signal filtering</p>	<p>0 Low threshold level 1 High threshold level</p> <p>0 Autofilter 1 Batch avg, 16 rdgs. 2 Moving avg, .08 sec. 3 Moving avg, .15 sec. 4 Moving avg, .3 sec. 5 Moving avg, .6 sec. 6 Moving avg, 1.2 sec. 7 Moving avg, 2.4 sec. 8 Moving avg, 4.8 sec. 9 Moving avg, 9.6 sec. A Unfiltered</p>
<p>dEc.Pt Decimal point selection</p>	<p>d.ddd</p>	<p>d.ddd dd.ddd ddd.dd dddd.d dddd. .dddd</p>
<p>(Scale and Offset selected) SCALE Scale factor multiplier (not available for tC)</p>	<p>0.0000 0.0000 0.0000 0.0000 0.0000 0.0000</p>	<p>Select 0 through 9 for flashing digit and decimal point location when decimal point is flashing</p>
<p>OFFSt Offset or Zero Value</p>	<p>0.0000 0.0000 0.0000 0.0000 0.0000</p>	<p>Select 0 through 9 for flashing digit. Decimal point location is fixed by dEC.Pt selection</p>
<p>(coordinates of 2 pts method) Lo in Low signal input value (not available for tC & rtd)</p>	<p>0.0000 0.0000 0.0000 0.0000 0.0000</p>	<p>Select 0 through 9 for flashing digit. Decimal point location is fixed by input range chosen.</p>
<p>Lo rd Low Displayed Reading at Low Signal Input</p>	<p>0.0000 0.0000 0.0000 0.0000 0.0000</p>	<p>Select 0 through 9 for flashing digit. Decimal point location is fixed by dEC.Pt selection</p>
<p>Hi In High Signal Input Value</p>	<p>0.0000 0.0000 0.0000 0.0000 0.0000</p>	<p>Select 0 through 9 for flashing digit. Decimal point location determined by input range chosen.</p>

MENU KEY 

DIGIT SELECT KEY 

VALUE SELECT KEY 

<p>Hi rd High Displayed Reading at High Signal Input</p>	<p><u>0.0000</u> <u>0.0000</u> <u>0.0000</u> <u>0.0000</u> <u>0.0000</u></p>	<p>Select 0 through 9 for flashing digit. Decimal location is fixed by dEC.Pt selection.</p>
<p>rd0 In (custom curve only) Corrects for zero errors</p>	<p><u>04.000</u> Value set to actual voltage or current input at zero</p>	<p>Select 0 through 9 for flashing digit.</p>
<p>ALSEt Alarm Operation Setup (Only enabled if relay output is installed).</p>	<p><u>00000</u> Relay state when alarm is active</p>	<p>0 Relay 1 on, Relay 2 on 1 Relay 1 off, Relay 2 on 2 Relay 1 on, Relay 2 off 3 Relay 1 off, Relay 2 off</p>
	<p><u>00000</u> Alarm latching or nonlatching</p>	<p>0 Alarm 1 nonlatching, Alarm 2 nonlatching 1 Alarm 1 latching, Alarm 2 nonlatching 2 Alarm 1 nonlatching, Alarm 2 latching 3 Alarm 1 latching, Alarm 2 latching</p>
	<p><u>00000</u> Alarm status</p>	<p>0 AL1 active high, AL2 active high 1 AL1 active low, AL2 active high 2 AL1 disabled, AL2 active high 3 AL1 active high, AL2 active low 4 AL1 active low, AL2 active low 5 AL1 disabled, AL2 active low 6 AL1 active high, AL2 disabled 7 AL1 active low, AL2 disabled 8 AL1 disabled, AL2 disabled</p>

MENU KEY 

DIGIT SELECT KEY 

VALUE SELECT KEY 

<p>ALSEt (continued) Alarm Operation Setup</p>	<p>00000 Selection of Hysteresis mode or Band Deviation mode of alarms.</p>	<p>0 AL1 Band deviation AL2 Band deviation 1 AL1 Hysteresis AL2 Band deviation 2 AL1 Band deviation AL2 Hysteresis 3 AL1 Hysteresis AL2 Hysteresis 4 No deviation or hysteresis in menu</p>
	<p>00000 Number of readings in the alarm zone to cause an alarm</p>	<p>0 After 1 reading 1 After 2 readings 2 After 4 readings 3 After 8 readings 4 After 16 readings 5 After 32 readings 6 After 64 readings 7 After 128 readings</p>
<p>dEU1H Amount of deviation or hysteresis - Alarm 1 (Only enabled if relay output is installed).</p>	<p>00000 00000 00000 00000 00000 When the deviation value is >0, the alarms operate above and below setpoint by the value entered.</p>	<p>Select 0 through 9 for flashing digit.</p>
<p>dEU2b Amount of deviation or hysteresis - Alarm 2 (Only enabled if relay output is installed).</p>	<p>00000 00000 00000 00000 00000 When the deviation value is >0, the alarms operate above and below setpoint by the value entered.</p>	<p>Select 0 through 9 for flashing digit.</p>
<p>An Set Setup of analog output. (Only enabled if analog output board is installed).</p>	<p>00 Calibrated output is current or voltage.</p>	<p>0 Current output 1 Voltage output</p>
	<p>00 Analog output filtering</p>	<p>0 Analog output unfiltered 1 Analog output filtered</p>

MENU KEY 

DIGIT SELECT KEY 

VALUE SELECT KEY 

<p>(if analog output installed) An Lo Displayed value for 0 voltage or current output</p>	<p><u>0.0000</u> <u>0.0000</u> <u>0.0000</u> <u>0.0000</u> <u>0.0000</u></p>	<p>Select 0 through 9 for flashing digit. Decimal point location fixed by dEC.Pt selection.</p>																																
<p>An Hi Displayed value for 10 volts or 20 mA output</p>	<p><u>0.0000</u> <u>0.0000</u> <u>0.0000</u> <u>0.0000</u> <u>0.0000</u></p>	<p>Select 0 through 9 for flashing digit. Decimal fixed by DEC.Pt selection.</p>																																
<p>(if serial interface is installed) Ser_1 Serial interface setup <u>Fixed Parameters</u> No parity 8-bit word 1 stop bit</p>	<p><u>000</u> Output filtering</p>	<p><u>0</u> Send unfiltered signal <u>1</u> Send filtered signal</p>																																
	<p><u>000</u> Baud rate</p>	<p><u>0</u> 300 baud <u>1</u> 600 baud <u>2</u> 1200 baud <u>3</u> 2400 baud <u>4</u> 4800 baud <u>5</u> 9600 baud <u>6</u> 19200 baud</p>																																
	<p><u>000</u> Digital output rate (in seconds)</p>	<table border="0"> <tr> <td></td> <td><u>60 Hz</u></td> <td><u>50 Hz</u></td> </tr> <tr> <td><u>0</u></td> <td>Line frequency</td> <td></td> </tr> <tr> <td><u>1</u></td> <td>.28 sec</td> <td>.34 sec</td> </tr> <tr> <td><u>2</u></td> <td>.57 sec</td> <td>.68 sec</td> </tr> <tr> <td><u>3</u></td> <td>1.1 sec</td> <td>1.4 sec</td> </tr> <tr> <td><u>4</u></td> <td>2.3 sec</td> <td>2.7 sec</td> </tr> <tr> <td><u>5</u></td> <td>4.5 sec</td> <td>5.4 sec</td> </tr> <tr> <td><u>6</u></td> <td>9.1 sec</td> <td>10.9 sec</td> </tr> <tr> <td><u>7</u></td> <td>18.1 sec</td> <td>21.8 sec</td> </tr> <tr> <td><u>8</u></td> <td>36.3 sec</td> <td>43.5 sec</td> </tr> <tr> <td><u>9</u></td> <td>72.5 sec</td> <td>87 sec</td> </tr> </table>		<u>60 Hz</u>	<u>50 Hz</u>	<u>0</u>	Line frequency		<u>1</u>	.28 sec	.34 sec	<u>2</u>	.57 sec	.68 sec	<u>3</u>	1.1 sec	1.4 sec	<u>4</u>	2.3 sec	2.7 sec	<u>5</u>	4.5 sec	5.4 sec	<u>6</u>	9.1 sec	10.9 sec	<u>7</u>	18.1 sec	21.8 sec	<u>8</u>	36.3 sec	43.5 sec	<u>9</u>	72.5 sec
	<u>60 Hz</u>	<u>50 Hz</u>																																
<u>0</u>	Line frequency																																	
<u>1</u>	.28 sec	.34 sec																																
<u>2</u>	.57 sec	.68 sec																																
<u>3</u>	1.1 sec	1.4 sec																																
<u>4</u>	2.3 sec	2.7 sec																																
<u>5</u>	4.5 sec	5.4 sec																																
<u>6</u>	9.1 sec	10.9 sec																																
<u>7</u>	18.1 sec	21.8 sec																																
<u>8</u>	36.3 sec	43.5 sec																																
<u>9</u>	72.5 sec	87 sec																																
<p>Ser 2 Serial interface setup</p>	<p><u>0000</u> Line Feed</p>	<p><u>0</u> None after carriage rtn <u>1</u> LF after carriage return</p>																																
	<p><u>0000</u> Alarm data transmitted with meter readings</p>	<p><u>0</u> No alarm data <u>1</u> Alarm data with reading</p>																																
	<p><u>0000</u> Control of digital output</p>	<p><u>0</u> Continuous output <u>1</u> Output on RS-232 / RS-485 command only</p>																																

MENU KEY 

DIGIT SELECT KEY 

VALUE SELECT KEY 

<p>Ser 2 (continued) Serial interface setup</p>	<p>0000 Meter address for RS-232/RS-485 communication (digit display, address number of meter) Note: Addresses 1 through 15 are denoted by 1 through 9 and A through F. Addresses 16 through 31 use the same character followed by a decimal point.</p>	<table border="1"> <thead> <tr> <th>Meter#</th> <th>Display</th> </tr> </thead> <tbody> <tr><td>1</td><td>1</td></tr> <tr><td>2</td><td>2</td></tr> <tr><td>3</td><td>3</td></tr> <tr><td>4</td><td>4</td></tr> <tr><td>5</td><td>5</td></tr> <tr><td>6</td><td>6</td></tr> <tr><td>7</td><td>7</td></tr> <tr><td>8</td><td>8</td></tr> <tr><td>9</td><td>9</td></tr> <tr><td>10</td><td>a</td></tr> <tr><td>11</td><td>b</td></tr> <tr><td>12</td><td>C</td></tr> <tr><td>13</td><td>d</td></tr> <tr><td>14</td><td>E</td></tr> <tr><td>15</td><td>F</td></tr> <tr><td>16</td><td>0.</td></tr> <tr><td>17</td><td>1.</td></tr> <tr><td>18</td><td>2.</td></tr> <tr><td>19</td><td>3.</td></tr> <tr><td>20</td><td>4.</td></tr> <tr><td>21</td><td>5.</td></tr> <tr><td>22</td><td>6.</td></tr> <tr><td>23</td><td>7.</td></tr> <tr><td>24</td><td>8.</td></tr> <tr><td>25</td><td>9.</td></tr> <tr><td>26</td><td>A.</td></tr> <tr><td>27</td><td>b.</td></tr> <tr><td>28</td><td>C.</td></tr> <tr><td>29</td><td>d.</td></tr> <tr><td>30</td><td>E.</td></tr> <tr><td>31</td><td>F.</td></tr> </tbody> </table>	Meter#	Display	1	1	2	2	3	3	4	4	5	5	6	6	7	7	8	8	9	9	10	a	11	b	12	C	13	d	14	E	15	F	16	0.	17	1.	18	2.	19	3.	20	4.	21	5.	22	6.	23	7.	24	8.	25	9.	26	A.	27	b.	28	C.	29	d.	30	E.	31	F.
Meter#	Display																																																																	
1	1																																																																	
2	2																																																																	
3	3																																																																	
4	4																																																																	
5	5																																																																	
6	6																																																																	
7	7																																																																	
8	8																																																																	
9	9																																																																	
10	a																																																																	
11	b																																																																	
12	C																																																																	
13	d																																																																	
14	E																																																																	
15	F																																																																	
16	0.																																																																	
17	1.																																																																	
18	2.																																																																	
19	3.																																																																	
20	4.																																																																	
21	5.																																																																	
22	6.																																																																	
23	7.																																																																	
24	8.																																																																	
25	9.																																																																	
26	A.																																																																	
27	b.																																																																	
28	C.																																																																	
29	d.																																																																	
30	E.																																																																	
31	F.																																																																	
<p>Loc 1 Lockout of Menu Items (Lockout jumper must be removed to access Loc 1, 2, 3. See Figure 9.1)</p>	<p>00000 Input type selection</p>	<p>0 Enabled 1 Disabled</p>																																																																
	<p>00000 Meter setup, configuration and decimal point selection.</p>	<p>0 Enabled 1 Disabled</p>																																																																
	<p>00000 Filter</p>	<p>0 Enabled 1 Disabled</p>																																																																

MENU KEY 

DIGIT SELECT KEY 

VALUE SELECT KEY 

Loc 1 (continued) Lockout of Menu Items (Lockout jumper must be removed to access Loc 1, 2, 3. See Figure 9.1)	00000 Scale or Lo, Hi Input	0 Enabled 1 Disabled
	00000 Offset or Lo, Hi Reading	0 Enabled 1 Disabled
Loc 2 Lockout of Front Panel Keys (Lockout jumper must be removed to access Loc 1, 2, 3. See Figure 9.1)	0000 Alarm Setup	0 Enabled 1 Disabled
	0000 Alarm setpoint programming	0 Enabled 1 Disabled
	0000 Analog output scaling	0 Enabled 1 Disabled
	0000 Serial interface setup	0 Enabled 1 Disabled
Loc 3 Lockout of Front Panel Keys (Lockout jumper must be removed to access Loc 1, 2, 3. See Figure 9.1)	0000 View peak value pushbutton	0 Enabled 1 Disabled
	0000 View alarm setpoints pushbutton	0 Enabled 1 Disabled
	0000 Reset pushbutton (peak and latched alarms)	0 Enabled 1 Disabled
	0000 Reset pushbutton (meter reset)	0 Enabled 1 Disabled

10.

DC VOLTS & AMPS

This section is designed to provide basic meter setup instructions when a direct readout of voltage or current is required. When an external shunt is used to monitor current, the setup for process signals, section 11, should be used. Some menu items, such as leading zero blanking, display filtering, etc., are not discussed in this section and have been set to the most commonly used values. Should these items require change, refer to section 9 for selection information. For configuration of optional boards, see the appropriate section elsewhere in the manual.

10.1 RANGE JUMPER SELECTIONS

Voltage	
Input	Jumpers Required
200mV	E, b
2V	E, a
20V	F, g, b
200V	F, g, a
660V	F, h, a

Current	
Input	Jumpers Required
2mA	D, h, b
20mA	C, h, b
200mA	B, h, b
5A	A, h, b

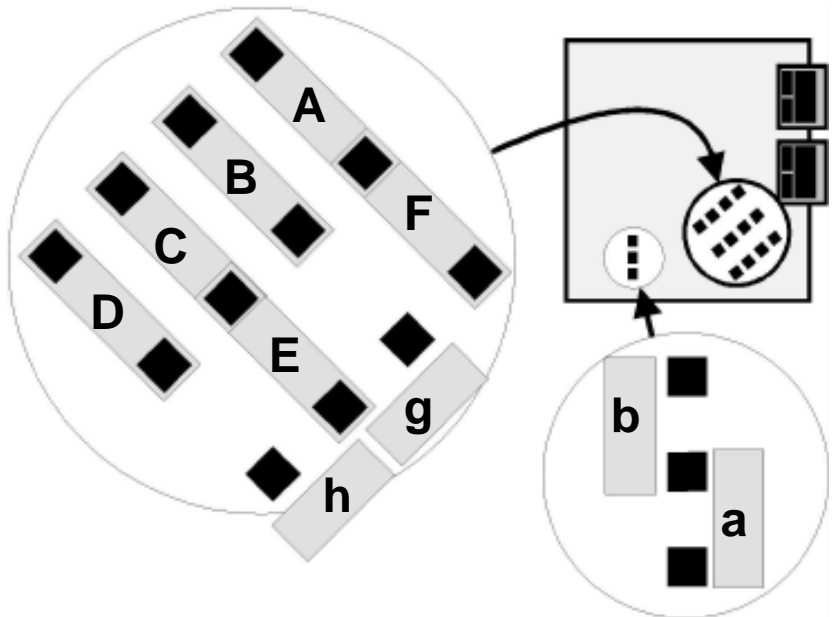

Figure 10.1 DC Signal Conditioner

- Notes**
1. See Section 21 to select 5,10 or 24Vdc excitation.
 2. Jumpers designated by capital letters require 5mm (0.2in) jumpers. Jumpers designated by lower case letters require 2.5mm (0.1 in) jumpers.
 3. Spare jumpers should be stored on single unused jumper posts not associated with capital letter designations

10.2 MENU SELECTION

Display of DC volts or amps is programmed by reading the input signal values (method 1), scale factor and offset (method 2) or coordinate of two points (method 3), see section 7 for a description of these scaling methods.























The following describes Method 2, Scale Factor and Offset.

Whenever the scale factor is 1.0 and offset is zero, the meter displays a direct readout of the signal input in (milli)volts or (milli)amperes. In the following example, the meter is configured for a full scale display of 0 to 20V or 0 to 20mA equals 20.000. Other ranges follow the same setup format. Note that the decimal point selection does not affect the displayed value. A full scale value of 20000 may be displayed as 20.000 milliamps or 20000 microamps. During setup, it may be necessary to enable some menu items that are locked out. See Section 8 for further information.

MENU KEY 

DIGIT SELECT KEY 

VALUE SELECT KEY 

<p>InPut</p> <p>Press the  key to display InPut (Input type selection). Note: Selection of input type & range must match jumper selection in Section 10.1</p>	<p>dC U</p> <p>Press  until dC U (dc Volts) is displayed</p> <p>dC A</p> <p>or dC A (DC Amps) is displayed.</p>	<p>20.0U</p> <p>Press  to select 0.2V, 2.0V, 20.0V, 200.0V, 660.0V</p> <p>20.0a</p> <p>or 2.0a, 20.0a, 200.0a (milliamps) or 5.0A (Amps)</p>
<p>SEtUP</p> <p>Press the  key to display SEtUP. (Basic setup) See Section 9, for detailed description of selections for digits 1 through 5.</p>	<p>30001</p> <p>1 2 3 4 5</p> <p>Press  to display status and select left digit. Press  again to select another digit. Selected digit will flash.</p>	<p>00000</p> <p>1 2 3 4 5</p> <p>Press  to select value for flashing digit.</p> <p>Digit 1: "0"= 20,000 cts. full scale "3"=2,000 cts. full scale Digit 4: "0" = scale and offset method</p>
<p>dEc.Pt</p> <p>Press the  key to display dEcPt (Decimal point).</p>	<p>d.ddddd</p> <p>Press  to display location of decimal point.</p>	<p>dd.dddd</p> <p>Press  to change decimal point location.</p>
<p>SCALE</p> <p>Press the  key to display SCALE (Scale factor).</p>	<p>005.00</p> <p>Press  to display value and select left digit. Press  again to select another digit.</p>	<p>1.0000</p> <p>Press  to set digit values. Set value and decimal to 1.0 (1.0000, 01.000, etc)</p>
<p>OFFSt</p> <p>Press the  key to display OFFSt (Zero offset).</p>	<p>0.1250</p> <p>Press  to display value and select left digit. Press  again to select another digit.</p>	<p>00.0000</p> <p>Press  to set digit values. Set value to 00.000. Decimal point is fixed by decimal point</p>
<p>rESEt</p> <p>20.0000</p> <p>Press the  key. Continue to press  (or  and  simultaneously) until rESEt is displayed. The meter will now go to the operating mode and display the value of the input signal.</p>		

11.

PROCESS SIGNAL INPUTS

This section provides basic meter setup instructions for a direct readout in engineering units such as psi, rpm, etc. The signal input may come from a transducer or other voltage or current source. Some menu items, such as leading zero blanking, display filtering, etc., are not discussed in this section and have been set to the most commonly used values. Should these items require change, refer to section 9 for selection information. For configuration of optional boards, see the appropriate section elsewhere in the manual.

11.1 RANGE JUMPER SELECTIONS

Voltage	
Input	Jumpers Required
200mV	E, b
2V	E, a
20V	F, g, b
200V	F, g, a
660V	F, h, a

Current	
Input	Jumpers Required
2mA	D, h, b
20mA	C, h, b
200mA	B, h, b
5A	A, h, b

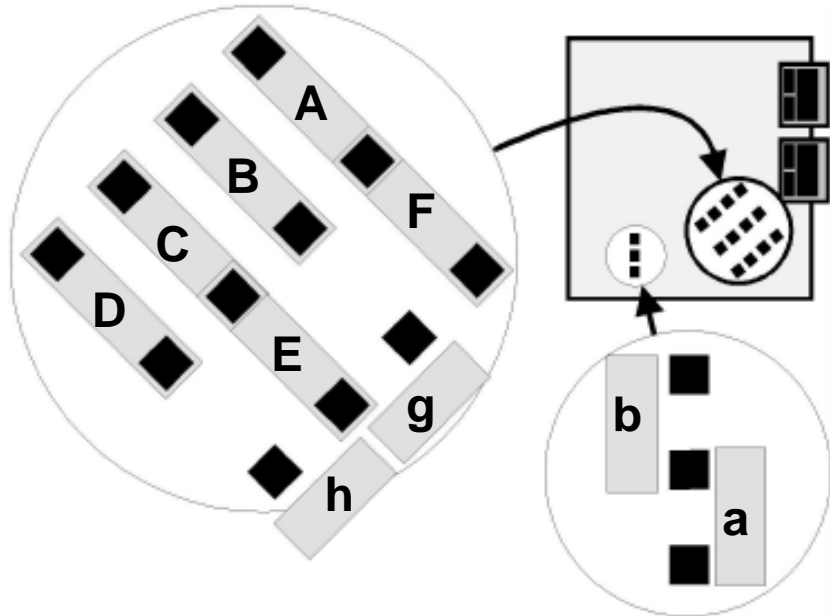

Figure 11.1 DC Signal Conditioner

- Notes**
1. See Section 21 to select 5, 10 or 24Vdc excitation.
 2. Jumpers designated by capital letters require 5mm (0.2in) jumpers. Jumpers designated by lower case letters require 2.5mm (0.1 in) jumpers.
 3. Spare jumpers should be stored on single unused jumper posts not associated with capital letter designations

11.2 MENU SELECTION

There are three methods of scaling the meters: by reading the signal values (method 1), scale factor and offset (method 2) or coordinates of 2 points (method 3), see section 7. Display in engineering units is most easily programmed using methods 1 or 3. An example of programming method 1 is shown for the "load cells and microvolt inputs", section 16. The following example is for Method 3 where you must enter the four values (low signal input, desired reading at the low signal input, high signal input and desired reading at the high signal input) directly via the front panel pushbuttons or the RS232 interface. To use Method 3, you must select ConFG digit 2, "0" i.e. 00000 .

Method 3: Coordinates of 2 points (example 4 to 20mA = 0 to 100.00)
 Enter the values for low signal input (04.000), low display (000.00), high signal input (20.000) and high display (100.00) are entered. The following example uses this scaling method.

Signal input is 4 to 20mA and displayed value is 000.00 (at 4mA) to 100.00 (at 20mA). When setting up the meter, it may be necessary to enable some menu items. See Section 8 for further information.

<div style="border: 1px solid black; padding: 2px; display: inline-block;"> MENU KEY ^{MENU}> </div>	<div style="border: 1px solid black; padding: 2px; display: inline-block;"> DIGIT SELECT KEY ^{PEAK}> </div>	<div style="border: 1px solid black; padding: 2px; display: inline-block;"> VALUE SELECT KEY ^{RESET}^ </div>
<div style="border: 1px solid black; padding: 5px; text-align: center; font-family: monospace; font-size: 1.2em;">InPut</div> <p>Press the ^{MENU}> key to display InPut (Input type selection). Note: Selection of input type & range must match jumper selection in Section 11.1.</p>	<div style="border: 1px solid black; padding: 5px; text-align: center; font-family: monospace; font-size: 1.2em;">dC A</div> <p>Press ^{PEAK}> until dC A (DC Amperes) is displayed. (dC U if voltage input).</p>	<div style="border: 1px solid black; padding: 5px; text-align: center; font-family: monospace; font-size: 1.2em;">20.0a</div> <p>Press ^{RESET}^ to select 2.0a, 20.0a, 200.0a (milliamps) or 5.0A (Amps). (.20U, 2.0U, 20.0U, 200.0U or 660.0U if voltage input)</p>
<div style="border: 1px solid black; padding: 5px; text-align: center; font-family: monospace; font-size: 1.2em;">SEtUP</div> <p>Press the ^{MENU}> key to display SEtUP. (Basic setup) See Section 9, for detailed description of selections for digits 1 through 5.</p>	<div style="border: 1px solid black; padding: 5px; text-align: center; font-family: monospace; font-size: 1.2em;">30000</div> <p style="text-align: center; font-size: 0.8em;">1 2 3 4 5</p> <p>Press ^{PEAK}> to display status and select left digit. Press ^{PEAK}> again to select another digit. Selected digit will flash.</p>	<div style="border: 1px solid black; padding: 5px; text-align: center; font-family: monospace; font-size: 1.2em;">00010</div> <p style="text-align: center; font-size: 0.8em;">1 2 3 4 5</p> <p>Press ^{RESET}^ to select value for flashing digit. Digit 1: "0"= 20,000 cts FS "3"=2,000 cts FS Digit 4: "0"=scale & offset "1"=2- coordinate</p>
<div style="border: 1px solid black; padding: 5px; text-align: center; font-family: monospace; font-size: 1.2em;">dEc.Pt</div> <p>Press the ^{MENU}> key to display dEcPt (Decimal point).</p>	<div style="border: 1px solid black; padding: 5px; text-align: center; font-family: monospace; font-size: 1.2em;">d.dddd</div> <p>Press ^{PEAK}> to display decimal point location.</p>	<div style="border: 1px solid black; padding: 5px; text-align: center; font-family: monospace; font-size: 1.2em;">d.d.d.d</div> <p>Press ^{RESET}^ to change decimal point location.</p>
<div style="border: 1px solid black; padding: 5px; text-align: center; font-family: monospace; font-size: 1.2em;">Lo in</div> <p>Press the ^{MENU}> key to display Lo in (Low signal input value).</p>	<div style="border: 1px solid black; padding: 5px; text-align: center; font-family: monospace; font-size: 1.2em;">00.000</div> <p>Press ^{PEAK}> to display value and select left digit. Press again to select another digit. Dec pt. fixed by input range.</p>	<div style="border: 1px solid black; padding: 5px; text-align: center; font-family: monospace; font-size: 1.2em;">04.000</div> <p>Press ^{RESET}^ to set digit values and set to 04.000 (4 mA). Most significant digit may be set to 0 thru 9 and -0 thru -9.</p>
<div style="border: 1px solid black; padding: 5px; text-align: center; font-family: monospace; font-size: 1.2em;">Lo rd</div> <p>Press the ^{MENU}> key to display Lo rd (Desired meter reading at low signal input).</p>	<div style="border: 1px solid black; padding: 5px; text-align: center; font-family: monospace; font-size: 1.2em;">000.000</div> <p>Press ^{PEAK}> to display value and select left digit. Press ^{PEAK}> again to select another digit. Decimal point set by Dec.Pt.</p>	<div style="border: 1px solid black; padding: 5px; text-align: center; font-family: monospace; font-size: 1.2em;">000.00</div> <p>Press ^{RESET}^ to set digit values and set to 000.00 .</p>
<div style="border: 1px solid black; padding: 5px; text-align: center; font-family: monospace; font-size: 1.2em;">Hi In</div> <p>Press the ^{MENU}> key to display Hi in (High signal input value).</p>	<div style="border: 1px solid black; padding: 5px; text-align: center; font-family: monospace; font-size: 1.2em;">00.000</div> <p>Press ^{PEAK}> to display value and select left digit. Press ^{PEAK}> again to select another digit. Dec pt. fixed by input range.</p>	<div style="border: 1px solid black; padding: 5px; text-align: center; font-family: monospace; font-size: 1.2em;">20.000</div> <p>Press ^{RESET}^ to set digit values and set to 20.000 (20 mA).</p>

MENU KEY 



DIGIT SELECT KEY 

VALUE SELECT KEY 





Press the  key to display Hi rd (Desired meter reading at high signal input).







Press  to display value and select left digit. Press  to select another digit. Decimal point set by Dec.Pt.



Use  to set digit values and set to 100.00 .



Press the  key. Continue to press  (or  and  simultaneously) until rESET is displayed. The meter will now go to the operating mode and display the value of the input signal.



12.

THERMOCOUPLES

12.1 RANGE JUMPER SELECTIONS

Thermocouple Type

Type	Jumpers Required
J, K, E, N	e
T, R, S	f

Open Thermocouple

Open TC Indication	Jumpers Required
Upscale	c
Downscale	d

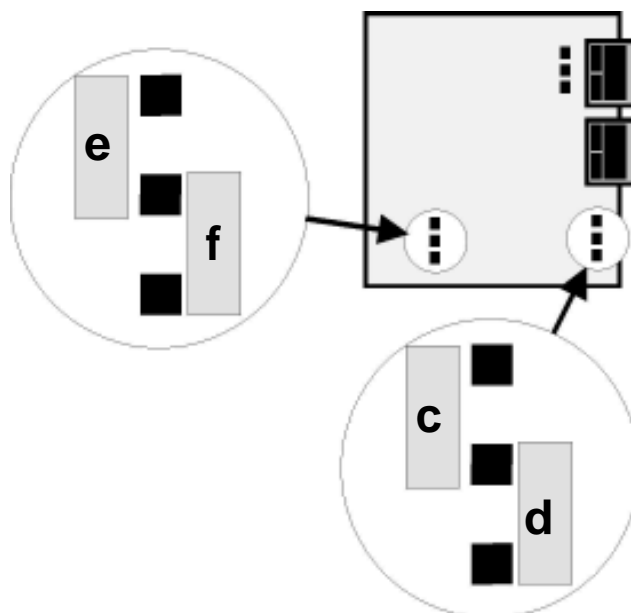

Figure 12.1 Temperature Signal Conditioner

12.2 MENU SELECTION

Thermocouple type and Celsius or Fahrenheit scale are selected by input type. However, Kelvin or Rankine may be displayed by entering the appropriate offset to the selected scale. Although 0.01 degree resolution may be selected, it is not recommended for use with thermocouples. When setting up the meter, it may be necessary to enable some of the menu items. See Section 8 for further information.

MENU KEY 



DIGIT SELECT KEY 

VALUE SELECT KEY 

INPut

Press the  key to display InPut (Input type selection).
Note: Selection of input type & range must match jumper selection in Section 12.1.

tC

Press  to display input selected. Press  again until tC (thermocouple) is displayed.



J °C

Press  to select thermocouple type J, K, N, T, E, S, R and °C or °F scale (J°F, J°C, K°F, K°C, N°F, N°C, t°F, t°C, E°F, E°C, S°F, S°C, r°F, r°C)

SEtUP

Press the  key to display SEtUP. (Basic setup)
See Section 9, for detailed description of selections for digits 1 through 5.

30000

Press  to display status and select left digit. Press  again to select another digit. Selected digit will flash.



00000

Press  to select value for flashing digit.
Digit 1:
"0" = 0.1 degree resolution
"3" = 1 degree resolution

OFFSt

Press the  key to display OFFSt (Zero offset).

0000.0

Press  to display value and select left digit. Press  again to select another digit.





0000.0

Press  to set digit values and set to 000.00 for °F and °C or

0273.2

set value to 273.2 if °C is selected to display in °Kelvin and 459.7 if °F is selected to display in ° Rankine.

rESEt

Press the  key. Continue to press  (or  and  simultaneously) until rESEt is displayed. The meter will now go to the operating mode and display the value of the input signal.

45.19

13.

Pt100 RTD'S

13.1 RANGE JUMPER SELECTION

All RTD Types

Jumpers Required 2-,4-wire
b, f
Jumpers Required 3--wire
a, f

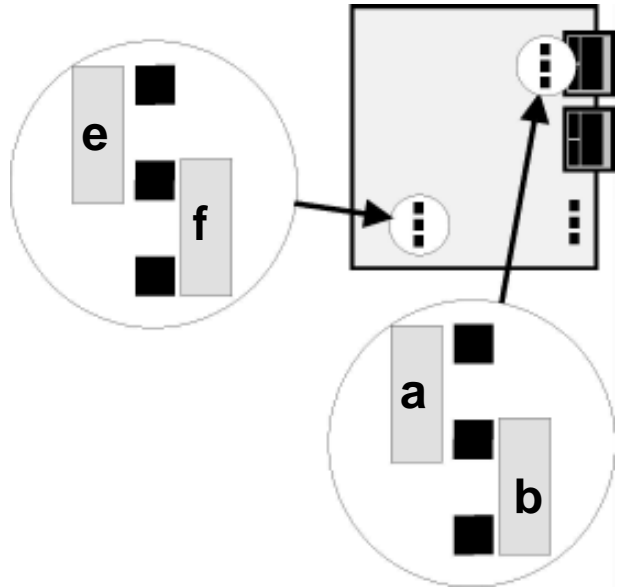

Figure 13.1 Temperature Signal Conditioner

Notes:

- 1) See Section 21 to select 10 Vdc excitation.
- 2) Jumper **e** only used with Thermocouple input applications (see Section 12).





































13.2 2-WIRE RTD LEAD COMPENSATION

This section describes how to remove the error caused by lead resistance in a 2-wire RTD. Ambient temperature changes will cause some error in the readings; the higher the lead resistance, the greater the error. When performing this procedure, the leads should be shorted together as close as possible to the RTD. This step is not necessary when using 3- or 4-wire RTD's since lead resistance compensation is automatic in the meter. When setting up the meter, it may be necessary to enable some of the menu items. See Section 8 for further information.

<p>MENU KEY MENU ➤</p>	<p>DIGIT SELECT KEY PEAK ➤</p>	<p>VALUE SELECT KEY RESET ⤴</p>
<p>INPut</p> <p>Press the MENU key to display InPut (Input type selection).</p>	<p>rtd</p> <p>Press PEAK to display input selected. Press PEAK again until rtd is displayed.</p>	<p>Short</p> <p>Press RESET to select short.</p>
<p>rESEt 1.4</p> <p>Press the MENU key until rESEt is displayed. Short the input leads at the RTD sensor. Press the PEAK key to store value. Set up for RTD per section 13.3</p>		

13.3 MENU SELECTIONS

The following example is setup for a 4-wire DIN RTD. When setting up the meter, it may be necessary to enable some of the menu items. See Section 8 for further information.

MENU KEY 	DIGIT SELECT KEY 	VALUE SELECT KEY 
<p></p> <p>Press the  key to display InPut (Input type selection). Note: Selection of input type & range must match jumper selection in Section 13.1.</p>	<p></p> <p>Press  until rtd (resistance temperature detector) is displayed</p>	<p></p> <p>Press  to select rtd type (4d°F, 4d°C, 4A°F, 4A°C, 3d°F, 3d°C, 3A°F, 3A°C, 2d°F, 2d°C, 2A°F, 2A°C) Number = # of leads Letter = Din or ANSI RTD</p>
<p></p> <p>Press the  key to display SEtUP. (Basic setup) See Section 9, for detailed description of selections for digits 1 through 5.</p>	<p></p> <p>Press  to display status and select left digit. Press  again to select another digit. Selected digit will flash.</p>	<p></p> <p>Press  to select value for flashing digit. Digit 1: "0" = 0.1 degree resolution "2" = 0.01 degree resolution "3" = 1 degree resolution</p>
<p></p> <p>Press the  key to display SCALE. Divide 100 by resistance of RTD at 0° C to calculate scale factor.</p>	<p></p> <p>Press  to display value and select left digit. Press again to select another digit.</p>	<p></p> <p>Use  to set digit values. Set value and decimal to calculated scale factor.</p>
<p></p> <p>Press the  key to display OFFSt (Zero offset).</p>	<p></p> <p>Press  to display value and select left digit. Press  again to select another digit.</p>	<p></p> <p>Use  to set digit values and set to 000.00 for °F and °C or</p> <p></p> <p>set value to 273.2 if °C is selected to display in °Kelvin and 459.7 if °F is selected to display in ° Rankine.</p>
<p> </p> <p>Press the  key. Continue to press  (or  and  simultaneously) until rESEt is displayed. The meter will go to the operating mode and display the value of the input signal.</p>		

14.

STRAIN GAUGES AND POTENTIOMETERS

14.1 RANGE JUMPER SELECTIONS

Voltage	
Input	Jumpers Required
200mV	E, b
2V	E, a
20V	F, g, b

Notes

1. See Section 21 to select 10Vdc or to remove jumpers for external excitation.
2. Jumpers designated by lower case letters require 2.5mm (0.1 in) jumpers.
3. Spare jumpers should be stored on single unused jumper posts.

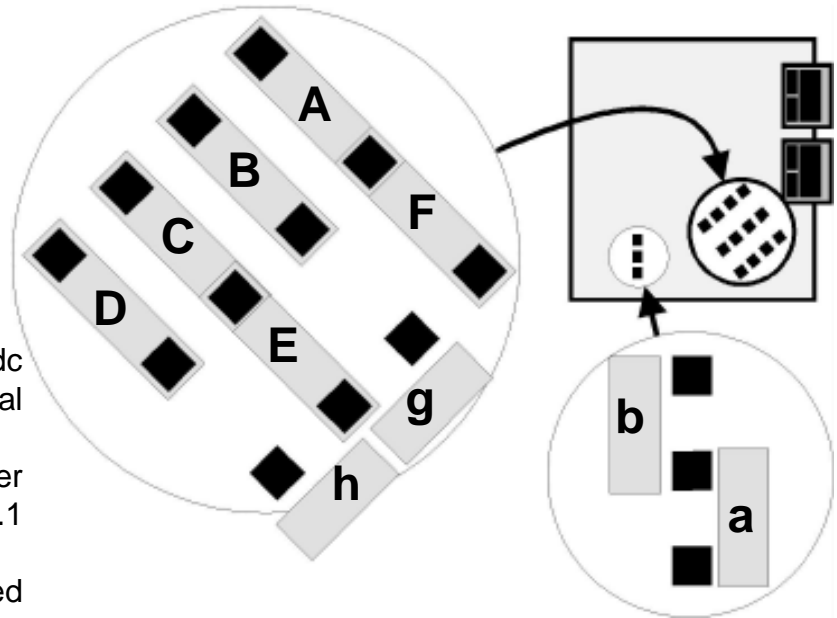

Figure 14. 1 DC Signal Conditioner

14.2 MENU SELECTION

There are three methods of scaling the meters: by reading the signal values (method 1), scale factor and offset (method 2) or coordinates of 2 points (method 3), see section 7. Display in engineering units is most easily programmed using methods 1 or 3. An example of programming method 1 is shown for the "load cells and microvolt inputs", section 16. The following example is for Method 3 where you must enter the four values (low signal input, desired reading at the low signal input, high signal input and desired reading at the high signal input) directly via the front panel pushbuttons or the RS232 interface. To use Method 3, you must select ConFG digit 2, "0" i.e.

Method 3: Coordinates of 2 points (example 4 to 20mA = 0 to 100.00)

Enter the values for low signal input (04.000), low display (000.00), high signal input (20.000) and high display (100.00) are entered. The following example uses this scaling method. Signal input is 4 to 20mA and displayed value is 000.00 (at 4mA) to 100.00 (at 20mA). When setting up the meter, it may be necessary to enable some menu items. See Section 8 for further information.



<p>Press the ^{MENU} > key to display InPut. Note: Range selection must match jumper selection in Section 14.1 .</p>	<p>Press ^{PEAK} > until rAtio (Ratio-metric operation) is displayed.</p>	<p>Press ^{RESET} ^ to select 0.2U, 2.0U or 20.0U (200mV, 2V or 20Vdc).</p>

MENU KEY 



DIGIT SELECT KEY 

VALUE SELECT KEY 

SEtUP

Press the  key to display SEtUP. (Basic setup). See Section 9, for detailed description of selections for digits 1 through 5.

30000

Press  to display status. Press  again to select another digit. Selected digit will flash.

00010

Press  to select value. Digit 1: "0"= 20,000 cts. FS
"2"=LSD fixed zero
"3"=2,000 cts. FS
Digit 4: "1" for 2 point scaling

dEcPt

Press the  key to display dEcPt (Decimal point).

d.dddd

Press  to display decimal point location.



ddd.dd

Press  to select decimal point location.

Lo in

Press the  key to display Lo in (Low signal input value).

.00000

Press  to display value. Press  again to select another digit. **Note:** Decimal point is fixed by input range selection.

.00000

Press  to set digit values and set to .00000 (0mV). **Note:** Most significant digit may be set to 0 thru 9 and -0 thru -9.

Lo rd

Press the  key to display Lo rd (Desired meter reading at low signal input).

000.00

Press  to display value. **Note:** Decimal point is fixed by dEcPt selection.

000.00

Press  to set digit values and set to 000.00

Hi in

Press the  key to display Hi in (High signal input value).

.00000

Press  to display value. **Note:** Decimal point is fixed by input range selection.

.02000

Press  to set digit values and set to .02000 (20mV)

Hi rd

Press the  key to display Hi rd (Desired meter reading at high signal input).





000.00

Press  to display value. **Note:** Decimal point is fixed by dEcPt selection.

100.00

Press  to set digit values and set to 100.00

rESEt

Press the  key. Continue to press  (or  and  simultaneously) until rESEt is displayed. The meter will now go to the operating mode and display the value of the input signal.

100.00

15.

AC (RMS) VOLTS & AMPS

This section provides basic setup instructions for true RMS voltage or current monitoring. An RMS signal conditioner is required. Some menu items, such as leading zero blanking, display filtering, etc., are not discussed in this section and have been set to the most commonly used values. Should these items require change, refer to section 9 for selection information. For configuration of optional boards, see the appropriate section elsewhere in the manual.

15.1 RANGE JUMPER SELECTIONS

Voltage	
Input	Jumpers Required
	AC Coupled
200mV	g, k
2V	g, j
20V	h, k
200V	h, j
660V	f, j

Current	
Input	Jumpers Required
	AC Coupled
2mA	e, f, k
20mA	d, f, k
200mA	c, f, k
5A	a, b, f, m

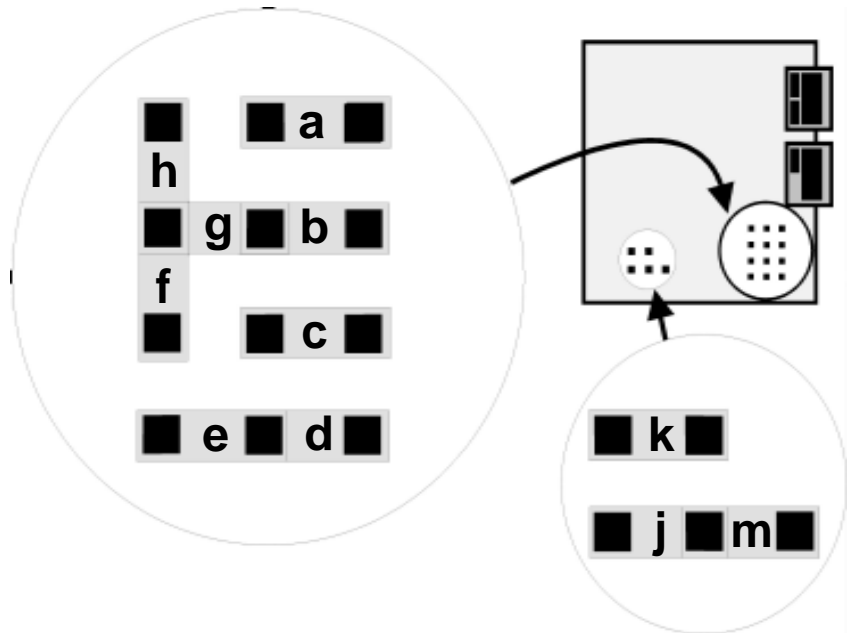

Figure 15. 1 RMS Signal Conditioner

- Notes**
- Jumpers designated by capital letters require 5mm (0.2in) jumpers. Jumpers designated by lower case letters require 2.5mm (0.1 in) jumpers.
 - Spare jumpers should be stored on single unused jumper posts not associated with capital letter designations

15.2 MENU SELECTION

Display in engineering units is programmed by reading the input signal values (method 1), scale factor and offset (method 2) or coordinate of two points (method 3), see section 7. When Scale Factor and Offset is selected (this is the factory default), and the scale factor is 1.0 and offset is zero, the meter displays a direct readout of the signal input in (milli)volts or (milli) amperes.







































Method 2, Scale Factor and Offset:

In the following example, the meter is configured for a full scale display of 0 to 20V or 0 to 20mA equals 20.000. Other ranges follow the same setup format. Note that the decimal point selection does not affect the displayed value. A full scale value of 20000 may be displayed as 20.000 Volts or 20000 millivolts. When an external shunt or current transformer is used to monitor current, the appropriate scale factor must be entered. A 5A CT input to the meter displays 20000 (2000 when 3 1/2 digit is selected). For an 800 Amp CT, divide 8000 (desired full scale display with .1 Amp resolution) by 20000 (full scale when the scale factor is 1.0) for the correct scale factor. Enter .4 as a scale factor. During setup, it may be necessary to enable some menu items that are locked out. See Section 8 for further information.

MENU KEY 

PEAK SELECT KEY 

VALUE SELECT KEY 

<p></p> <p>Press the  key to display InPut (Input type selection).</p> <p>Note: Selection of input type & range must match jumper selection in Section 15.1.</p>	<p></p> <p>Press  until AC U (ac Volts) is displayed or</p> <p></p> <p>AC A (ac Amperes) is displayed.</p>	<p></p> <p>Press  to select 0.2V, 2.0V, 20.0V, 200.0V or 660.0V or</p> <p></p> <p>2.0a, 20.0a, 200.0a (milliamps) or 5.0A (Amps)</p>
<p></p> <p>Press the  key to display SEtUP. (Basic setup). See Section 9, for detailed description of selections for digits 1 through 5.</p>	<p></p> <p>Press  to display status and select left digit. Press  again to select another digit. Selected digit will flash.</p>	<p></p> <p>Press  to select value for flashing digit.</p> <p>Digit 1: "0"= 20,000 cts. full scale "2"=Same as "0" but LSD is fixed zero. "3"=2,000 cts. full scale</p> <p>Digit 4: Set to "0" for scale and offset</p>
<p></p> <p>Press the  key to display dEcPt (Decimal point).</p>	<p></p> <p>Press  to display decimal point location.</p>	<p></p> <p>Press  to select decimal point location.</p>
<p></p> <p>Press the  key to display SCALE (Scale factor).</p>	<p></p> <p>Press  to display value and select left digit. Press again to select another digit.</p>	<p></p> <p>Press  to set digit values. Set value and decimal to 1.0 or appropriate multiplier for external shunts or CT's.</p>
<p></p> <p>Press the  key to display OFFSt (Zero offset).</p>	<p></p> <p>Press  to display value and select left digit. Press again to select another digit.</p>	<p></p> <p>Press  to set digit values. Set value to 00.000. Decimal point is fixed by Dec.Pt.</p>
<p></p> <p></p> <p>Press the  key. Continue to press  (or  and  simultaneously) until rESEt is displayed. The meter will now go to the operating mode and display the value of the input signal.</p>		

16.

LOAD CELLS AND MICROVOLT INPUTS

This section provides setup instructions for use as a microvoltmeter or with load cells and strain gauges. 10 Volt excitation will power up to four 350 Ohm load cells. Sense leads may be used to compensate for lead resistance of the excitation supply. For configuration of optional boards, see the appropriate section elsewhere in the manual.

16.1 RANGE JUMPER LOCATIONS

Input	Jumper Locations	Full Scale Display Scale factor = 1
20mV	e	20000
50mV	a	50000
100mV	b	10000
250mV	c	25000
500mV	d	50000

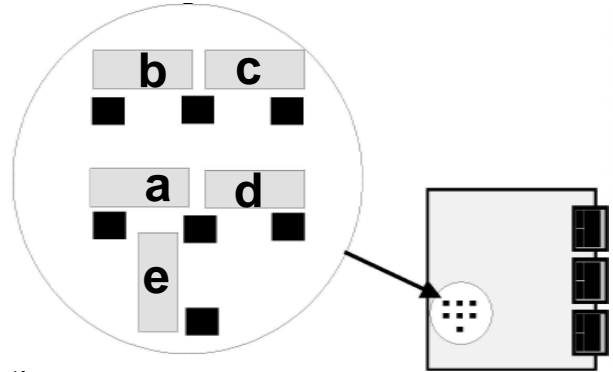

- Notes 1. See Section 21 to select 10V excitation.
 2. Jumpers are 2.5mm (0.1 in).

Figure 16.1 Load Cell Signal Conditioner

16.2 MENU SELECTION













































There are three methods of scaling the meters: by reading the signal values (method 1), scale factor and offset (method 2) or coordinates of 2 points (method 3), see section 7. Display in engineering units is most easily programmed using methods 1 or 3. An example of programming method 2 is shown for the "dc volts and amps", section 10. The following example is for Method 1 where the low signal input and high signal input values are read directly by the meter and are then stored as Lo in and Hi in. For example, the full scale range of a load cell is 500 pounds and has an output of 2mV/V (2 millivolts per volt of excitation). With 10V excitation, the full scale range of 20mV is selected by jumper (see the above chart) which will display a resolution of 0.01 pounds. With no weight on the scale (load cell) the meter should read 0.00 and with a 500 pound weight on the scale (load cell), the meter should display 500.00 pounds. With no weight on the load cell, press the **Menu Key** to select **Lo in** (low input) and then press the **Digit Select (Peak) Key**. The meter will take readings and display the millivolt value of the input signal. Pressing the **Value Select (Reset) Key** will store this reading as the **Lo in**. Press the **Menu Key** to select **Hi in** (high input), place the 500 pound weight on the scale (load cell) and repeat the procedure the same as for **Lo in**. Press the **Menu Key** to select **Lo rd** (Low Reading) and enter 000.00, then press the **Menu Key** to select **Hi rd** (high reading) and enter 500.00. Advantages of this method are accuracy, since reading the value corrects for any error in the transducer, and ease of re-calibration. To re-calibrate the meter, take readings at 0 and 500 pounds, Lo rd and Hi rd do not need to be reentered. If a 500 pound weight was not available, the same result can be achieved by using any known weight. During Setup, it may be necessary to enable some menu items. See Section 8 for further information. See Section 11 for an example of scaling using the coordinate of two points (direct data entry) method of scaling in engineering units.

MENU KEY MENU 	DIGIT SELECT KEY PEAK 	VALUE SELECT KEY RESET
<p>Press the MENU key to display InPut (Input type selection).</p>	<p>Press PEAK until Strn (ratiometric) is displayed.</p>	<p>Press RESET to select 20.0, 50.0, 100.0, 250.0 or 500.0mV</p>

MENU KEY 

DIGIT SELECT KEY 

VALUE SELECT KEY 

























 <p>Press the  key to display ConFG (configuration menu). See Section 9 for detailed description of digits 1 thru 5.</p>	 <p>Press  to display status. Press  again to select digit. Selected digit will flash.</p>	 <p>Press  to select value. Selection of "1" for digit 2 selects scaling Method 1.</p>
 <p>Press the  key to display dEcPt (Decimal point).</p>	 <p>Press  to display decimal point location.</p>	 <p>Press  to change decimal point location.</p>
 <p>Press the  key to display Lo in (Low signal input value). Apply an input for a known low value.</p>	 <p>Press  to display the input signal. The meter will momentarily blank and then display the low input.</p>	 <p>Press  to store the reading as the low input.</p>
 <p>Press the  key to display Hi in (high signal input value). Apply an input for a known high value.</p>	 <p>Press  to display the input signal. The meter will momentarily blank and then display the high input.</p>	 <p>Press  to store the reading as the high input.</p>
 <p>Press the  key to display Lo rd (desired meter reading at low signal input).</p>	 <p>Press  to display the value and select a digit. Press  again to select another digit. Dec. pt. fixed by input range.</p>	 <p>Press  to set digit value. Select 0 thru 9 for the flashing digit i.e. 000.00.</p>
 <p>Press the  key to display Hi rd (desired meter reading at high signal input).</p>	 <p>Press  to display the value and select a digit. Press  again to select another digit. Decimal point set by dEc.Pt .</p>	 <p>Press  to set digit value. Select 0 thru 9 for the flashing digit i.e. 500.00.</p>
 <p>Press the  key. Continue to press  (or  and  simultaneously) until rESET is displayed. The meter will go to the operating mode and display the value of the input signal.</p>		

17.

DUAL SETPOINT CONTROLLER

17.1 OPERATING MODE MENU SELECTION

When setting up the meter, it may be necessary to enable some of the menu items. See Section 8 for further information.

MENU KEY 	DIGIT SELECT KEY 	VALUE SELECT KEY 
<p style="text-align: center;"></p> <p>Press the  key until ALSEt (Alarm setup) is displayed. See Section 9, ALSEt for detailed selection information for Digits 1 through 5.</p>	<p style="text-align: center;"> 1 2 3 4 5</p> <p>Press  to display status. Press  again to select digit. Selected digit will flash.</p>	<p style="text-align: center;"> 1 2 3 4 5</p> <p>Press  to select value for flashing digit Digit 1: Relay state in alarm Digit 2: Latching or non-latching output Digit 3: Alarm high, low or disabled Digit 4: Hysteresis or deviation Digit 5: Time delay</p>
<p style="text-align: center;"></p> <p>Press the  key and dEU1b (Alarm 1 band deviation) or dEU1H (Alarm 1 hysteresis) is displayed if ALSEt digit 4 is not set to 4.</p>	<p style="text-align: center;"></p> <p>Press  to display value. Press  again to select digit. Selected digit will flash.</p>	<p style="text-align: center;"></p> <p>Using  to set digit value 0 to 9, enter deviation value for setpoint1. Relays turn on and off at setpoint if value is zero.</p>
<p style="text-align: center;"></p> <p>Press the  key and dEU2b (Alarm 2 band deviation) or dEU2H (Alarm 2 hysteresis) is displayed if ALSEt digit 4 is not set to 4.</p>	<p style="text-align: center;"></p> <p>Press  to display value. Press  again to select digit. Selected digit will flash.</p>	<p style="text-align: center;"></p> <p>Using  to set digit value 0 to 9, enter deviation value for setpoint2. Relays turn on and off at setpoint if value is zero.</p>

17.2 NORMAL OPERATION

When deviation and hysteresis are not enabled or deviation is set to zero, the alarm energizes at and above the setpoint and deenergizes below the setpoint if high alarm is selected. The alarm energizes at and below the setpoint and deenergizes above the the setpoint if low alarm is selected. The setpoint value is not displayed if the alarm is disabled.

17.3 BAND DEVIATION



















When deviation is selected from the setup menu, a value is entered for the amount of deviation required. This value represents the number of counts at which the relay will be energized above and below the setpoint. For example, if the setpoint is set to 10,000 and a deviation value of 200 was entered, the relay will activate below 9800 and above 10,200.

17.4 HYSTERESIS

When hysteresis is selected from the setup menu, a value is entered for the amount of hysteresis required. This value represents the number of counts at which the relay will be energized above and deenergized below the setpoint. For example, if the setpoint is set to 10,000 and a hysteresis value of 200 was entered, the relay will activate at 10200 and deactivate at 9800.

17.5 VIEWING AND CHANGING SETPOINTS

When viewing or changing the setpoint values, it is not necessary to enter the setup menu. This allows the meter to continue to make conversions and provide outputs when the setpoint values are displayed.

MENU KEY 	DIGIT SELECT KEY 	VALUE SELECT KEY 
		
Press the  key to display Alarm 1 value.	Alarm value blinks and Alarm 1 LED indicator lights. Press  to select digit.	Use  to select digit and  to change the digit value, enter setpoint 1 value.
Press  key again to store Alarm 1 value and display Alarm 2 value.		
	Alarm value blinks and Alarm 2 LED indicator lights. Press  to select digit.	Use  to select digit and  to change the digit value, enter setpoint 2 value.
		
Press  key again to store alarm 2 value. The meter resets and then displays present reading.		

18.

ANALOG OUTPUT

The analog output option provides a 0 to 20mA and a 0 to 10Vdc linear signal derived from the displayed reading. The low signal output and high signal output may be set to equal any displayed value. Although both outputs are available, only one is calibrated to specifications. The other output is accurate to +/-1% of the displayed value typical (2%max). To select which output is calibrated, set either current or voltage output from the menu, under **An Set**.

18.1 4 TO 20MA OUTPUT SCALING

The output is scaled by selecting a displayed value for the low signal output and a displayed value for the high signal output. For a current output, the low value is 0mA and the high output is 20mA. To scale a signal for 4 to 20 mA, the following procedure must be used:

1. Desired display value for 20mA - Desired display value for 4mA = Display span
2. Display span / 4 = Offset value
3. Desired display value for 4mA - Offset value = **An Lo**
4. **An Hi** = Desired display value for 20mA

18.2 ANALOG OUTPUT SETUP

The following menu items are accessible only with an Analog Output option installed and appropriate lockouts enabled. See Section 9 for further information. Setup Example: 4mA to 20mA out = 5000 counts to 15000 counts (See Section 18.2).

<div style="display: inline-block; border: 1px solid black; padding: 2px;"> MENU KEY MENU > </div>	<div style="display: inline-block; border: 1px solid black; padding: 2px;"> DIGIT SELECT KEY PEAK > </div>	<div style="display: inline-block; border: 1px solid black; padding: 2px;"> VALUE SELECT KEY RESET ^ </div>
<div style="text-align: center; border: 1px solid black; padding: 5px; font-size: 2em; margin-bottom: 10px;">An SET</div> <p>Press the MENU > key until An SET (Setup of analog output) is displayed. See section 9, An SET for detailed selection information.</p>	<div style="text-align: center; border: 1px solid black; padding: 5px; font-size: 2em; margin-bottom: 10px;">00</div> <p>Press PEAK > to display status. Press PEAK > again to select digit. Selected digit will flash.</p>	<div style="text-align: center; border: 1px solid black; padding: 5px; font-size: 2em; margin-bottom: 10px;">12</div> <p style="text-align: center; font-size: small;">1 2 3 4 5</p> <p>Press RESET ^ to select value for flashing digit. Digit 4: Current or Voltage Digit 5: Filtering</p>
<div style="text-align: center; border: 1px solid black; padding: 5px; font-size: 2em; margin-bottom: 10px;">An Lo</div> <p>Press the MENU > key until An Lo (Displayed value at 0mA or 0V) is displayed.</p>	<div style="text-align: center; border: 1px solid black; padding: 5px; font-size: 2em; margin-bottom: 10px;">00000</div> <p>Press PEAK > to display value. Press PEAK > again to select digit. Selected digit will flash.</p>	<div style="text-align: center; border: 1px solid black; padding: 5px; font-size: 2em; margin-bottom: 10px;">02500</div> <p>Press RESET ^ to select value for flashing digit</p>
<div style="text-align: center; border: 1px solid black; padding: 5px; font-size: 2em; margin-bottom: 10px;">An Hi</div> <p>Press the MENU > key until An Hi (Displayed value at 20mA or 10V) is displayed.</p>	<div style="text-align: center; border: 1px solid black; padding: 5px; font-size: 2em; margin-bottom: 10px;">00000</div> <p>Press PEAK > to display value. Press PEAK > again to select digit. Selected digit will flash.</p>	<div style="text-align: center; border: 1px solid black; padding: 5px; font-size: 2em; margin-bottom: 10px;">15000</div> <p>Press RESET ^ to select value for flashing digit</p>

19.

RS-232 AND RS-485 INTERFACE

19.1 OPERATING MODE MENU SELECTION

The following menu items are accessible only with an RS-232 or RS-485 option installed and appropriate lockouts enabled. See Section 8 for further information. Comprehensive details for using all of the serial output features are explained in the Micro Series Serial Communications Manual which is supplied on disk with the purchase of either a RS-232 or RS-485 board.

<div style="display: flex; justify-content: space-between; align-items: center;"> MENU KEY MENU > </div>	<div style="display: flex; justify-content: space-between; align-items: center;"> DIGIT SELECT KEY > PEAK </div>	<div style="display: flex; justify-content: space-between; align-items: center;"> VALUE SELECT KEY ^ RESET </div>
<div style="text-align: center; border: 1px solid black; background-color: black; color: white; padding: 5px; font-family: monospace; font-size: 1.2em; margin-bottom: 10px;">SEr 1</div> <p>Press the MENU > key until SEr 1 (Serial interface setup 1) is displayed.</p>	<div style="text-align: center; border: 1px solid black; background-color: black; color: white; padding: 5px; font-family: monospace; font-size: 1.2em; margin-bottom: 10px;">000</div> <div style="text-align: center; font-size: 0.8em; margin-bottom: 5px;">1 2 3 4 5</div> <p>Press > PEAK to display status. Press > PEAK again to select digit. Selected digit will flash.</p> <p>Digit 3: Output filtering Digit 4: Baud rate Digit 5: Output update rate</p>	<div style="text-align: center; border: 1px solid black; background-color: black; color: white; padding: 5px; font-family: monospace; font-size: 1.2em; margin-bottom: 10px;">158</div> <div style="text-align: center; font-size: 0.8em; margin-bottom: 5px;">1 2 3 4 5</div> <p>Press ^ RESET to select value for flashing digit</p> <p>Digit 3: "0"- Send unfiltered signal, "1"- Send filtered signal Digit 4: "0" to "6" (300 to 19200 baud) Digit 5: Line Freq. to 72.5 sec.</p>
<div style="text-align: center; border: 1px solid black; background-color: black; color: white; padding: 5px; font-family: monospace; font-size: 1.2em; margin-bottom: 10px;">SEr 2</div> <p>Press the MENU > key until SEr 2 (Serial interface setup 2) is displayed.</p>	<div style="text-align: center; border: 1px solid black; background-color: black; color: white; padding: 5px; font-family: monospace; font-size: 1.2em; margin-bottom: 10px;">0000</div> <div style="text-align: center; font-size: 0.8em; margin-bottom: 5px;">1 2 3 4 5</div> <p>Press > PEAK to display status. Press > PEAK again to select digit. Selected digit will flash.</p> <p>Digit 2: Line feed Digit 3: Alarm data sent with meter readings Digit 4: Control of output Digit 5: Meter address</p>	<div style="text-align: center; border: 1px solid black; background-color: black; color: white; padding: 5px; font-family: monospace; font-size: 1.2em; margin-bottom: 10px;">001E</div> <div style="text-align: center; font-size: 0.8em; margin-bottom: 5px;">1 2 3 4 5</div> <p>Press ^ RESET to select value for flashing digit.</p> <p>Digit 2: "0" - no line feed "1" - <LF> after <CR> Digit 3: "0" - no alarm data "1" - alarm data sent Digit 4: "0" - continuous output "1" - output on command Digit 5: "1" to "9" (Meter #1 to #9) "A" to "F" (Meter #10 to #15) "0." to "9." (Meter #16 to #25) "A." to "F." (Meter #26 to #31)</p>

19.2 JUMPER SELECTIONS

RS232 Interface

- Jumper g** - installed for normal operation
- Jumper h** - installed when used as a slave display with the RS232 output of another Micro Series meter.
- Jumper j** - provides a pull-up resistor on the RTS line.

Note: The board is shipped standard with jumpers **g** and **j** installed

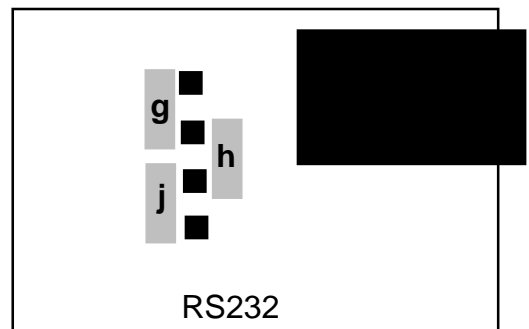

RS485 Interface

Note: Bias jumpers b and e must be installed on 1 board only for proper operation.

Full Duplex

Jumpers **b** and **e** - bias jumpers installed on 1 board
 Jumpers **a** and **d** - installed with long cable runs and adds 121 ohm resistorsto the the last meter in the line.

Half Duplex

Jumpers **b** and **e** - bias jumpers installed on 1 board
Jumpers c and f - installed for half duplex operation
Jumper a -installed with long cable runs and adds 121 ohm resistor to the the last meter in the line.

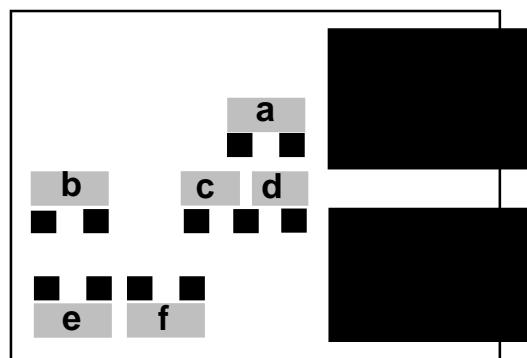

RS485

20.

PARALLEL BCD OUTPUT

20.1 OPERATING MODE MENU SELECTION

The following menu items are accessible only with a BCD option installed and appropriate lockouts enabled. See Section 8 for further information.

MENU KEY	DIGIT SELECT KEY	VALUE SELECT KEY
Press the key until SEr 1 (Serial interface setup 1) is displayed.	Press to display status. Press again to select digit. Selected digit will flash.	Press to select value for flashing digit
	Digit 3: Output filtering Digit 5: Output update rate	3: "0"-Send unfiltered signal "1"-Send filtered signal 5: "0"-Line frequency "1" to "9" - Batch display rate (3.5/sec) to Batch display rate / 256 (1 every 15 min.)

20.2 BCD OUTPUT LEVELS

The BCD option provides isolated, buffered, stored, 3-state parallel outputs that are selectable for either 0 to 5Vdc logic levels (LSTTL, CMOS compatible) or 0 to 15Vdc. Selection jumpers are located on the BCD board. BCD outputs are positive true. Polarity bit is positive true for +sign.

LOGIC LEVEL	JUMPER REQUIRED
0 to 5Vdc	b
0 to 15Vdc	a

20.3 BCD CONTROL SIGNALS

Enable Logical 0 - All outputs go to the high impedance state
 Logical 1 - BCD information is available at outputs.

BCD Hold Logical 0 - BCD from last update prior to BCD Hold going low is stored
 Logical 1 - BCD information updates at selected rate.

Data Ready Logical 0 - BCD outputs are valid
 Logical 1 - BCD outputs are not valid

21.

5, 10 AND 24 VDC EXCITATION OUTPUTS

Figure 21.1
 Power Supply

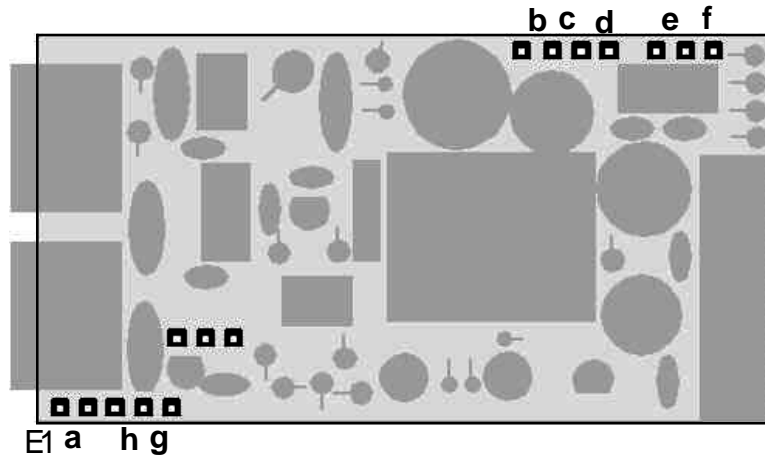

21.1 SELECTION OF 5, 10 OR 24VDC OUTPUT

Voltage Output	Jumper Locations
5 Vdc	b, d and e
10 Vdc	b, d and f
24 Vdc	c

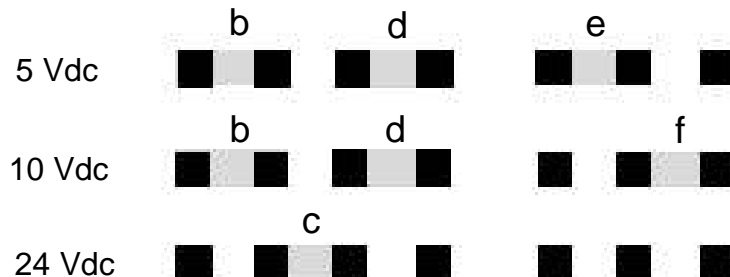

21.2 SELECTION OF OTHER JUMPERS

- Jumper ' a ' - Front panel menu lockout, locked when installed (see Section 8.1)
- Jumper ' g ' - Provides +5V power output at J1-4 when installed
- Jumper ' h ' - Connects "Digital Input B" to J1-4 when installed

21.3 MIGHTY-5 POWER SUPPLY

The Mighty-5 uses a switching power supply that operates from 85 to 264Vac or 90 to 370Vdc. See the diagram below when connecting power. This power supply is in addition to and works in conjunction with the J1 power supply shown in Section 21.1.

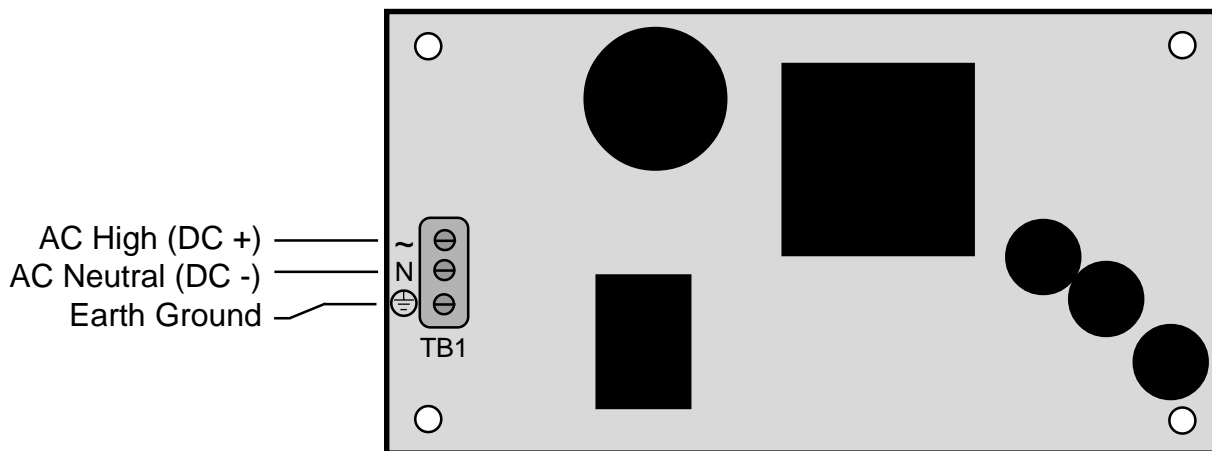

Signal Input and Excitation Outputs are connected to the Mighty-5 at J5. See Section 4 for connections.

Selection of Excitation Output 5V, 10V or 24V and the Menu Lockout are accomplished by jumpers on the J1 power supply. See Section 21.1. Unless specified at time of order, the Mighty-5 is shipped with 10Vdc Excitation Output selected.

22.

DIGITAL CONTROL INPUTS

22.1 FUNCTION OF DIGITAL INPUTS

Tare Logical 0 - The present display value is set to zero and stored as an offset value.
 Logical 1 - The displayed value is equal to the signal input minus the tare value.

Peak Display Logical 0 - The peak value of the input signal is displayed.
 Logical 1 - The present value of the input signal is displayed.

Hold Logical 0 - The meter display and outputs are held at the last reading.
 Logical 1 - The display and outputs are updated normally

Reset Logical 0 - The microcomputer reads and resets the meter to nonvolatile memory values
 Logical 1 - The meter display and outputs operate normally.

Function Reset Logical 0 - The microC resets peak to present value and resets alarms.
 Logical 1 - The meter display and outputs operate normally.

External Decimal Points	Digital Input A	Digital Input B	Decimal Pts 1	Decimal Pts 2
	1	1	XXXXX	XXXX.X
	0	1	XXXX.X	XXX.XX
	1	0	XXX.XX	XX.XXX
	0	0	XX.XXX	X.XXXX

22.2 MENU SELECTIONS

MENU KEY	DIGIT SELECT KEY	VALUE SELECT KEY																
Press the key until SETup (Basic meter setup) is displayed.	Press to display status. Press again to select digit. Selected digit will flash. Digit 5: digital inputs A & B are located at J1, pins 4 & 5.	Press to select value for flashing digit <table style="width: 100%; border: none;"> <tr> <td>0 A: Reset</td> <td>B: Hold</td> </tr> <tr> <td>1 A: Func. Reset</td> <td>B: Peak</td> </tr> <tr> <td>*2 A: Meter Hold</td> <td>B: Peak</td> </tr> <tr> <td>*3 A: Meter Hold</td> <td>B: Tare</td> </tr> <tr> <td>*4 A: Peak</td> <td>B: Tare</td> </tr> <tr> <td>5 A: Tare</td> <td>B: Reset</td> </tr> <tr> <td>6 External Decimal, DP1</td> <td></td> </tr> <tr> <td>7 External Decimal, DP2</td> <td></td> </tr> </table>	0 A: Reset	B: Hold	1 A: Func. Reset	B: Peak	*2 A: Meter Hold	B: Peak	*3 A: Meter Hold	B: Tare	*4 A: Peak	B: Tare	5 A: Tare	B: Reset	6 External Decimal, DP1		7 External Decimal, DP2	
0 A: Reset	B: Hold																	
1 A: Func. Reset	B: Peak																	
*2 A: Meter Hold	B: Peak																	
*3 A: Meter Hold	B: Tare																	
*4 A: Peak	B: Tare																	
5 A: Tare	B: Reset																	
6 External Decimal, DP1																		
7 External Decimal, DP2																		
* Selections 2, 3, and 4: With A & B both low (grounded), the meter will Function Reset.																		

23.

MECHANICAL ASSEMBLY, MICRO-P & MIGHTY-1

23.1 REMOVING THE REAR PANEL

To remove the rear panel, first remove any connectors that are installed. Micro-P: Press down on both rear panel retaining tab releases (see Fig. 23.1) and pull the top of the rear panel away from the case. The bottom of the rear panel will now lift out. Mighty-1: Remove the 6 screws holding the back plate in place and pull the rear panel away from the case.



23.2 Removing the meter from the case

After removing the rear panel, the meter can be taken out of the case by carefully grasping the power supply board and signal conditioner board at the connectors and sliding the unit out the back of the case. See Figure 23.2.

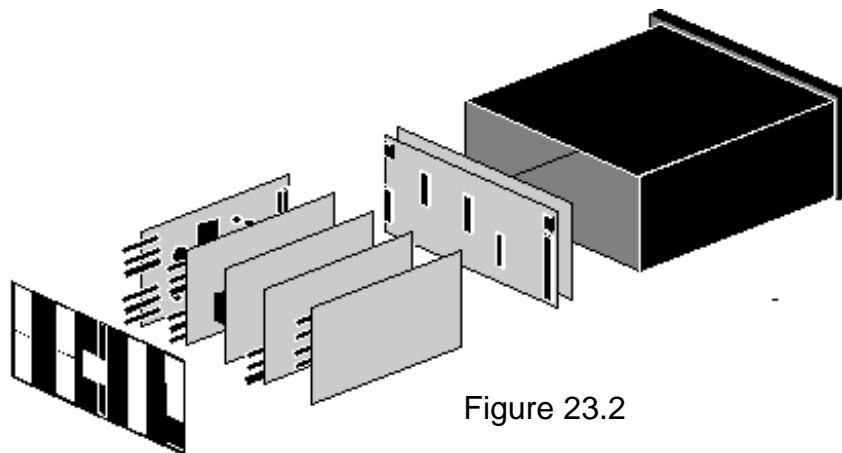

23.3 REASSEMBLING THE METER

Reverse the preceding procedures to reinstall the meter in the case. Micro-P: After the meter is in the case, insert the bottom tabs on the rear panel into the case first. Mighty-1: Replace the rear panel with the 6 screws. For both meters, care must be taken to ensure the printed circuit boards are properly aligned by the board retaining pins on the inside of the rear panel.

24.

MOUNTING AND DIMENSIONS, MICRO-P & MIGHTY-1

Be sure the gasket to mount the case to the panel is in place. Micro-P: Turn the two mounting screws counterclockwise until the space between the mounting pawl and the bezel is greater than the panel thickness. Insert the meter in the panel cutout. Turn the mounting screws clockwise until the meter is securely mounted in the panel. Do not overtighten the mounting screws. Mighty-1: Facing the rear of the meter and using a small hex-key wrench, remove the two set-screws that hold the slides on the sides of the meter. Insert the meter into the panel cutout, install the two slides and set-screws and tighten the set-screws to retain the meter in the panel.

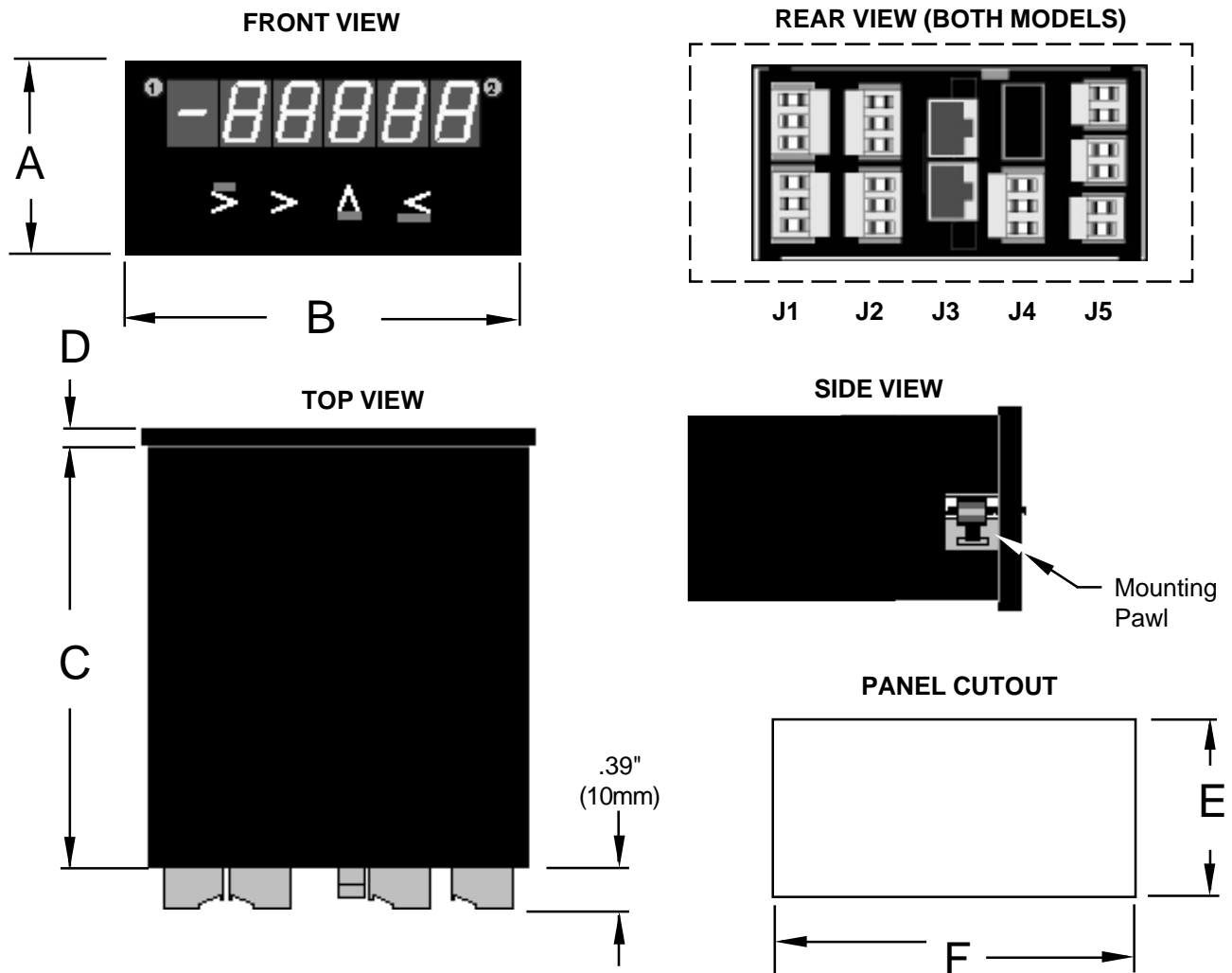

	MICRO-P	MIGHTY-1
A	1.89" (48mm)	3.78" (96mm)
B	3.78" (96mm)	7.56" (192mm)
C	4.02" (102mm)	3.80" (96.5mm)
D	.197" (5mm)	.50" (13mm)
E	1.772" +.024/-0.0" (92+0.8/-0.0mm)	3.560" +.03/-0.0" 90.4+0.8/-0.0mm
F	3.622" +.032/-0.0" (92+0.8/-0.0mm)	7.23" +.03/-0.0" 184+0.8/-0.0mm

25.

MECHANICAL ASSEMBLY, MIGHTY- 4

25.1 OPENING THE CASE

To remove the display board assembly from the case, loosen the outside nut on the cable feed-through located on the end of the case so the cable is free to move. Remove the (8) bezel screws from the bezel. Remove the bezel and window. Using a 1/4" nut driver, remove the (8) hex spacers. The display board assembly may now be removed from the main portion of the case.

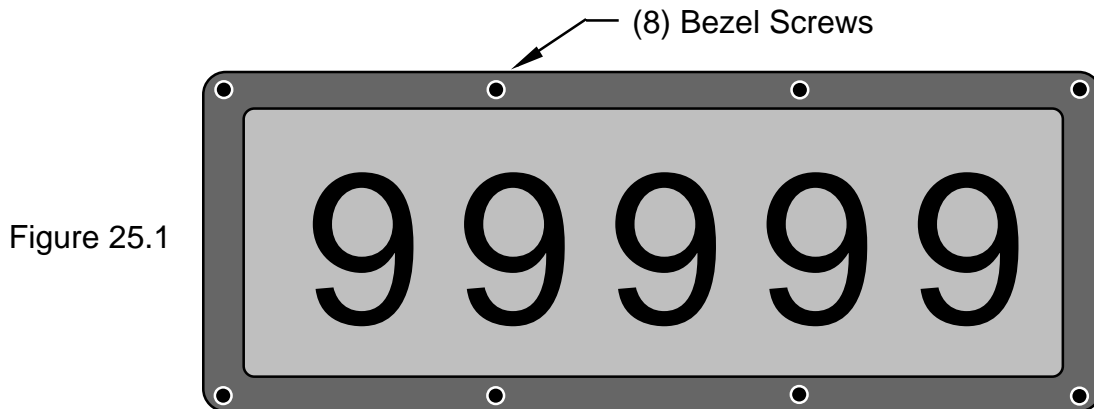

25.2 ACCESSING THE WIRING CONNECTORS

After removing the display board assembly, all plug-in boards and their wiring connectors are accessible. Boards may be added or deleted by first removing the plug-in wiring connectors and then the (4) screws securing the module hold-down board. See Figure 25.2.

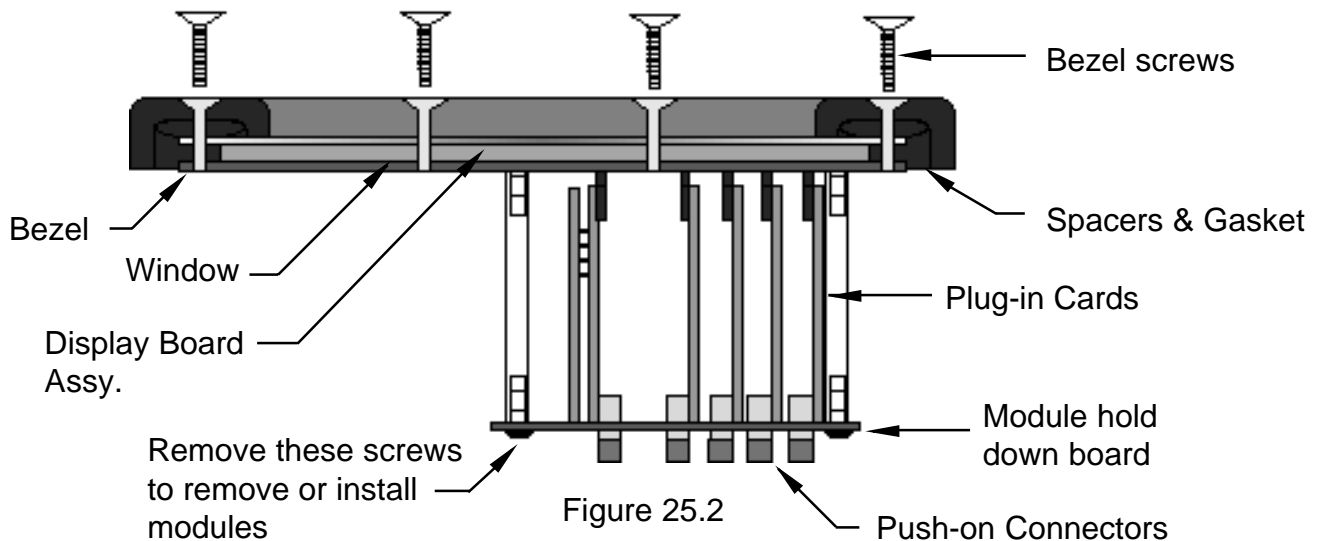

25.3 REASSEMBLING THE DISPLAY

Reverse the preceding procedures to reassemble the case. First install the display board assembly and the (8) hex spacers. Next install the window and bezel with the (8) bezel screws. Care must be taken to ensure the printed circuit board, window and gasket are properly aligned with the (8) mounting screws holes in the bezel assembly.

26.

MECHANICAL ASSEMBLY, MIGHTY- 5

NOTE: To make setup changes to the display using the display board mounted pushbuttons, (see Section 5) it is necessary to remove the display board assembly from the case.

26.1 OPENING THE CASE

To remove the display board assembly from the case, loosen the outside nut on the cable feed-through located on the end of the case so the cable is free to move. Remove the (16) rear panel screws from the rear of the case. Remove the rear panel. Using a 3/8" nut-driver, remove the (16) hex nuts holding the display assembly to the window studs. The display board assembly may now be removed from the main portion of the case.

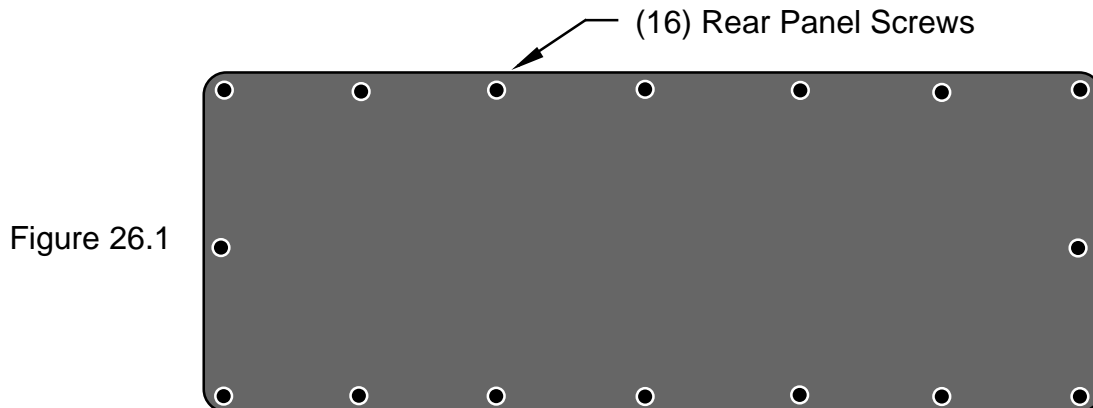

26.2 ACCESSING THE WIRING CONNECTORS

After removing the display board assembly, all plug-in boards and their wiring connectors are accessible. Boards may be added or deleted by first removing the plug-in wiring connectors and then the (4) screws securing the module hold-down board. See Figure 26.2.

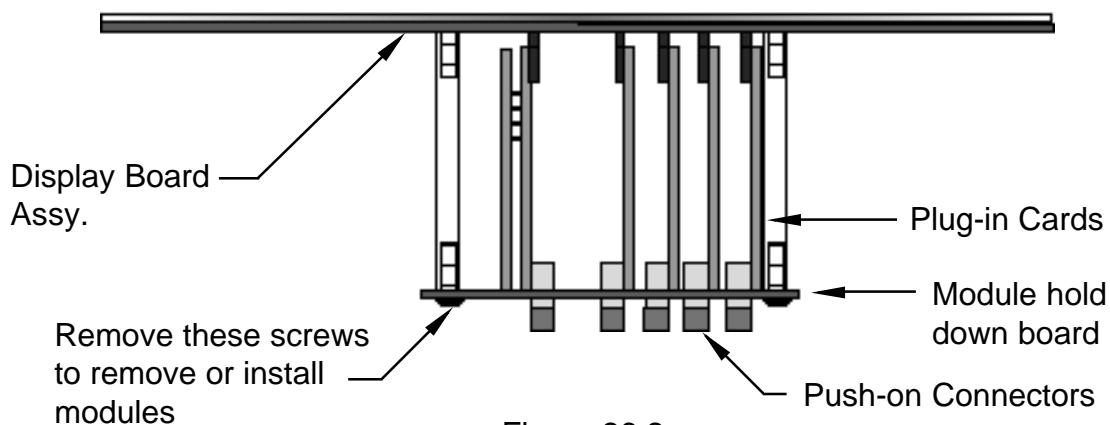

26.3 REASSEMBLING THE DISPLAY

Reverse the preceding procedures to reassemble the case. First install the display board assembly and the (16) hex nuts, do not over-tighten. Next, using the (16) rear panel screws, install the rear panel being careful that the gasket remains in place.

27.

MOUNTING AND DIMENSIONS, MIGHTY-4 & MIGHTY-5

Mighty-4: For panel mounting, remove the panel mount bail and bail clamp screws. Install the display through panel cutout. Using the rear screw insert positions, replace the panel mount bail and bail clamp screws and secure the panel mount bail firmly against the back of the panel. Do not over tighten the bail clamp screws. For wall mounting, use the side screw insert positions. The bail may be used to adjust the viewing angle of the display as shown below. Mighty-5: If ordered with rear panel mounting, the mounting holes in the rear panel may be used to mount the display to a wall or panel. If optional mounting brackets were ordered, they may be used to adjust the viewing angle of the display when mounted to a wall or ceiling. If ordered with an indoor plastic case, the same mounting methods may be used as for the Mighty-4.

MIGHTY-4 (and **MIGHTY-5** with the plastic case mounting option).

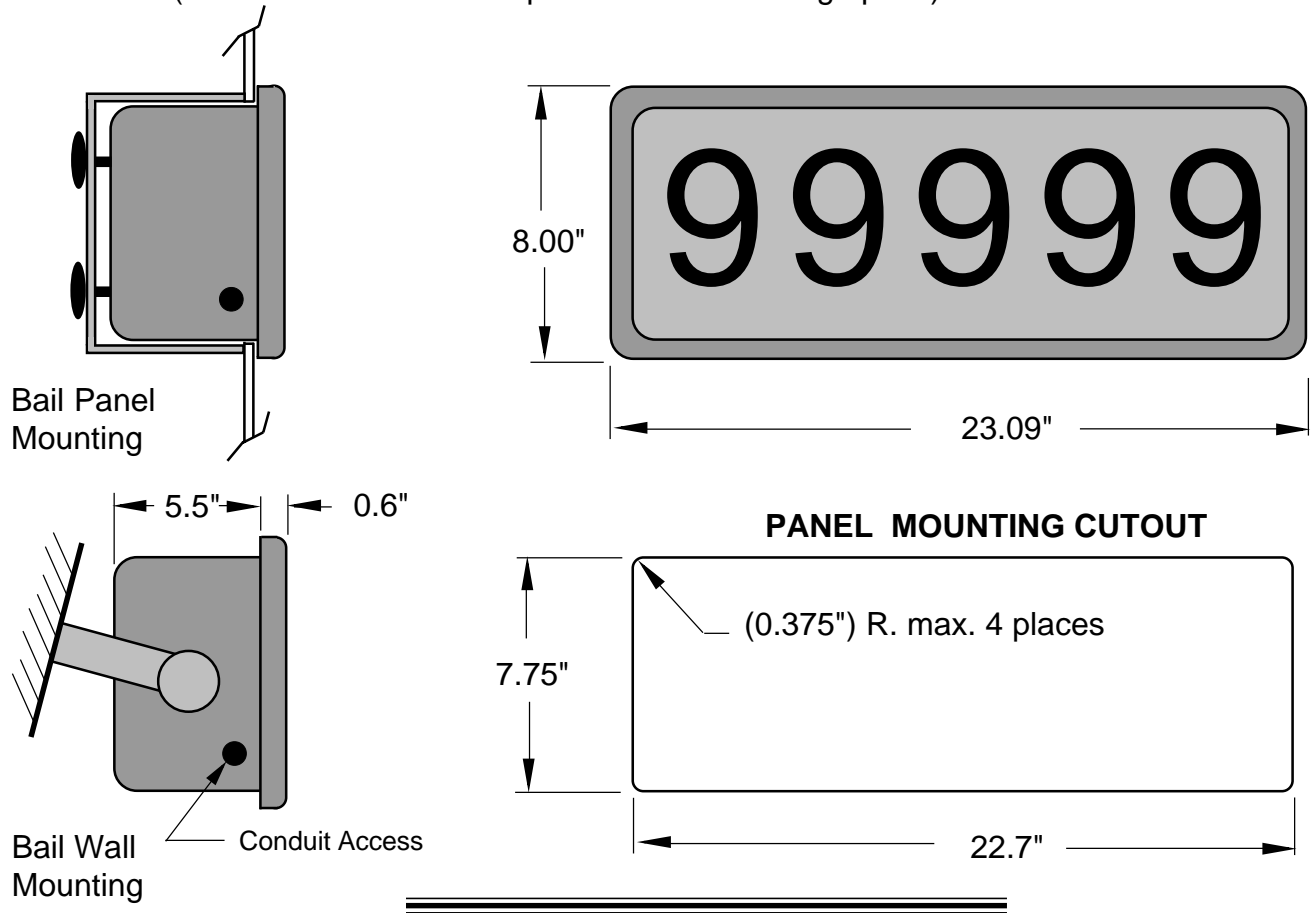

MIGHTY-5 (with NEMA-4X case)

Option 1: Surface Mount Back Panel

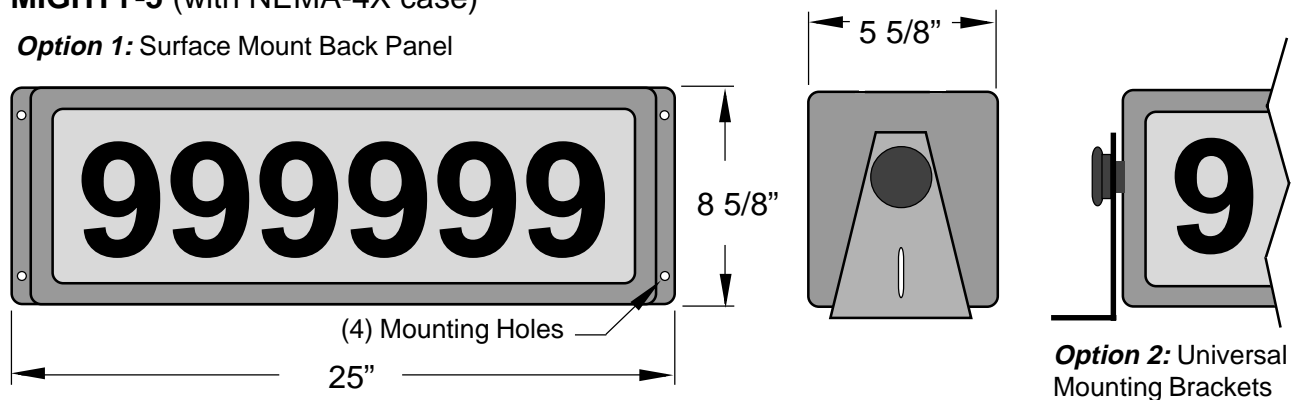

28.

CONNECTORS, ALL MODELS

The Micro Series displays use UL/VDE rated screw terminal connectors that plug into mating jacks on the plug-in modules.

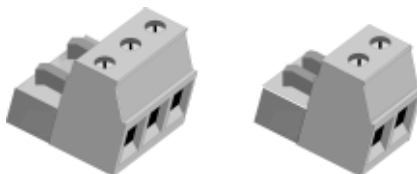

29.

CALIBRATION

All ranges of the displays have been digitally calibrated at the factory and are stored in non-volatile memory. This provides superior long term accuracy and stability while eliminating much of the analog circuitry that causes drift. The calibration equipment is certified to NIST standards. Since the calibration is stored on the signal conditioner and analog output boards, all boards (within the same date-code series) may be mixed and interchanged without requiring recalibration. If recalibration is required, the meter may be returned to Electro-Numerics or any authorized Electro-Numerics distributor.

30.

SPECIFICATIONS

BASIC METER

Display

- Type (Micro-P) 5 LED digits, 7-segment, 14 mm (.56") high digits & 2 LED indicators
- Type (Mighty-1) 5 LED digits, 7-segment, 25 mm (1.0") high digits & 2 LED indicators
- Type (Mighty-4) 5 LED digits, 7 segment, 102 mm (4.0") high digits & 2 LED indicators
- Type (Mighty-5) 5 outdoor LED digits, 7 segment, 127mm (5.0") high & 2 LED Indicators
- Color Red on Mighty-1, Mighty-4 & Mighty-5, Green or Red on Micro-P
- Range -99999 to +99999 and -99990 to +99990

A to D Conversion

- Rate 60/s for 60 Hz NMR, 50/s for 50 Hz NMR
- Output Update Rate 56/s at 60 Hz, 47/s at 50 Hz
- Display Update Rate 3.5/s at 60 Hz, 3/s at 50 Hz

Noise Rejection

- CMV from DC to 60 Hz Safety-rated to 250Vac, 4.2kVp per High Voltage Test
- CMR from DC to 60 Hz 130 dB
- NMR at 50/60 Hz 90 dB with minimum digital filtering

External Inputs/Outputs (CMOS/TTL Levels)

- Hold input 0 - holds display and outputs
- Peak input 0 - displays peak value
- Tare input 0 - offsets input value to zero
- Reset input 0 - resets all meter functions
- Function Reset input 0 - resets peak values and alarms
- Decimal Point input Overrides internal DP selections and controls DP position

ACCURACY

DC Volts

VOLTAGE RANGE	RESOLUTION	INPUT OHMS	ERROR AT 25°C
200.00 mV	10 uV	1 G	.01% Full Scale +/-2 Ct.
2.0000 V	100 uV	1 G	
20.000 V	1 mV	1 M	
200.00 V	10 mV	1 M	
660.0 V	100 mV	1 M	

DC Amperes

CURRENT RANGE	RESOLUTION	INPUT OHMS	ERROR AT 25°C
2.0000 mA	0.1 uA	100	.01% Full Scale +/-2 Ct.
20.000 mA	1.0 uA	10	
200.00 mA	10 uA	1	
5.000 A	1.0 mA	.01	

Ratio

VOLTAGE RANGE	RESOLUTION	INPUT OHMS	ERROR AT 25°C
200.00 mV	10 uV	1 G	.01% Full Scale +/-2 Ct.
2.0000 V	100 uV	1 G	
20.000 V	1 mV	1 M	

True RMS Volts (1 to 100% Full Scale)

VOLTAGE RANGE	RESOLUTION	INPUT OHMS	ERROR AT 25°C
200.00 mV	10 uV	22 M	.1% FS +/-10 Ct. from 10 Hz to 10kHz
2.0000 V	100 uV	22M	
20.000 V	1 mV	1 M	
200.00 V	10 mV	1 M	
660.0 V	100 mV	1 M	

True RMS Amperes (1 to 100% Full Scale)

CURRENT RANGE	RESOLUTION	INPUT OHMS	ERROR AT 25°C
2.0000 mA	0.1 uA	100	.1% FS +/-10 Ct. from 10 Hz to 10kHz
20.000 mA	1.0 uA	10	
200.00 mA	10 uA	1	
200.00 mA	10 uA	1	
5.000A	.25 mA	.01	

RTD's (.01, .1, 1.0 Degree Resolution)

PT100 TYPE	RANGE	ERROR AT 25°C
DIN .00385	-202°C to +850°C -331°F to +1562°F	.01% FS +/- 0.03°C .01% FS +/- 0.05°F
ANSI .003925	-202°C to +631°C -331°F to +1168°F	.01% FS +/- 0.04°C .01% FS +/- 0.07°F

Thermocouple

(.1, 1.0 Degree Resolution)

TC TYPE	RANGE	ERROR AT 25°C
J	-210°C to +760°C -347°F to +1400°F	.01% FS +/- 0.09°C .01% FS +/- 0.16°F
K	-244°C to +1372°C -408°F to +2501°F	.01% FS +/- 0.1°C .01% FS +/- 0.17°F
T	0°C to +400°C -257°C to 0°C +32°F to 752°F -430°F to +32°F	.01% FS +/- 0.03°C .01% FS +/- 0.2°C .01% FS +/- 0.05°F .01% FS +/- 0.36°F
E	-240°C to +1000°C -400°F to +1830°F	.01% FS +/- 0.18°C .01% FS +/- 0.32°F
N	-244°C to +1372°C -408°F to +2501°F	.01% FS +/- 0.1°C .01% FS +/- 0.17°F
S	-46°C to +1768°C -51°F to +3213°F	.01% FS +/- 0.12°C .01% FS +/- 0.22°F
R	-45°C to +1768°C -49°F to +3214°F	.01% FS +/- 0.17°C .01% FS +/- 0.31°F

Load Cell Inputs

INPUT RANGE	RESOLUTION	OUTPUT ZERO RANGE	OUTPUT SPAN RANGE	ERROR AT 25°C
20.000 mV	1 uV	-99,999 to +99,999	0 to +/-99,999	.01% Full Scale +/-1Ct.
50.000 mV	2.5 uV			
100.00 mV	5 uV			
250.00 mV	12.5 uV			
500.00 mV	25 uV			

Span Tempco	0.003% of reading/°C
Load Cell Meter only	0.0015% of reading/°C
Zero Tempco	0.2 μ V/°C
Reference Junction	0.03 degree/degree

POWER SUPPLIES

Input Voltage (standard)	85 to 264 Vac, 90 to 370 Vdc
Input Voltage (optional except Mighty-5)	8 to 28 Vac, 9 to 37 Vdc
Frequency	DC and 47 to 440 Hz
Power Consumption	6 Watts max. (Micro-P, Mighty1), 9 Watts max. (Mighty4), 28 Watts max. (Mighty-5)
Excitation Power Supplies	
Outputs	5 Vdc, 5%, 100 mA max 10 Vdc, 5%, 120 mA max. 24 Vdc, 5%, 40 mA max.
Ripple	100 mVp max.
Isolation	Safety-rated to 250Vac, 4.2kVp per High Voltage Test

DUAL CONTROLLER OPTION

Basic

Power	Provided by basic meter
Update Rate	56/s at 60 Hz, 47/s at 50 Hz
Setup	setpoint values may be entered by front panel pushbuttons or via RS-232 or RS-485
Lockouts	Front panel pushbuttons control display and change of setpoints, only control display of setpoints, or are disabled.
Output Operation	either output may be set to operate above, below or around the setpoint, latching or non-latching or output disabled
Filtering	comparison to the setpoints may be either from the filtered or unfiltered input signal
Time Delay	selectable time delay of output status change of 1 to 128 readings
Hysteresis	selectable from 0 to +/- 99,999 counts

Alarm Status Indicators

Type	2 red LED lamps
------------	-----------------

Relay Output

Contact Rating	10 A @ 240 Vac, 8 A @ 24 Vdc
Safety Certification	VDE, UL, and CSA (Micro-P model only)

Isolation

Coil to Contacts Safety-rated to 250Vac, 4.2kVp per High Voltage Test
Between Open Contacts withstand 4.2kVp for 1 min
Pickup 26 ms typ.
Release 22 ms typ.

Solid State Relay Output

Voltage Rating 125Vac, 150 Vdc max.
Current Rating 120 mAac, 240mAdc
Safety Certification VDE, UL and CSA
Isolation Safety-rated to 250Vac, 4.2kVp per High Voltage Test
Response to input signal 17 ms typ.

ANALOG OUTPUT OPTION

Isolation Safety-rated to 250Vac, 4.2kVp per High Voltage Test
Power supplied by basic meter
Accuracy basic meter +/-0.1% Analog Full Scale
Response Time 17 ms for unfiltered input, same as basic meter for filtered input
Compliance
 0 to 20 mA 12 V (0 to 600 Ohms)
 0 to 10 V 2 mA (5 kOhms min.) load
Scaling
Reading for Zero Output -99,999 to +99,999
Reading for Full Scale Output -99,999 to +99,999

RS-232 / RS-485 INTERFACE OPTION

Isolation Safety-rated to 250Vac, 4.2kVp per High Voltage Test
Power supplied by basic meter
Type full or half duplex (RS-485)
Baud Rates 300, 600, 1200, 2400, 4800, 9600, 19200
Signal Levels Meet RS-232 and RS-485 standards

BCD OUTPUT OPTION

Isolation Safety-rated to 250Vac, 4.2kVp per High Voltage Test
Power supplied by basic meter
Type 3-state, stored, parallel
Signal Levels LSTTL, CMOS compatible
Controls BCD Enable, $\overline{\text{Hold}}$, $\overline{\text{Data Ready}}$

ENVIRONMENTAL

Operating Temperature 0°C to 55°C
Storage Temperature -40°C to 85°C
Relative Humidity 90% from 0°C to 40°C

31.

Electro-Numerics Inc. Products

Electro-Numerics family of Digital Panel Meters and Large Digit Indicators are high quality, accurate, solid state instruments designed for years of trouble free operation. Over 29 years of digital instrumentation experience has resulted in a series of displays recognized in the field as reliable, well designed instruments. From our compact sized DPM's with 0.56" LED digits to our Large Digit indicators with 1", 2 1/4", 4" & 5" LEDs or 4", 6" & 9" tall electromagnetic digits, we cover most applications in process measurement and display. For full product information and prices, visit our web site at www.ElectroNumerics.com.

Warranty (2 Years)

Electro-Numerics, Inc. warrants these products to be free in defects in workmanship and materials for two years from the date of shipment to the original customer. This warranty on workmanship and materials may be considered as unconditional provided that, in the opinion of Electro-Numerics, Inc., the equipment has not been mechanically, environmentally, or electrically abused and has been installed, maintained and operated within the limits of rated or normal usage.

Defective products must be sent, transportation charges prepaid with notice of the defect, to our plant in Temecula, CA.

This warranty is limited, at the option of Electro-Numerics, Inc., to repair, replacement, or an appropriate credit adjustment not to exceed the original equipment sales price. All warranty freight charges are F.O.B. our plant, Temecula, CA.

Electro-Numerics, Inc. assumes no responsibility in connection with the sale of its products beyond that stated above and is not responsible for any incidental or consequential loss or damage which might result from a failure of any Electro-Numerics, Inc. product.

Repair Policy

Direct all warranty and out-of-warranty requests/inquiries to Electro-Numerics, Inc., Customer Service Repair Dept., telephone: 800-854-8530 (U.S.A.) or 951-699-2437, Fax: 951-695-7246, Email: Sales@ElectroNumerics.com. Repair work will be handled at the factory or an authorized Electro-Numerics, Inc. repair service center.

All items sent in for service are subject to a minimum evaluation charge of \$60.00 in the event that the product is found to be out-of-warranty or, if under warranty, not in need of additional service. Out-of-warranty service and repair charges will be quoted on a case by case basis. All repaired products will be shipped to you F.O.B., Temecula, CA.

There are three methods of scaling the meter. Method 1 reads the values when the meter is connected to a sensor or transducer. Method 2 uses Scale Factor and Offset ($MX + b$), see SCALE and OFFSET below. Method 3 uses Coordinate of Two Points. Methods 2 and 3 do not require that the meter be connected to a sensor or transducer and the scaling information is usually supplied from the sensor's calibration certificate.

Coordinates of Two Points With this method of scaling (Method 3), you enter known values for zero and full scale. For example if the meter is connected to a 4/20mA pressure sensor for a reading of 0 to 100.0 PSI, you would input 4mA = 000.0 and 20 mA = 100.0.

Note: Method 2 (Scale Factor and Offset) is the default method of scaling shipped from the factory.

Scale With this method of scaling (Method 2), you enter calculated values for Scale (scale factor) and Offset (at zero). The scale factor may be set from +/-0.0001 to +/-9.9999. When scale is selected, the most significant digit flashes allowing the value of that digit to change, pushing the digit select key moves the flashing digit to the right. When the right hand digit is flashing, pushing the digit select key again causes the decimal point to be displayed. Pushing the value select key changes the location of the decimal point. When decimal XXXXX. is reached, the next time the digit select key is depressed, the display goes back to the scale factor.

Offset Offset is used in conjunction with Scale above. An offset value from -99,999 to 99,999 may be entered in the offset menu item to be used to offset the zero point.

Deviation Applies to Setpoint Alarms. Either alarm may operate in the deviation mode. In the menu item "dEU1b & dEU2b", a value is entered equivalent to the amount above and below the setpoint at which the alarm operates. For example, if the value entered is 100, and the setpoint value is 1000, the alarm would energize above 1100 and below 900.

Hysteresis Applies to Setpoint Alarms. Either alarm may operate in the hysteresis mode. In the menu item "dEU1H & dEU2H", a value is entered equivalent to the amount above and below the setpoint at which the alarm operates. For example, if the value entered is 10, and the setpoint value is 1000, if the alarm is set to energize above the setpoint, the alarm would energize above 1010 would not deenergize until the displayed value goes below 990. This mode reduces relay chatter and excessive cycling of the load.

Auto filtering This filtering method looks at the input signal for +/- variations. The larger the deviations, the greater the filtering applied. The amount of filtering is automatic and based on the moving average chart following.

Auto Filtering Continued:

TIME	READINGS AVERAGED
0.08 sec	2
0.15 sec	4
0.30 sec	8
0.60 sec	16
1.20 sec	32
2.40 sec	64
4.80 sec	128
9.60 sec	256

Batch averaging, 16 rdgs. There are two BATCH AVERAGING listings, one under DISPLAY FILTERING and the other under INPUT SIGNAL FILTERING. They both operate in the same manner however the one for DISPLAY FILTERING pertains only to the display while the other operates on all other functions listed as filtering either on or off, such as the analog output and peak signal. The meter accumulates 16 readings, averages them and displays the results or sends the results to the output board. When finished, the result is cleared and the process begins again with another 16 readings. There is no moving averaging associated with this type of filtering.

Moving average Assume the INPUT SIGNAL FILTERING is set to 4. This relates to a moving average of 8 readings. The meter will take 1/8 of the new reading and add it to the previous moving average, then average it again which becomes the new moving average. This process continues until the MOVING AVERAGE selection is changed.

Unfiltered input When unfiltered is selected, the meter will process information at approximately 56 readings per second. If filtering is selected, the processing rate will be slower than 56 readings per second dependent on the amount of filtering used.

Calibration CALIBRATION should not be confused with the term SCALING. CALIBRATION of the meter is done at the factory where calibration values are entered into memory locations to compensate for factors such as component tolerance, etc. This provides superior long term accuracy and stability while eliminating much of the analog circuitry that causes drift. To perform CALIBRATION requires factory equipment and software. See SCALING.

Scaling Scaling of the meter can be accomplished by the user with or without sophisticated laboratory standards. Scaling uses the meter's menu that allows setting of all parameters such as zero offset, full scale readings, analog output values, etc. In other words all of the parameters of the meter are accessible to the user to make the meter function in the manner required. These functions are listed under SETUP, Section 9 of this manual.



ELECTRO-NUMERICS, INC

42213 Sarah Way, Temecula CA 92590

Tel (U.S.A.): **800-854-8530** or 951-699-2437

Fax: 951-695-7246

Email: Sales@ElectroNumerics.com, Internet: www.ElectroNumerics.com