

# *The MICRO SERIES* **COUNTERS & TIMERS**

## **LARGE DIGIT MODEL**

**Mighty-5C**



## **DPM MODELS**

**Micro-C & Mighty-1C**



**Mighty-1C**



**Micro-C**



**ELECTRO-NUMERICS, INC.**

# Introduction

The Electro-Numerics family of Digital Panel Meters and Large Digit Displays are accurate, solid state instruments designed for years of trouble free operation. Since 1974 we have been manufacturing quality products designed to meet the needs of our customers. Our displays are recognized in the industry as reliable, well designed instruments. From our compact sized 1/8<sup>th</sup> DIN Digital Panel

Meters with 0.56" Led digits to our Large Digit Displays with digit sizes from 1" to 9" viewable to 360 feet, we cover most applications in process measurement and display. This catalog describes our Micro Series of microprocessor-based display/controllers. Contact the factory or your local distributor for a catalog on our other display products.

## Electro-Numerics' Products

### Digital Panel Meters



Micro-C Digital Panel Meter (DPM) with 0.56" Tall Led Digits

Digital Displays with 0.56" Led digits provided in a 1/8 DIN (96 x 45mm) panel mount case. These units are compatible with most sensors and can be scaled to read in engineering units.

### Large Digit Displays



Remote Displays, Counters, Timers and Process Displays

Our family of Large Digit Displays includes many models with digit sizes ranging from 1" Led's to 9" tall electromagnetic characters. The Micro Series large digit displays covered in this catalog, includes the Mighty-1C with 1.0" digits readable at 40 feet and the Mighty-5C with superbright outdoor-readable digits readable at 200 feet.



Mighty-5C Counter/Timer with 5" Tall Outdoor Led Digits

Please visit our Web Site at: <http://www.Electronumerics.com>

Call: **1-800-854-8530** or Fax: 951-695-7246 for Applications Assistance

# The Micro Series

## MICRO-C MIGHTY-1C MIGHTY-5

6 Digit (999,999) Counters & Timers  
Choice of .56" or 1.0" Indoor or Superbright, 5.0" Outdoor LED Digits



**Micro-C** with 0.56" Led Digits



**Mighty-1C** with 1" Indoor Led Digits



**Mighty-5C** with 5" Outdoor Led Digits

### FEATURES

- **Bright Displays with 6 Digits (999,999) :**  
*Micro-C:* 0.56" red or green Led's  
*Mighty-1C:* 1" red Led's. 40' visibility  
*Mighty-5C:* 5" red outdoor Led's. 200' visibility
- **Three signal conditioner input cards:**  
*Analog Signals* (0/10V or 4/20mA) for rate or square root of rate.  
*Dual Channel* for pulse or frequency inputs with independent scaling for each channel. Displays rate, total, period, time interval and phase angle.  
*Quadrature* for use with position encoders to display distance.
- **Stopwatch Timer** with clock display to 55 hours
- **Worldwide Power**, 85-264 Vac & 90-370 Vdc
- **Excitation:** 5, 10 or 24 Vdc to power sensors
- **Scalable** in engineering units with programmable decimal points, leading zero blanking and one or two dead zeros (999,990 or 999,900)
- **Easy Setup** by push-buttons or computer
- **Digital Input Remote Displays** with RS232 or RS485 communications

### PLUG-IN OPTIONS

- **Low Voltage Power**, 9 to 37 Vdc & 8 to 28 Vac (except Mighty-5C)
- **Analog Outputs**, 0-10 Vdc or 0-20 (4/20) mAdc
- **RS485, RS232 or Parallel BCD Outputs**
- **Dual Setpoints**, relay or isolated open collector

### COUNTER CONFIGURATIONS

The Micro-C, Mighty-1C and Mighty-5C models are offered in both a standard and extended version. The extended version offers advanced features such as simultaneous measurements of rate and total, linearizing of non-linear signal inputs, mathematical functions such as A channel plus B channel (A + B), stopwatch and phase angle measurements. The basic counter version may be used to measure rate, square root of rate (flowmeters), frequency, total, period and quadrature.

See the Ordering Guide on page 9 and the following descriptions to determine which version you require for your application.

#### BASIC COUNTER:

##### *With Dual Channel Counter Signal Conditioner:*

- Rate:** Channel A or A & B simultaneously
- Period:** Channel A or A & B simultaneously
- Total:** Channel A or A & B simultaneously
- Time Interval:** Measure a time period, Channel A = Start and channel B = Stop
- Frequency:** Channel A or A & B simultaneously
- Square Root:** Can be displayed with all rate functions.

##### *With Voltage to Frequency (V/F) Signal Conditioner:* (Single Channel A only)

- Analog current:** 4/20 mA
- Analog current:** 0/1 mA
- Analog voltage:** 0/10 V
- Analog voltage:** 0/100 mV
- Rate of Channel A or Square Root of Rate

##### *With Quadrature Signal Conditioner:*

**Quadrature input:** Measures position or length when used with encoders either differential or single-ended and 1X, 2X or 4X inputs. Displays a displacement based on the inputs from channels A and B with a correction signal from the encoder connected to the Z input.

## EXTENDED COUNTER

### **With Dual (Channel A & B) Signal Conditioner:**

See page 7 for setup options.

**Rate:** Calculates rate or rate & total for combinations of signals on channels A and B, as well as batching and mathematical functions.

**Period:** Calculates period for combinations of signals on channels A and B, as well as mathematical functions.

**Total:** Calculates total (counts) for combinations of signals on channels A and B, as well as mathematical functions.

**Stop watch:** Display in clock mode (hrs.min.sec.) or standard display mode (999999) with a start and stop on A or start on A and stop on B.

**Phase Angle:** Phase angle between signals on A and B and displays in degrees.

**Square Root:** can be displayed with all of the above rate functions

These displays take up to 60 readings per second for fast control response, true peak reading capability, and an analog output that accurately tracks the signal input. An adaptive digital filter that can automatically select the best time constant for minimum noise yet respond rapidly to signal input changes is standard. The peak value of the input signal can be displayed by a push of a button on the front panel and push-button tare allows the meter display to be set to zero for any input signal level. The Micro-Series provides isolated 5, 10, or 24 Vdc output to power strain gauges and transmitters, eliminating the need for an external supply.

These displays have two alarm indicators with the setpoints programmed by front panel push-buttons. Option cards with dual open collector transistors or 10 amp form-C relays may be added to provide control outputs. The outputs can be set to operate above or below the setpoints in a latched or non-latching mode and with band deviation. Analog Outputs of 0 to 10 V or 0 to 20 mA (4/20 mA) are available to drive chart recorders, remote displays or for transmission to a central control room.

## EXTENDED COUNTER

### **With Voltage to Frequency (V/F) Signal Conditioner:**

(Single Channel A)

**Analog current:** 4/20 mA

**Analog current:** 0/1 mA

**Analog voltage:** 0/10 V

**Analog voltage:** 0/100 mV

Calculates rate (speed); rate and totals simultaneously; rate, total and batch and inverse of rate. The display may be scaled (+/-999,999 maximum) to read in engineering units.

### **With Quadrature Signal Conditioner:**

Quadrature Rate and Distance

The outputs are scaled through the front panel push buttons.

Adding RS-232 or RS-485 enables the displays to communicate with PLC's or computers. Baud rates can be set from 300 to 19,200. Configuration software provided with these options makes meter setup even easier. Three state, parallel BCD outputs are also available.

The Micro Series can be provided in an extended operating mode. With an extended version computer/display module installed, these displays may be programmed to *linearize nonlinear signal inputs* and will provide additional features as described above.

Windows based data logging and monitoring software is available for connection of 1 to 32 meters with a serial communications card installed. This software allows monitoring the process values, setpoints and peak values and provides several methods of graphical display.

## APPLICATIONS

**Custom Curves** Twenty non-linear curve segments can be loaded into non-volatile memory via the serial port to be used to calculate the desired reading from the signal on input A. With the aid of programs supplied in our software package any text file containing up to 240 data points to be linearized, will be transformed into very accurate data and loaded into the **Micro-C, Mighty-1C, Mighty-4C or Mighty-5C**. Each data point is processed using quadratic equations. The initial file can be prepared on any word processing program.

**Mathematical Functions:** The signals on channels A and B may be mathematically manipulated (A+B, A-B, AxB or A/B) and displayed. A scale factor may be applied to each input channel allowing the result of the calculation to read in engineering units.

**Period:** A single period, or a number of periods selectable by a scale factor of 1 to 9, received during the specified gate time, are measured and averaged, the result is displayed in microseconds, milliseconds or seconds.

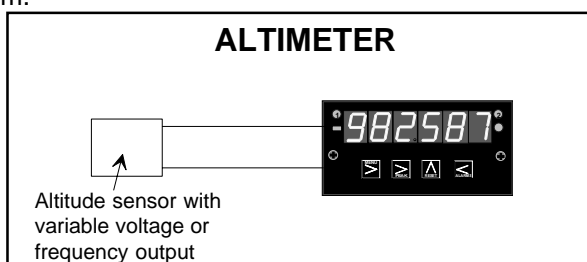

**Totalizing Up/Down** This mode allows the display to be used as an up/down counter or totalizer. A signal input on channel A may be scaled and displayed as a total. A switch control on channel B functions as an up-down control.

**Time Interval** A single time interval, or several time intervals of less than 200 seconds total, are averaged during the specified gate time and displayed in milliseconds.

**Phase Angle** The difference in phase angle between the channel A and B input signals of the same frequency but displaced in time are calculated and displayed. Phase angle is displayed 0 to 360°.

**Batch** This application requires a batch relay card and allows the display to do repetitive batch counting such as filling containers. Channel A input is totaled and compared to a setpoint value. When this batch total reaches a preset value, a batch relay de-energizes and the batch total is added to the grand total. At the end of each batch, the batch total is reset and another batch may then be started.

**Rate or Frequency:** Applications include tachometers and direct frequency measurement. The display measures the period of the signals on channels A and/or B and may be scaled to read in engineering units such as RPM.

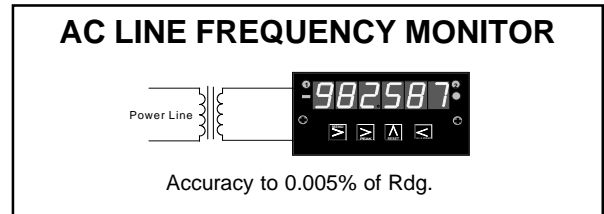
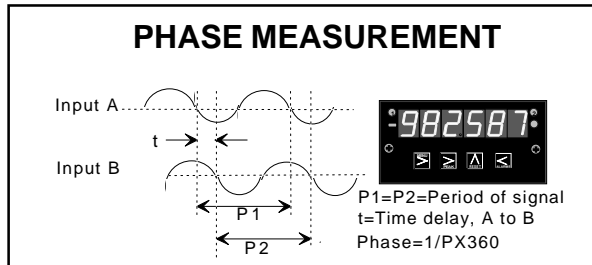

**Distance Measurements (Quadrature)** Used with position encoders to show distance or rotation. Quadrature measurement compares the signals on channels A and B to determine both distance and direction. These meters can also accept a zero reference input and the display will show 1X, 2X or 4X the input signals.

**Analog Voltage & Current Measurements:** Process signals may be measured on channel A and displayed as a rate or square root of rate (flowmeters). Analog signals may be linearized by programming a Custom Curve.

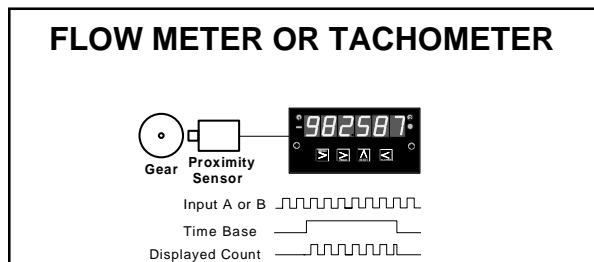
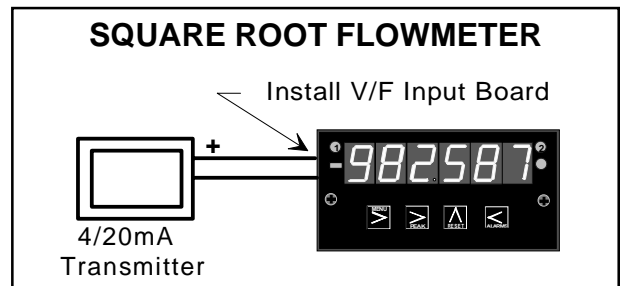
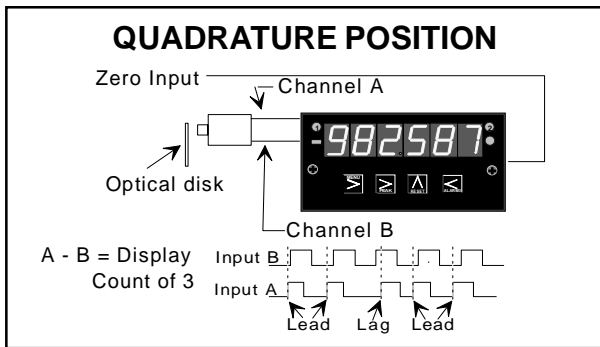

## Counter/Timer Setup Options:

These displays may be setup to operate in a number of different modes. Each signal conditioner input card has selectable features in the menu. There are three items which may be displayed (I1, I2 & I3) by pressing the value select key on the front panel.

With an **Analog (V/F) card installed**, the following items may be displayed (single channel only) for any of the signal input selections A1, A2, A3 or A4 (See the Ordering Guide on page 6). Note: **A Only** may be displayed with a basic counter, all items may be displayed with an extended counter:

### Rate (A1, A2, A3 or A4):

<b>A Only</b>	Calculates Rate for input channel A as (I1)
<b>bAtCH</b>	Calculates Rate for input channel A as (I3), Total as (I1), and Batch Grand Total as (I2).
<b>A Atot</b>	Calculates Rate for input channel A as (I1) and Total as (I2).
<b>Atot A</b>	Calculates Rate for input channel A as (I2) and Total as (I1).
<b>1 / A</b>	Calculates the inverse of Rate for input channel A as (I1).

With a **Dual Channel card installed**, the following items may be displayed for any of the signal input selections C1 through C6. Note: **A b** and **A Only** may be displayed with a basic counter, all items may be displayed with an extended counter.:

### Rate (C1):

<b>A b</b>	Calculates rates for input channel A (I1) and B (I2).
<b>A Only</b>	Calculates rate for input channel A (I1).
<b>BAtch</b>	Calculates rate for input channel A (I3), Total as (I1) and Batch Grand Total as (I2).
<b>A Atot</b>	Calculates rate for input channel A (I1) and Total as (I2).
<b>A btot</b>	Calculates rate for input channel A (I1) and Total for input channel B as (I2).
<b>A + B</b>	Calculates rate for input channel A (I2) Rate for input channel B as (I3) and sum of both input channels as (I1).
<b>A - B</b>	Calculates rate for input channel A (I2) Rate for input channel B as (I3) and difference of both input channels as (I1).
<b>A . B</b>	Calculates rate for input channel A (I2) Rate for input channel B as (I3) and product of both input channels as (I1).
<b>A / B</b>	Calculates rate for input channel A (I2) Rate for input channel B as (I3) and ratio of both input channels as (I1).
<b>A/b-1</b>	Calculates rate for input channel A (I2) Rate for input channel B as (I3) and draw of both input channels as (I1).

### Period (C2):

<b>A b</b>	Calculates Period for input channel A (I1) and B (I2).
<b>A Only</b>	Calculates Period for input channel A (I1).
<b>A + B</b>	Calculates Period for input channel A (I2) Period for input channel B as (I3) and sum of both input channels as (I1).
<b>A - B</b>	Calculates Period for input channel A (I2) Period for input channel B as (I3) and difference of both input channels as (I1).
<b>A . B</b>	Calculates Period for input channel A (I2) Period for input channel B as (I3) and product of both input channels as (I1).
<b>A / B</b>	Calculates Period for input channel A (I2) Period for input channel B as (I3) and ratio of both input channels as (I1).

### Total (C3):

<b>A b</b>	Calculates Totals for input channel A (I1) and B (I2).
<b>A Only</b>	Calculates Total for input channel A (I1).
<b>A-BUpDn</b>	Calculates Total for input channel A minus the Total for input channel B (I1) i.e. up/down counting
<b>burst</b>	Calculates total number of bursts for input channel A (I1) and burst frequency (I2).
<b>b Arat</b>	Calculates Total for input channel B (I1) and Rate for input channel A (I2).
<b>A bUPd</b>	Calculates Total for input channel A (I1) with input channel B as the up/down control.
<b>A binH</b>	Calculates Total for input channel A (I1) with input channel B as the count inhibit control.
<b>A + b</b>	Calculates Total for input channel A (I2), Total for input channel B as (I3) and sum of both inputs as (I1).
<b>A - b</b>	Calculates Total for input channel A (I2), Total for input channel B as (I3) and difference of both inputs as (I1).
<b>A . b</b>	Calculates Total for input channel A (I2), Total for input channel B as (I3) and product of both inputs as (I1).
<b>A / b</b>	Calculates Total for input channel A (I2), Total for input channel B as (I3) and ratio of both inputs as (I1).

### Time Internal (C4): (999 seconds maximum display i.e. 999.999 mS, requires basic counter)

<b>A to b</b>	Calculates time from input A to input B (leading or trailing edge). Display is in mS (I1).
---------------	--

### Stopwatch (C5): (extended counter only, 55 hours maximum display i.e. 55.00.00)

<b>A to A</b>	Calculates the time from input A leading edge to leading edge or trailing edge to trailing edge.
<b>A to b</b>	Calculates the time from input channel A to input channel B (leading or trailing edge of signal).

### Phase Angle (C6): (extended counter only)

<b>A to b</b>	Calculates the Phase Angle of input channel A to input channel B. Displayed 0 to 360 degrees.
---------------	---

With a **Quadrature card installed**, these displays will show total counts from a quadrature input encoder and may be scaled to indicate distance or displacement. Quadrature indicators require a basic counter only.

### Total (Q):

<b>totAL</b>	Calculates the Total or Position as (I1). Note: If the Z channel input is used, the display will not retain "last reading" at power up.
--------------	---

## Selectable Configurations:

Many configurations may be selected through the menu using the front panel keys or with a computer when a serial communications card is installed. Following are a few of the setup choices.

### Display Formats:

**Normal Display:** 999,999; 999,990 (one dummy zero) or 999,900 (two dummy zeros).

**Clock Display (extended counters only):** Clock Standard Format (HH.MM.SS), with timing to 55 hours maximum or Clock Automatic Format with timing starting in mS and then progressively counting in seconds, minutes and then hours. A blinking decimal point is used rather than a colon between hours, minutes and seconds.

**Remote Display:** In this configuration, the meters will operate as a serial input Remote Display showing data sent from a data source such as a PLC or computer. A serial card must be installed in the meter (RS232 or RS485) however, a signal conditioner card is not required.

### Scaling Formats:

Two standard scaling methods are provided, Scale Factor and Multiplier or Coordinates of Two Points. Either method allows independent scaling of input channels A and/or B.

*Example:* Using a dual channel signal conditioner and

selecting **rAtE** (rate) **A + B**, the input pulses on channel A may be scaled and stored as (I2), the input pulses on channel B may be independently scaled and stored as (I3) and the sum of both scaled inputs stored as (I1). By using the view button on the front of the display, you may "view" any of the items.

**Square Root Format (flow meters):** When in the **rAtE** (rate) mode, Square Root of Rate may be selected for either input channel A or B. Square root of rate is independently applied to the scaled inputs and stored as I1, I2 or I3.

**Custom Curves (extended counters only):** A custom curve or linearization may be applied to channel A and/or B independently. Computer programs can be provided by Electro-Numerics, allowing data points to be input via a spread sheet and then mathematically curve fit resulting in a 20 point "best fit" custom linearization.

### Digital Filtering:

Selection may be made of conventional digital filtering or "adaptive" filtering. Either method may be applied to displayed readings, peak readings and analog outputs. Adaptive filtering applies a variable amount of filtering depending on how rapidly the signal is changing. When the input signal is changing rapidly, less filtering is applied allowing the best response to the signal.

---

---

## ELECTRICAL SPECIFICATIONS

### MICRO-C, MIGHTY-1C & MIGHTY-5C

#### Display:

Type ..... 6 Digit, 7-segment  
Digit size ..... Micro-C: 0.56", Mighty-1C: 1",  
Mighty-5C: 5" (discrete Led's in a 7-segment format)  
Type ..... All except Mighty-5C are bright indoor Led's  
Mighty-5C digits are super-bright, daylight readable  
Color ..... Red or Green (Micro-C only)  
Range ..... -999,999 to +999,999

#### Conversion Period:

Gate time ..... 0 to 199.99 seconds  
Technique (frequency) ..... 1 divided by the period  
Rate ..... Gate time + 30ms + 2 periods of the input signal

#### Accuracy at 25°C:

Time Base (crystal) ..... Calibrated to +/-1 Count  
Accuracy at 25°C ..... 0.025%  
Span Tempco ..... 0.003% R/°C  
Zero Tempco ..... 0.003% FS/°C

#### Dual Channel Signal Conditioner:

Types: ..... AC or Pulses from NPN, PNP transistors,  
contact closures, AC line, magnetic  
pickups, turbine flow meters etc.

Channel A: ..... 0 to 1MHz  
Channel B: ..... 0 to 250kHz  
Isolation: ..... Channel A & B share common ground  
Selectable Low Pass Filter: ..... 250Hz and 30kHz  
Hysteresis: ..... selectable from 24mV to 2.3Vp-p  
Debounce Circuitry: ..... selectable 0, 3, 50mS

#### V to F Signal Conditioner:

Input Signal Levels: ..... 0 to 1mA, 4 to 20mA, 0 to 10Vdc

#### Power Supplies:

Voltage (standard) ..... 85 to 264 Vac, 90 to 370 Vdc  
Voltage (optional, except Mighty-5) ..... 8 to 28 Vac, 9 to 37 Vdc  
Frequency ..... DC and 47 to 440 Hz  
Excitation Outputs (+/-5%) ..... 5 Vdc, 100mA max.; 10 Vdc,  
120mA max.; or 24 Vdc, 40 mA max.

Ripple: ..... 100mVp max.

Isolation between power and input/outputs: ..... 250Vac

Insulation dielectric strength: .. 3.5kVac, 5 sec. & 2.3kVac, 1 min.

#### Environmental:

Operating temperature ..... 0 to 55°C  
Storage temperature ..... -40 to 85°C  
Relative humidity ..... 90% from 0°C to 40°C

#### Enclosure:

Micro-C ..... 1/8 DIN plastic w/ sealed front, 92 x 45mm cutout  
Mighty-1C ..... Aluminum w/ sealed front, 183 x 90.5mm cutout  
Mighty-5C ..... Aluminum, NEMA-4X, surface or bracket mount

#### Options:

See the Owners Manual for full specifications for optional:

Dual Setpoint Controller  
Analog Outputs  
RS232 & RS485 Interface

# MECHANICAL SPECIFICATIONS

## MICRO-C (1/8 DIN DPM)

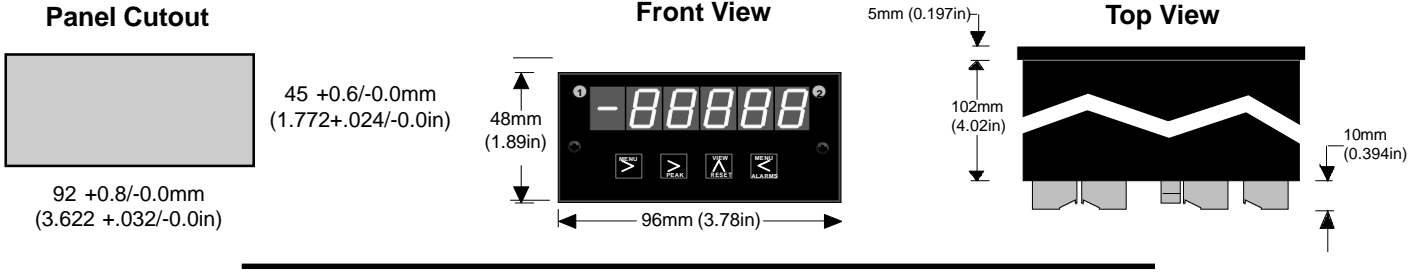

## MIGHTY-1C

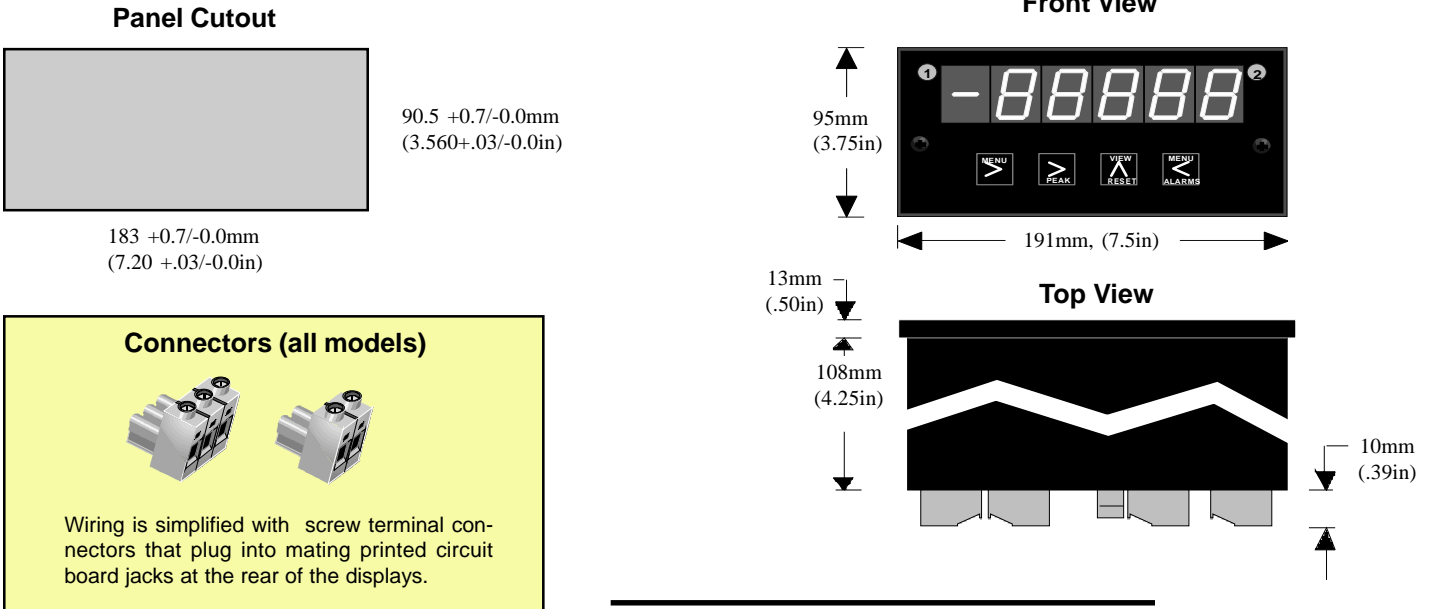

### Connectors (all models)

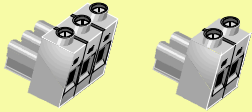

Wiring is simplified with screw terminal connectors that plug into mating printed circuit board jacks at the rear of the displays.

## MIGHTY-5C

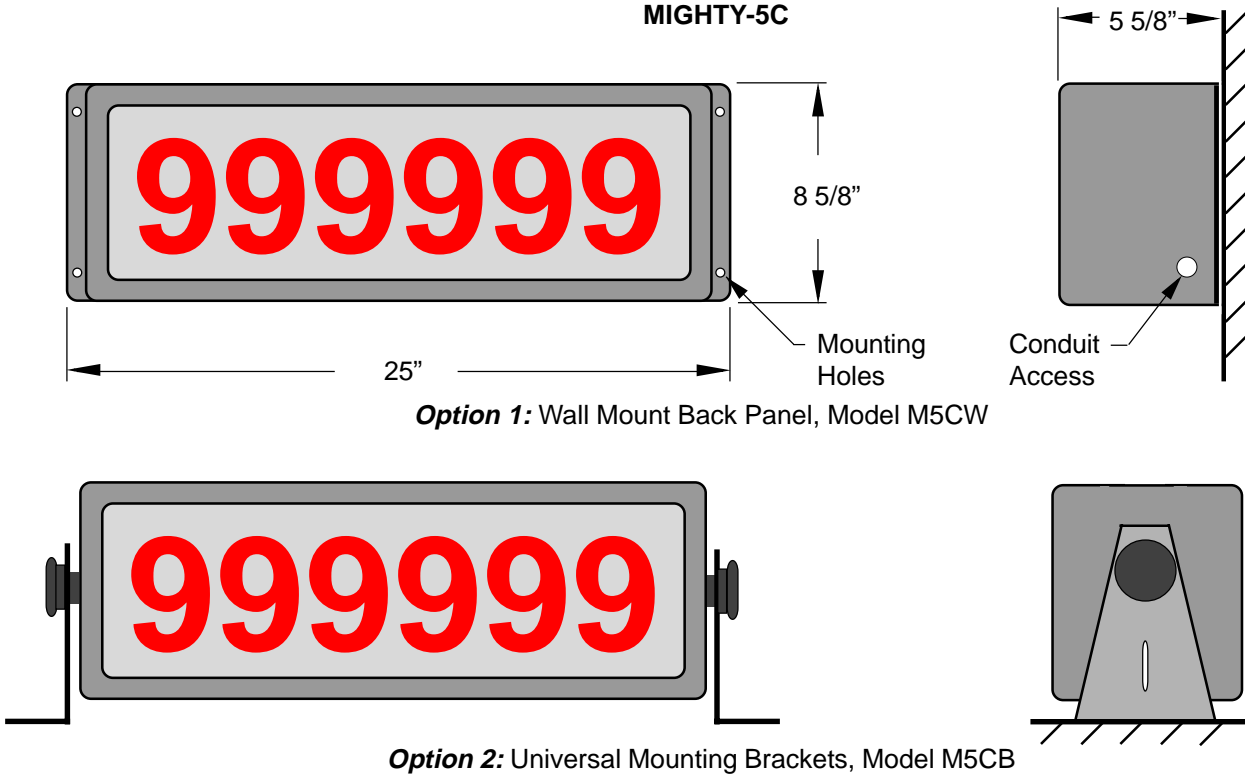

# ORDERING GUIDE

One entry required per block. For example, model MCR0JHHC3 is a Micro-C counter/totalizer with red 0.56" Led display, high level power supply and 0-10 Vdc analog output. Note: Default ranges are shown below. All ranges can be scaled to read in engineering units. Add -SC option if required.

**Display Color & Digit Size**

- MCR** ..... MICRO-C, Basic Counter, Red 0.56" Led's
- MCG** ..... MICRO-C, Basic Counter, Green 0.56" Led's
- M1CR** ..... MIGHTY-1C, Basic Counter, Red 1" Led's

**Mighty-5C** (Red, 5" outdoor Led's):

- M5CW** ..... Wall Mount, NEMA-4X case
- M5CB** ..... Bracket Mount, NEMA-4X case

For extended features, add "E" to the part number i.e. MCRE

**Display Power** (except Mighty-5C)

- 0** ..... 85 to 264 Vac, 90 to 370 Vdc
  - 1** ..... 8 to 28 Vac, 9 to 37 Vdc
- Mighty-5C requires no entry, "0" is standard.*

**Analog Output or Batch Relay Card** (optional)

- H** ..... None
- J** ..... 0 to 10 Vdc
- K** ..... 0 to 20 (4/20) mAdc
- T** ..... Batch Relay Card, 10 A relay

**Setpoint Output** (optional)

- H** ..... None
- R** ..... Dual 10 A relay output
- C** ..... Open collector output

**Digital Interface** (optional)

- H** ..... None
- 2** ..... RS-232
- 4** ..... RS-485
- B** ..... Parallel BCD

**Signal Conditioners** (select one)

Default ranges are shown, meters may be customer scaled or select **-SC**, Special Configuration when factory scaling is required.

**Remote Display**

- RD** ..... Requires basic counter, RS232 or RS485 Digital Interface option and no signal conditioner

**Analog (V/F) Input, single channel**

- A1** (Rate) ..... A Only, 4/20 mAdc = 20,000
- A2** (Rate) ..... A Only, 0 to 1 mAdc = 10,000
- A3** (Rate) ..... A Only, 0 to 10 Vdc = 10,000
- A4** (Rate) ..... A Only, 0 to 100 mVdc = 10,000

**Counter/Timer Input, dual channel**

- C1** (Rate) ..... A Only, 1000 Hz = 1000, Gate = 1 S
  - C2** (Period) ..... A to b, 0 to 999.999 S, Gate = 1 S
  - C3** (Count/Total) ..... A Only, 1000 counts = 1000
  - C4** (Time Interval) ..... A to b, 0 to 999.999 S, Gate = 1 S
  - C5** (Stopwatch) ..... A to b, 0 to 55 Hrs (H, M, S clock display)
  - C6** (Phase Angle) ..... A to b, 0 to 360.0 (degrees)
- Note: C5 & C6 require an extended version counter.

**Quadrature Input**

- Q** ..... Quadrature
- Specify encoder specifications and scaling required.  
Default Configuration: Single ended, count up, A leads B, one count per cycle (1X) and no zero index.

**Special Configuraion**

- SC** Specify when scalings or configurations other than those defaults shown above are required.

## WARRANTY & SERVICE

### LIMITED PRODUCT WARRANTY:

Electro-Numerics Incorporated warrants these products to be free of defects in material and workmanship for two years from date of shipment to original customer. This warranty on materials and workmanship may be considered as unconditional provided that, in the opinion of Electro-Numerics, the equipment has not been mechanically, environmentally or electrically abused and has been installed, maintained and operated within the limits of rated or normal usage.

Defective products must be sent, transportation charges prepaid with notice of the defect, to our plant in Temecula CA. This warranty is limited, at the option of Electro-Numerics, to repair, replacement, or an appropriate credit adjustment not to exceed the original equipment sales price. All warranty freight charges are F.O.B., our plant, Temecula, CA. Electro-Numerics assumes no liability in connection with the

sales of its products beyond that stated above and is not responsible for any incidental or consequential loss or damage which might result from a failure of any Electro-Numerics' product.

### SERVICE:

Products being returned for service should be sent, freight prepaid, to Electro-Numerics, Inc., 42213 Sarah Way, Temecula, CA, U.S.A. to the attention of the Repair Department with a full description of the problem or reason for return. All items sent in for service are subject to a minimum evaluation charge of \$65.00 in the event that the product is found to be out-of-warranty or, if under warranty, not in need of additional service. Out-of-Warranty service and repair charges will be quoted on a case-by-case basis. All repaired products will be shipped to you F.O.B., Temecula, CA.

---

---

## CONDITIONS OF SALE

### Freight:

F.O.B Temecula, California. Insurance and handling charges are added to all shipments. Handling charges are computed at 1% of the shipment product cost with \$1 minimum & \$7 maximum.

### Prices:

Prices published in catalogs, price lists or on the Internet are not offers to sell and are subject to change without notice. General price information should be specifically confirmed. Product listings, specifications and manufacturing details are subject to change without notice.

### Payment Terms:

Net 30 days from invoice date with credit approval, Visa, Mastercard, American Express or C.O.D.. A 1<sup>1/2</sup>% service charge will be added on balances beyond 30 days. All returns must be authorized and pass factory inspection. Returns are subject to a restocking fee and a maximum of 90 days from invoice date.



42213 Sarah Way, Temecula CA 92590

**1-800-854-8530** Tel: 951-699-2437 Fax: 951-695-7246

Web Site: <http://www.electronumerics.com>