

DIN SERIES

DIGITAL PANEL METERS



**ELECTRO-
NUMERICS, INC.**

MODEL SELECTION GUIDE

The DIN Series of Digital Panel Meters are rugged low cost meters for the measurement of dc voltage, dc current, Process voltage and Process current signals. All models are housed in a standard 1/8 DIN size panel mount case and feature large bright LED digits. These units allow easy selection of several ranges and provide adjustable scaling to read directly in engineering units. Two choices of display resolution are offered. EN35 series meters are 3 1/2 digit (1,999 max. count) while the EN45 series are 4 1/2 digit (19,999 max. count).

	Model	Ranges	Power	Connection	Page
dc Voltmeters 3 1/2 Digit 4 1/2 Digit	EN35V EN45V	0.2, 2, 20, 200V 2, 20, 200V	9/32Vdc or 115/230Vac	Edge -card std. or opt. screw terminal	2 & 3 6 & 7
dc Current Meters 3 1/2 Digit 4 1/2 Digit	EN35V N/A	20uA to 200mA N/A	9/32Vdc or 115/230Vac	Edge -card std. or opt. screw terminal	2 & 3
Process Voltage Receivers 3 1/2 Digit 4 1/2 Digit	EN35P EN45P	0/5, 1/5, 0/10 or 1/10Vdc	9/32Vdc or 115/230Vac	Screw terminal Screw terminal	4 & 5 8 & 9
Process Current Loop Receivers 3 1/2 Digit 4 1/2 Digit	EN35P EN45P	0/20 or 4/20mA	9/32Vdc or 115/230Vac	Screw terminal Screw terminal	4 & 5 8 & 9
Process Voltage Receivers with Excitation Output 3 1/2 Digit 4 1/2 Digit	EN35E EN45P,E	0/5, 1/5, 0/10 or 1/10Vdc	9/32Vdc or 115/230Vac	Screw terminal Screw terminal	4 & 5 8 & 9
Process Current Loop Receivers with Excitation Output 3 1/2 Digit 4 1/2 Digit	EN35E EN45P,E	0/20 or 4/20mA	9/32Vdc or 115/230Vac	Screw terminal Screw terminal	4 & 5 8 & 9
Mounting and Dimensions (all Models)					10

MODEL EN35V 3 1/2 DIGIT DC VOLTMETER



FEATURES

- Economical dc Voltmeter
- Replacement for Newport 201AN
- 200mV, 2V, 20V & 200V dc Ranges
- 115Vac Power
- Broad Range Scaling; 20 to 1,999
- Automatic Zero and Polarity
- Differential Signal Input
- 2 Year Warranty

OPTIONS

- 9 to 32Vdc Power
- 230Vac Power
- dc Current Measurement
- Screw Terminals for Signal and Power
- Zero Offset Adjustment

DESCRIPTION

This model is a low cost 3 1/2 digit (+/-1,999 count) digital voltmeter accepting **dc voltages** in four **user selectable ranges**. This meter fits a standard 1/8 DIN cutout (92mm X 45mm) and is a direct replacement for Newport model 201AN with the exception of case length. 115Vac power is provided standard with 230Vac and 9 to 32Vdc power available as options. The signal input is **true differential, bipolar, auto-zero** and **auto-polarity**. **Broad range user adjustable scaling** from 20 to 1,999 counts is provided. Options include: T1 Screw Terminal Barrier Strip for signal and power, dc Current Measurement (20uA to 200mA in 5 ranges) and Zero Offset Control. High quality construction and conservative design makes this display the choice for industrial applications. A **Two-Year Warranty** is standard.

SPECIFICATIONS

SIGNAL INPUT

Voltage Ranges

Range	+/-199.9 mV	+/-1.999 V	+/-19.99 V	+/-199.9 V
Resolution	100 uV	1 mV	10 mV	100 mV
Maximum Input	130 Vp	130 Vp	250 Vp	250 Vp
Input Resistance	50 Kohm	50 Kohm	50 Kohm	50 Kohm
Bias Current	1 pA	1 pA	1 pA	1 pA

Current Ranges

Range	Resolution	Input Resistance	Maximum Overload
+/-19.99 uA	10 nA	10 Kohm	5 mA
+/-199.9 uA	100 nA	1 Kohm	15 mA
+/-1.999 mA	1 uA	100 ohm	50 mA
+/-19.99 mA	10 uA	10 ohm	150 mA
+/-199.9 mA	100 uA	1 ohm	500 mA

INPUT CONFIGURATION

Configuration	Differential, bipolar
Zero	Automatic
Zero Offset Control (ZO option)	+/-100 counts
Span (User Adjustable)	+/-20 to 1,999 counts

NOISE REJECTION

NMR	56 dB, 50/60 Hz
CMR, ac GND to SIG GND	120dB, dc to 60Hz
CMR, SIG LO to SIG GND	80 dB, dc to 60 Hz
CMV, ac GND to SIG GND	1500 Vp per HV test
CMV, SIG LO to SIG GND	+/-1 Vp

ACCURACY AT 25°C

Maximum Error	+/-0.05% of reading +/-1 count
Span TempCo	+/-0.01% of reading per °C
Step response	500 ms
Warmup to rated accuracy	2 min

ANALOG TO DIGITAL CONVERSION

Technique	Dual-slope, average value
Polarity	Automatic, (-) sign only
Integration period	330 ms
Read rate	3 readings per second

3-WIRE RATIO REFERENCE

Analog input range	+/-200 mV	+/-2 , +/-20, +/-200 V
External ref. inpu	+0.05 to +0.2 V	+0.5 to +2.0 V
Load on ref. std.	2 Kohm	2 Kohm
Load on ref. opt.	100 Mohm	100 Mohm
Accuracy	99.9 %	99.9 %

DISPLAY

Type	7-segment, red-orange LED
Height	14.2 mm (0.56")
Symbols	-1.8.8.8
Decimal points	Three positions programmable internally or at connector J1
Overrange indication	Three least-significant digits blank

ELECTRO-NUMERICS, INC.

Call 800-854-8530 or FAX (951) 695-7246 for Applications Assistance

PAGE 2

DIGITAL CONTROLS

HOLD input TTL or 5 V CMOS compatible

POWER

AC voltages 115 or 230 Vac +15%, -10% 47 to 400Hz
 DC voltage 9 to 32 Vdc, isolated to 300 Vp
 Power Consumption 2.5 W (nominal)
 Output voltages +5Vdc and -5Vdc at 10mA max.

ENVIRONMENTAL

Operating temperature -10 to 60°C
 Storage temperature -40 to +85°C
 Relative humidity 95% at 40°C (non-condensing)

MECHANICAL

Dimensions 1/8 DIN case (see Dimensions & Mounting)
 Weight 340 g (12 oz)
 Case material 94 V-0 UL-rated polycarbonate
 Window material Red acrylic, silkscreened

Connectors:
 Power and Signal (optional) T1 screw-terminal barrier strip
 Standard I/O connector (accessory):
 J1 Dual 18 pin edge card connector P/N 411-606

PIN ASSIGNMENTS

DUAL 18 PIN EDGE-CARD CONNECTION

J1		
AC HIGH	A	1
	B	2
AC GND or -DC PWR	C	3
	D	4
	E	5
	F	6
	H	7
<u>DP</u> (199.9)	J	8
<u>DP</u> (19.99)	K	9
<u>DP</u> (1.999)	L	10
+5Vdc OUTPUT	M	11
-5Vdc OUTPUT	N	12
+ REFERENCE	P	13
HOLD	R	14
ANALOG GND	S	15
ANALOG GND	T	16
SIGNAL HIGH	U	17
	V	18

AC LOW or +DC PWR

DIGITAL GND
DP (199.9)
DP (19.99)
DP (1.999)

+5 Vdc OUTPUT
 HOLD

SIGNAL LOW
 SIGNAL HIGH
 ANALOG OUT.

For single-ended signal input, jumper J1-16 to J1-T.

SIX TERMINAL BARRIER STRIP CONNECTION (Removes Signal and Power inputs from J1)

(AC POWER VERSIONS)

(DC POWER VERSIONS)

T1

1	AC HIGH
2	AC LOW
3	AC GND

4	ANALOG GND
5	SIGNAL LOW
6	SIGNAL HIGH

T1

1	N/C
2	+ DC PWR
3	DC PWR RET

4	ANALOG GND
5	SIGNAL LOW
6	SIGNAL HIGH

ORDERING GUIDE

Make a maximum of one entry per box and separate by commas. An asterisk requires no entry.

Example: **EN35V, 2V=18.50, DP2, T1, 9-32Vdc**

EN35V 3 1/2 DIGIT dc VOLTMETER

INPUT RANGE
DC Voltage Measurement
 (Specify full scale counts)

200mV +/-199.9 mVdc
2V +/-1.999 Vdc
20V +/-19.99 Vdc
200V +/-199.9 Vdc

DC Current Measurement
 (Specify full scale counts)

20uA 19.99 uA dc current range
200uA 199.9 uA dc current range
2mA 1.999 mA dc current range
20mA 19.99 mA dc current range
200mA 199.9 mA dc current range

3-WIRE RATIO IMPEDANCE
 * Standard (2 Kohm)
ER High Impedance (100 Mohm)

DECIMAL POINT
 * Programmable at J1
DP1 1.999, internally wired
DP2 19.99, internally wired
DP3 199.9, internally wired

TERMINAL STRIP CONNECTION
 * Standard J1 connection
T1 Terminal strip for signal & power

ZERO OFFSET
 * Standard automatic zero
ZO Zero offset adjustable +/-100 counts

POWER
 * 115 Vac, 47 to 400 Hz
230Vac 230 Vac, 47 to 400 Hz
9-32Vdc Isolated 9 to 32 Vdc

ACCESSORIES

411-606 Dual 18 pin edge-card connector

HW04 Environmental Cover Kit

MODELS EN35P & EN35E 3 1/2 DIGIT PROCESS METERS



FEATURES

- Process Meter (EN35P) & Process Meter with Excitation Voltage (EN35E)
- Low Cost Replacements for Newport Models 202A-P and 202A-E
- 4/20mA, 0/20mA, 1/5V, 0/10V Ranges
- 115Vac Power
- Broad Range Adjustable Scaling
Span: +/-20 to 1,999 Counts
Zero: +/-1,000 Counts
- Screw Terminal Connections
- 1/8 DIN Case
- Jumper Selectable Decimal Point, Polarity and LSD On/Off
- 2 Year Warranty

OPTIONS

- 9 to 32Vdc Power
- 230Vac Power

DESCRIPTION

These models are low cost 3 1/2 digit (+/-1,999 count) Digital Process Meters accepting **dc voltage** or **current loops** typically supplied by process transducers. These meters fit a standard 1/8 DIN cutout (92mm X 45mm) and are direct replacements for Newport models 202A-P and 202A-E with the exception of case length. 115Vac power is provided standard with 230Vac and 9 to 32Vdc power available as options. **Broad range scaling** and **zero offset** allow these meters to display directly in engineering units. Decimal Points, Polarity (- or none) and LSD on/off (1,999 or 199 display) are selectable by jumper on the display board.

Model EN35P is a process indicator only while model EN35E provides the additional feature of dc excitation voltage output. This output may be used to provide transducer power in a two or four wire configuration. High quality construction and conservative design makes this display the choice for industrial applications. A **Two-Year Warranty** is standard.

SPECIFICATIONS

SIGNAL INPUT

DC Voltage Ranges

Range	0 to 5 V	0 to 10 V	1 to 5 V	1 to 10 V
Maximum Input	250 V	250 V	250 V	250 V
Input Resistance	1 Mohm	1 Mohm	1 Mohm	1 Mohm
Bias Current	5 pA	5 pA	5 pA	5 pA

DC Current Loop Ranges

Range	0 to 20 mA	4 to 20 mA
Maximum Current	55 mA	55 mA
Input Resistance	13 ohm	13 ohm
Bias Current	50 pA	50 pA
Burden Voltage	200 mV	200 mV

INPUT CONFIGURATION

Configuration	Single ended, bipolar
Zero Offset Control	+/-1,000 counts
Span Adjustment	+/-20 to 1,999 counts

NOISE REJECTION

NMR, SIG HI to SIG LO	56 dB, 50/60 Hz
CMR, SIG GND to SIG HI	120 dB, dc to 60Hz
CMR, SIG GND TO PWR GND	120 dB, dc to 60 Hz
CMV, SIG GND TO PWR GND	1500 Vp per HV test

ACCURACY AT 25°C

Maximum Error	+/-0.05% of reading +/-1 count
Span TempCo	+/-0.03% of reading per °C
Zero TempCo	+/-0.01% of offset per °C
Step response	500ms
Warmup to rated accuracy	2 min

ANALOG TO DIGITAL CONVERSION

Technique	Dual-slope, average value
Polarity	Automatic and selectable (- or none)
Integration period	330 ms
Read Rate	3 readings per second

DISPLAY

Type	7-segment, red-orange LED
Height	14.2 mm (0.56")
Symbols	-1.8.8.8
Decimal points	Three positions programmable by jumper on display board or at J1
Overrange indication	Three least-significant digits blank
Least Significant Digit (LSD)	Controllable on/off on display board. Display: 1,999 or 199

DIGITAL CONTROLS

HOLD input TTL or 5 V CMOS compatible

EXCITATION OUTPUT (Model EN35E)

Output Voltage 4.5 to 24Vdc adjustable
Output Current 50mA max

POWER

AC voltages 115 or 230 Vac +15%, -10% 47 to 400 Hz
DC voltage 9 to 32 Vdc, isolated to 300 Vp
Power Consumption 2.5 W (nominal)
Output voltages +5.0Vdc and -5Vdc at 10mA max

ENVIRONMENTAL

Operating temperature -10 to 60°C
Storage temperature -40 to +85°C
Relative humidity 95% at 40°C (non-condensing)

MECHANICAL

Dimensions 1/8 DIN case (see Dimensions & Mounting)
Weight 340 g (12oz)
Case material 94 V-0 UL-rated polycarbonate
Window material Red acrylic, silkscreened

Connectors:

Power and Signal T1 screw-terminal barrier strip
Display Control and Output Voltages (accessory):
J1 Dual 18 pin edge-card connector P/N 411-606

PIN ASSIGNMENTS

DUAL 18 PIN EDGE-CARD CONNECTION

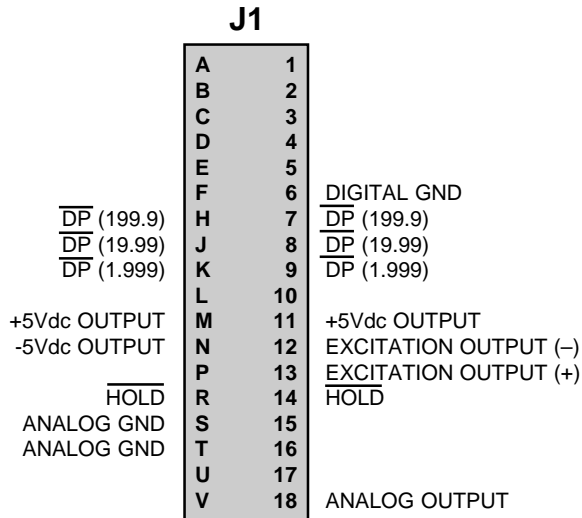

SIX TERMINAL BARRIER STRIP CONNECTION

T1 (AC POWER)

1	AC HIGH
2	AC LOW
3	AC GND
4	ANALOG GND
5	SIGNAL LOW
6	SIGNAL HIGH

T1 (DC POWER)

1	N/C
2	+ DC PWR
3	DC PWR RET
4	ANALOG GND
5	SIGNAL LOW
6	SIGNAL HIGH

ORDERING GUIDE

Make a maximum of one entry per box and separate by commas. An asterisk requires no entry.

Example:

EN35P, 4mA = 000, 20mA = 18.50, DP2, 9-32Vdc

EN35E **3 1/2 DIGIT PROCESS METER WITH EXCITATION OUTPUT**

Excitation Output: Specify 4.5 to 24Vdc @ 50mA

EN35P **3 1/2 DIGIT PROCESS METER**

INPUT RANGE

Voltage input:

Specify the minimum dc voltage input for a reading of 000 and the maximum voltage input for the desired full scale counts.
i.e. 1V = 000, 5V=1,500.

Current Loop input:

Specify the minimum dc current input for a reading of 000 and the maximum current input for the desired full scale counts.
i.e. 4mA= 000, 20mA=1,999.

DECIMAL POINT
* Programmable at J1
DP1 1.999, internally jumpered
DP2 19.99, internally jumpered
DP3 199.9, internally jumpered

POLARITY
* - sign only
NP no sign

LSD CONTROL
* 1,999 and -1,999 display
ND 199 and -199 display

POWER
* 115 Vac, 47 to 400 Hz
230Vac 230 Vac, 47 to 400 Hz
9-32Vdc Isolated 9 to 32 Vdc

ACCESSORIES
411-606 Dual 18 pin edge-card connector
HW04 Environmental Cover Kit

MODEL EN45V 4 1/2 DIGIT DC VOLTMETER



FEATURES

- Economical dc Voltmeter
- Replacement for Newport 2001
- 2V, 20V & 200V dc Ranges
- 115Vac Power
- Broad Range Scaling; 400 to 19,999
- Automatic Zero & Polarity
- Differential Signal Input
- Multiplexed BCD Output
- 2 Year Warranty

OPTIONS

- 9 to 32Vdc Power
- 230Vac Power
- Screw Terminals for Signal & Power
- Zero Offset Adjustment

DESCRIPTION

This model is a low cost 4 1/2 digit (+/-19,999 count) digital voltmeter accepting **dc voltages** in three **user selectable ranges**. This meter fits a standard 1/8 DIN cutout (92mm X 45mm) and is a direct replacement for Newport model 2001 with the exception of case length. 115Vac power is provided standard with 230Vac and 9 to 32Vdc power available as options. The signal input is **true differential, bipolar, auto-zero** and **auto-polarity**. Broad range **user adjustable scaling** from 400 to 19,999 counts is provided. Options include: T1 Screw Terminal Barrier Strip for signal and power and Zero Offset Control. High quality construction and conservative design makes this display the choice for industrial applications. A **Two-Year Warranty** is standard.

SPECIFICATIONS

SIGNAL INPUT

Range	+/-1.9999	+/-19.999 V	+/-199.99V
Resolution	100 μ V	1 mV	10 mV
Maximum Input	130 Vp	250 Vp	250 Vp
Input Resistance	250 Kohm	1 Mohm	1 Mohm
Bias Current	1 pA	1 pA	1 pA

INPUT CONFIGURATION

Configuration	Differential, bipolar
Zero	Automatic
Zero Offset Control (ZO option)	+/-100 counts
Span (User Adjustable)	+/-400 to 19,999 counts

NOISE REJECTION

NMR SIG HIGH to SIG LO	56 dB, 50/60 Hz
CMR, SIG LO to ANA GND	86 dB, dc to 60Hz
CMR, ac GND to ANA GND	120 dB, dc to 60 Hz
CMV, ac GND to ANA GND	1500 Vp per HV test
CMV, SIG LO to ANA GND	+/-1 Vp

ACCURACY AT 25°C

Maximum Error	+/-0.01% of reading +/-1 count
Span TempCo	+/-0.01% of reading per °C
Step response	1.0 s
Warmup to rated accuracy	2 min

ANALOG TO DIGITAL CONVERSION

Technique	Dual-slope, average value
Polarity	Automatic, (-) sign only
Integration period	400 ms
Read rate	2.5 readings per second

3-WIRE RATIO REFERENCE

Analog input range	+/-2V, +/-20V, +/-200V
External reference input	+/-0.5V to +2.0V
Load on reference (standard)	10 Kohm
Load on reference (optional)	100 Mohm
Accuracy	99.98%

DISPLAY

Type	7-segment, red-orange LED
Height	14.2 mm (0.56")
Symbols	-1.8.8.8.8
Decimal points	Four positions selectable by jumper
Overrange indication	Four least-significant digits flash

DIGITAL SIGNALS AND CONTROLS

HOLD input	TTL or 5V CMOS compatible
BLANKING input	TTL or 5V CMOS compatible
BCD Output (Multiplexed)	TTL or 5V CMOS compatible

POWER

AC voltages	115 or 230 Vac +15%, -10% 47 to 400 Hz
DC voltage	9 to 32 Vdc, isolated to 300 Vp
Power Consumption	4.5 W (nominal)
Output voltages	+5.0 and -5.0 Vdc, 10 mA max.

ELECTRO-NUMERICS, INC.

Call 800-854-8530 or FAX (951) 695-7246 for Applications Assistance

PAGE 6

ENVIRONMENTAL

Operating temperature -10 to 60°C
 Storage temperature -40 to +85°C
 Relative humidity 95% at 40°C (non-condensing)

MECHANICAL

Dimensions 1/8 DIN case (see Dimensions & Mounting)
 Weight 340 g (12 oz)
 Case material 94 V-0 UL-rated polycarbonate
 Window material Red acrylic, silkscreened

Connectors:

Power and Signal (optional) T1 screw-terminal barrier strip
 Standard I/O connector (accessory):
 J1 Dual 18 pin edge card connector P/N 411-606

PIN ASSIGNMENTS

DUAL 18 PIN EDGE-CARD CONNECTION

		J1			
AC HIGH	A	1			
	B	2	AC LOW or +DC PWR		
AC GND or DC PWR RET	C	3			
	D	4			
DIGIT SELECT 1	E	5			
DIGIT SELECT 2	F	6	BCD 1		
DIGIT SELECT 3	H	7	BCD 2		
DIGIT SELECT 4	J	8	BCD 4		
DIGIT SELECT 5	K	9	BCD 8		
STROBE	L	10	OVERRANGE		
POLARITY	M	11	-5Vdc OUTPUT		
DATA READY	N	12	+5Vdc OUTPUT		
	P	13	+ REFERENCE		
	R	14			
DIGITAL GND	S	15	HOLD		
ANALOG GND	T	16	SIGNAL LOW		
BLANKING	U	17	SIGNAL HIGH		
100kHz OSC	V	18			

For single-ended signal input, jumper J1-16 to J1-T.

SIX TERMINAL BARRIER STRIP CONNECTION

(Removes Signal and Power inputs from J1)

(AC POWER VERSIONS)

T1

1	AC HIGH
2	AC LOW
3	AC GND
4	ANALOG GND
5	SIGNAL LOW
6	SIGNAL HIGH

(DC POWER VERSIONS)

T1

1	N/C
2	+ DC PWR
3	DC PWR RET
4	ANALOG GND
5	SIGNAL LOW
6	SIGNAL HIGH

ORDERING GUIDE

Make a maximum of one entry per box and separate by commas. An asterisk requires no entry.

Example:

EN45V, 2V=1.5000, DP1, T1, 230Vac

 **EN45V** 4 1/2 DIGIT dc VOLTMETER

 **INPUT RANGE**
 (Specify full scale counts)
2V +/-1.9999 Vdc
20V +/-19.999 Vdc
200V +/-199.99 Vdc

 **3-WIRE RATIO IMPEDANCE**
 * Standard (6 Kohm)
ER High Impedance (100 Mohm)

 **DECIMAL POINT**
 * None
DP1 1.9999, internally wired
DP2 19.999, internally wired
DP3 199.99, internally wired
DP4 1999.9, internally wired

 **TERMINAL STRIP CONNECTION**
 * Standard J1 connection
T1 Terminal strip for signal & power

 **ZERO OFFSET (+/-100 counts)**
 * Standard automatic zero
ZO Zero offset adj.: +/-100 counts

 **POWER**
 * 115 Vac, 47 to 400 Hz
230Vac 230 Vac, 47 to 400 Hz
9-32Vdc Isolated 9 to 32 Vdc

ACCESSORIES

411-606 Dual 18 pin edge-card connector

HW04 Environmental Cover Kit

MODEL EN45P 4 1/2 DIGIT PROCESS METER



FEATURES

- Economical 4 1/2 Digit Process Meter
- Replacement for Newport 2002A-P
- 4/20mA, 0/20mA, 1/5V, 0/10V Ranges
- 115Vac Power
- Broad Range Adjustable Scaling
Span: +/-400 to 19,999 Counts
Zero: +/-10,000 Counts
- Screw Terminal Connection
- 1/8 DIN Case
- Selection of Decimal & Polarity
- 2 Year Warranty

OPTIONS

- 4.5 TO 24Vdc Excitation Output
(Replacement for Newport 2002A-E)
- 9 to 32Vdc Power
- 230Vac Power

DESCRIPTION

This model is a low cost 4 1/2 digit (+/-19,999 count) Digital Process Meter accepting **dc voltage** and **current loops** typically supplied by process transducers. This meter fits a standard 1/8 DIN cutout (92mm X 45mm) and is a direct replacement for Newport model 2002A-P and 2002A-E with the exception of case length. 115Vac power is provided standard with 230Vac and 9 to 32Vdc power optional. **Broad range scaling** and **zero offset** allows this meter to display directly in engineering units. Decimal Points, Polarity (- or none) and LSD on/off (19,999 or 1,999 display) are selectable by jumper on the display board. Multiplexed BCD Output is standard. High quality construction and conservative design makes this display the choice for industrial and process control applications. A **Two-Year Warranty** is standard.

SPECIFICATIONS

SIGNAL INPUT

DC Voltage Ranges

Range	0 to 5 V	0 to 10 V	1 to 5 V	1 to 10 V
Maximum Input	250 Vp	250 Vp	250 Vp	250 Vp
Input Resistance	1 Mohm	1 Mohm	1 Mohm	1 Mohm
Bias Current	5pA	5pA	5pA	5 pA

DC Current Loop Ranges

Range	0 to 20 mA	4 to 20 mA
Maximum Current	55 mA	55 mA
Input Resistance	120 ohm	120 ohm
Bias Current	50 pA	50 pA
Burden voltage	200mV	200mV

INPUT CONFIGURATION

Configuration	Single ended, bipolar
Zero Offset Control	+/-10,000 counts
Span Adjustment	+/-400 to 19,999 counts

NOISE REJECTION

NMR, SIG HI to SIG LO	70 dB, 50/60 Hz
CMR, SIG GND TO PWR GND	120 dB, dc to 60 Hz
CMV, SIG GND TO PWR GND	1500 Vp per HV test

ACCURACY AT 25°C

Maximum error	+/-0.01% of span +/-2 counts
Zero Temp-Co	+/-0.5 counts /°C
Span Temp-Co	+/-0.01% of span /°C
Full scale step response	1.0 s
Warmup to rated accuracy	2 min

ANALOG TO DIGITAL CONVERSION

Technique	Dual-slope, average value
Polarity	Automatic and selectable (- or none)
Integration period	400 ms
Read Rate	2.5 readings per second

DISPLAY

Type	7-segment, red-orange LED
Height	14.2 mm (0.56")
Symbols	-1.8.8.8.8
Decimal points	Four positions programmable by jumper on display board
Overrange indication	Four least-significant digits flash
Least Significant Digit (LSD)	Controllable on/off

DIGITAL SIGNALS AND CONTROLS

HOLD input	TTL or 5V CMOS compatible
DISPLAY BLANKING input	TTL or 5V CMOS compatible
BCD output (multiplexed)	TTL compatible

ELECTRO-NUMERICS, INC.

Call 800-854-8530 or FAX (951) 695-7246 for Applications Assistance

PAGE 8

POWER

AC voltages 115 or 230 Vac +15%, -10% 47 to 400 Hz
 DC voltage 9 to 32 Vdc, isolated to 300 Vp
 Power Consumption 4.5 W (nominal)
 Output voltages (Std.) +5.0 and -5.0Vdc, 10mA (max.)

EXCITATION VOLTAGE OUTPUT (E OPTION)

Output 4.5 to 24Vdc at 50mA (adjustable)

ENVIRONMENTAL

Operating temperature -10 to 60°C
 Storage temperature -40 to +85°C
 Relative humidity 95% at 40°C (non-condensing)

MECHANICAL

Dimensions 1/8 DIN case (see Dimensions & Mounting)
 Weight 340 g (12oz)
 Case material 94 V-0 UL-rated polycarbonate
 Window material Red acrylic, silkscreened

Connectors:
 Power and Signal T1 screw-terminal barrier strip
 Display Control, BCD & Output Voltages (accessory):
 J1 Dual 18 pin edge-card connector P/N 411-606.

PIN ASSIGNMENTS

DUAL 18 PIN EDGE-CARD CONNECTION

J1		
A	1	
B	2	
C	3	
D	4	
E	5	
F	6	BCD 1
H	7	BCD 2
J	8	BCD 4
K	9	BCD 8
L	10	OVERRANGE
M	11	-5.0 Vdc OUTPUT
N	12	+5.0 Vdc OUTPUT
P	13	
R	14	EXCITATION (+)
S	15	HOLD
T	16	
U	17	
V	18	

DIGIT SELECT 1	E
DIGIT SELECT 2	F
DIGIT SELECT 3	H
DIGIT SELECT 4	J
DIGIT SELECT 5	K
STROBE	L
POLARITY	M
DATA READY	N
EXCITATION (-)	P
DIGITAL GND	S
ANALOG GND	T
BLANKING	U
100 kHz OSC	V

SIX TERMINAL BARRIER STRIP CONNECTION

(AC POWER VERSIONS)

(DC POWER VERSIONS)

T1

1	AC HIGH
2	AC LOW
3	AC GND

4	ANALOG GND
5	SIGNAL LOW
6	SIGNAL HIGH

T1

1	N/C
2	+ DC PWR
3	DC PWR RET

4	ANALOG GND
5	SIGNAL LOW
6	SIGNAL HIGH

ORDERING GUIDE

Make a maximum of one entry per box and separate by commas. An asterisk requires no entry.

Example:

EN45P, 4mA = 0000, 20mA = 19.999, DP2, 9-32Vdc

EN45P **4 1/2 DIGIT PROCESS METER**

INPUT RANGE

Voltage input:

Specify the minimum dc voltage input for a reading of 0000 and the maximum voltage input for the desired full scale counts.
 i.e. 1V = 0000, 5V=18,000.

Current Loop input:

Specify the minimum dc current input for a reading of 0000 and the maximum current input for the desired full scale counts.
 i.e. 4mA= 0000, 20mA=19,999.

DECIMAL POINT
 * User selected
DP1 1.9999, internally jumpered
DP2 19.999, internally jumpered
DP3 199.99, internally jumpered
DP4 1999.9, internally jumpered

POLARITY
 * - sign only
NP no sign

LSD CONTROL
 * 19,999 and -19,999 display
ND 1,999 and -1,999 display

EXCITATION OUTPUT
 * None
E 4.5 to 24Vdc (specify setting)

POWER
 * 115 Vac, 47 to 400 Hz
230Vac 230 Vac, 47 to 400 Hz
9-32Vdc Isolated 9 to 32 Vdc

ACCESSORIES
411-606 Dual 18 pin edge-card connector

HW04 Environmental Cover Kit

MOUNTING AND DIMENSIONS

PANEL CUTOUT (1/8 DIN SIZE)

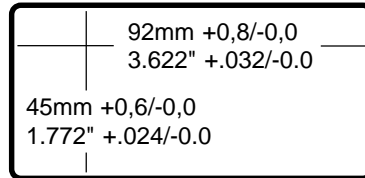

PANEL THICKNESS
Maximum: 6,4mm / .25"
Minimum: 0,6mm / .030"

Max. R
0.4mm/.015"

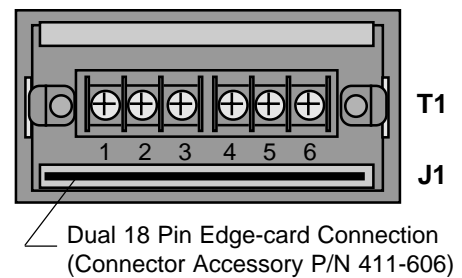
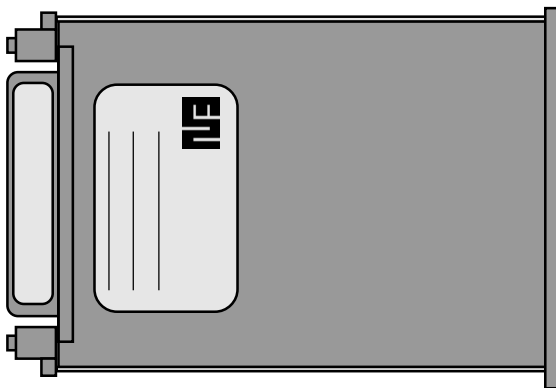

REAR VIEW

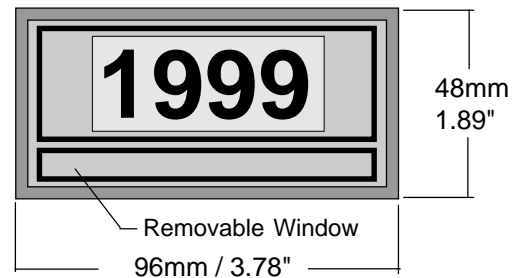
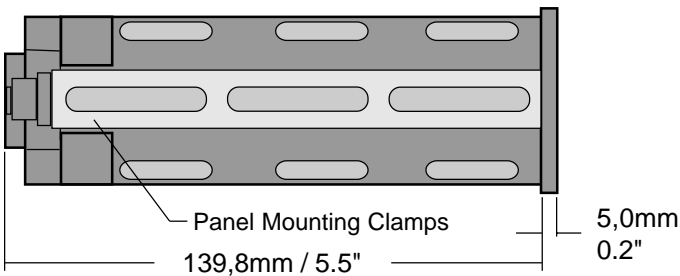

WARRANTY (2 YEARS)

Electro-Numerics Incorporated warrants these products to be free of defects in material and workmanship for two years from date of shipment to original customer. This warranty on materials and workmanship may be considered as unconditional provided that, in the opinion of Electro-Numerics, the equipment has not been mechanically, environmentally or electrically abused.

This warranty is limited, at the option of Electro-Numerics, to repair, replacement, or an appropriate credit adjustment not to exceed the original equipment sales price.

Electro-Numerics assumes no liability in connection with the sales of its products beyond that stated above.

OTHER PRODUCTS

The Electro-Numerics family of **Digital Panel Meters** and **Large Digit Displays** are high quality, accurate, solid state instruments designed for years of trouble free operation. Over 23 years of digital instrumentation experience has resulted in a series of displays recognized in the field as reliable, well designed instruments. From our compact sized NEMA and DIN cased DPM's with 0.6" LED, LCD or PLASMA digits to our Large Digit Displays with 1", 2 1/4" or 4" LED or 4", 6" or 9" tall electromagnetic digits, we cover most applications in process measurement and display. Contact the factory or your local distributor for a catalog on other products.

ELECTRO-NUMERICS, INC.

Call 800-854-8530 or FAX (951) 695-7246 for Applications Assistance

PAGE 10

ELECTRO-NUMERICS DIGITAL PANEL METERS

THE BEST

**QUALITY
PERFORMANCE
RELIABILITY
COST**

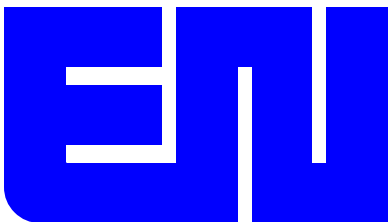

ELECTRO-NUMERICS, INC.

42213 Sarah Way, Temecula CA 92590

Phone: **800-854-8530** or (951) 699-2437 FAX: (951) 695-7246

Web Site: <http://www.electronumerics.com>

Printed in U.S.A.
Art 1070 11/04